



OPERATING MANUAL

J1.5-2.0XNT (K160)

DO NOT REMOVE THIS MANUAL FROM THIS UNIT



LIFT TRUCK MODEL_____

SERIAL NUMBER_____

TRACTION MOTOR_____

SERIAL NUMBER_____

HYDRAULIC PUMP MOTOR_____

SERIAL NUMBER_____

STEERING PUMP MOTOR_____

SERIAL NUMBER_____

MAST LIFT HEIGHT_____

GROUP NUMBER_____

CARRIAGE TYPE_____



GROUP NUMBER_____

DRIVE TIRE SIZE_____

STEERING TIRE SIZE_____

SPECIAL EQUIPMENT OR ATTACHMENTS

© Hyster Company 2017. All Rights Reserved.

HYSTER, , FORTENS, and MONOTROL are Registered Trademarks of Hyster-Yale Group, Inc. DURAMATCH, UNISOURCE, and  are Trademarks in the United States and certain other jurisdictions.



HYSTER

Foreword

Foreword

To OWNERS, USERS, and OPERATORS:

The safe and efficient operation of a lift truck requires skill and alertness on the part of the operator. To develop the skill required, the operator must:

- Receive training in the proper operation of THIS lift truck.
- Understand the capabilities and limitations of the lift truck.
- Become familiar with the construction of the lift truck and see that it is maintained in good condition.
- Read and properly understand the warnings, instructions, and operating procedures in this manual.

In addition, a qualified person, experienced in lift truck operation, must guide a new operator through several driving and load handling operations before the new operator attempts to operate the lift truck alone.

It is the responsibility of the employer to make sure that the operator can see, hear, and has the physical and mental ability to operate the equipment safely.

NOTE: A comprehensive operator training program is available from **Hyster Company**. For further details, contact your dealer for **Hyster** lift trucks.

This **Operating Manual** contains information necessary for the operation and maintenance of a basic fork lift truck. Optional equipment is sometimes installed that can change some operating characteristics described in this manual. Make sure the necessary instructions are available and understood before operating the lift truck.

Some of the components and systems described in this **Operating Manual** will **NOT** be installed on your unit. If you have a question about any item described, contact your dealer for **Hyster** lift trucks.

The following additional information is provided as specified in Machinery Directive 98/37 EEC:

- **Dimensional Details:** Certain information is shown on the lift truck Nameplate. For additional dimensional details on this or any other specific truck, consult your dealer.



Foreword

HYSTER

- **Noise Levels. Note:** The directive legally requires this information. The values have been calculated from the acoustic power levels for lifting and driving only and are only used for comparable value for different trucks. Higher or lower noise emissions can exist during operation of the truck, for example due to type of operation, environmental influences, and additional noise source outside of the truck.

In accordance with standards EN 12053 and EN ISO 4871, the equivalent sound pressure level (L_{paz}) at the operator position is in the range of: 69.0 db(A).

- **Human Vibration (Whole-Body and Hand-Arm Vibration). Note:** The whole-body vibration level is measured according to standard EN 13059 which contains specific test criteria (load, speed, roadway surface, etc.). Work-site vibration levels may vary depending on actual operating and surface conditions.

Whole-body vibration:

- Measured whole body vibration at the operator position, based on standard production truck with full-suspension seat is listed below.

- Declared whole-body vibration emission value is in accordance with EN 12096.

- Measured vibration emission value $a_{w,z} = 0.6 \text{ m/s}^2$

- Uncertainty, $K = 0.2 \text{ m/s}^2$

- Values determined according to EN 13059.

Hand-arm vibration:

- Hand-arm vibration emission value = $<2.5 \text{ m/s}^2$

- **Hazardous Atmosphere:** Before any truck within the European Community can be operated in a Potentially Explosive Atmosphere, it is necessary that the truck is suitably converted for the application. Conversions should only be carried out by a **Hyster** approved supplier. Confirmation of the conversion can be made by referring to the truck Declaration of Conformity which will confirm compliance with European Directive 94/9/ce. If you are in doubt, please contact your **Hyster** dealer for assistance.



CAUTION

Disposal of batteries must meet local environmental regulations.



HYSTER

Foreword

CAUTION

Disposal of lubricants and fluids must meet local environmental regulations.

NOTE: Hyster lift trucks are not intended for use on public roads.

NOTE: The following symbols and words indicate safety information in this manual:

WARNING

Indicates a hazardous situation which, if not avoided, could result in death or serious injury.

CAUTION

Indicates a hazardous situation which, if not avoided, could result in minor or moderate injury and property damage.

On the lift truck, the **WARNING** symbol is on orange background. The **CAUTION** symbol is on yellow background.



Foreword

HYSTER

Atmospheric Conditions

This range of lift trucks is designed to work in the following atmospheric conditions:

Average ambient temperature for continuous duty:	+25°C
Maximum ambient temperature (with reduced performance):	+40°C
Lowest ambient temperature for trucks intended for use in normal indoor conditions:	+5°C
Lowest ambient temperature for trucks intended for use in normal outdoor conditions:	-20°C
Altitude:	Up to 2000m
Relative humidity:	From 30% to 95% (noncondensing)

Lifting

When transporting the truck, should lifting be required, please use the points indicated on the truck by the hook symbols. Traction batteries should be removed and lifted separately by the lifting eyes on the battery box.



HYSTER

Foreword

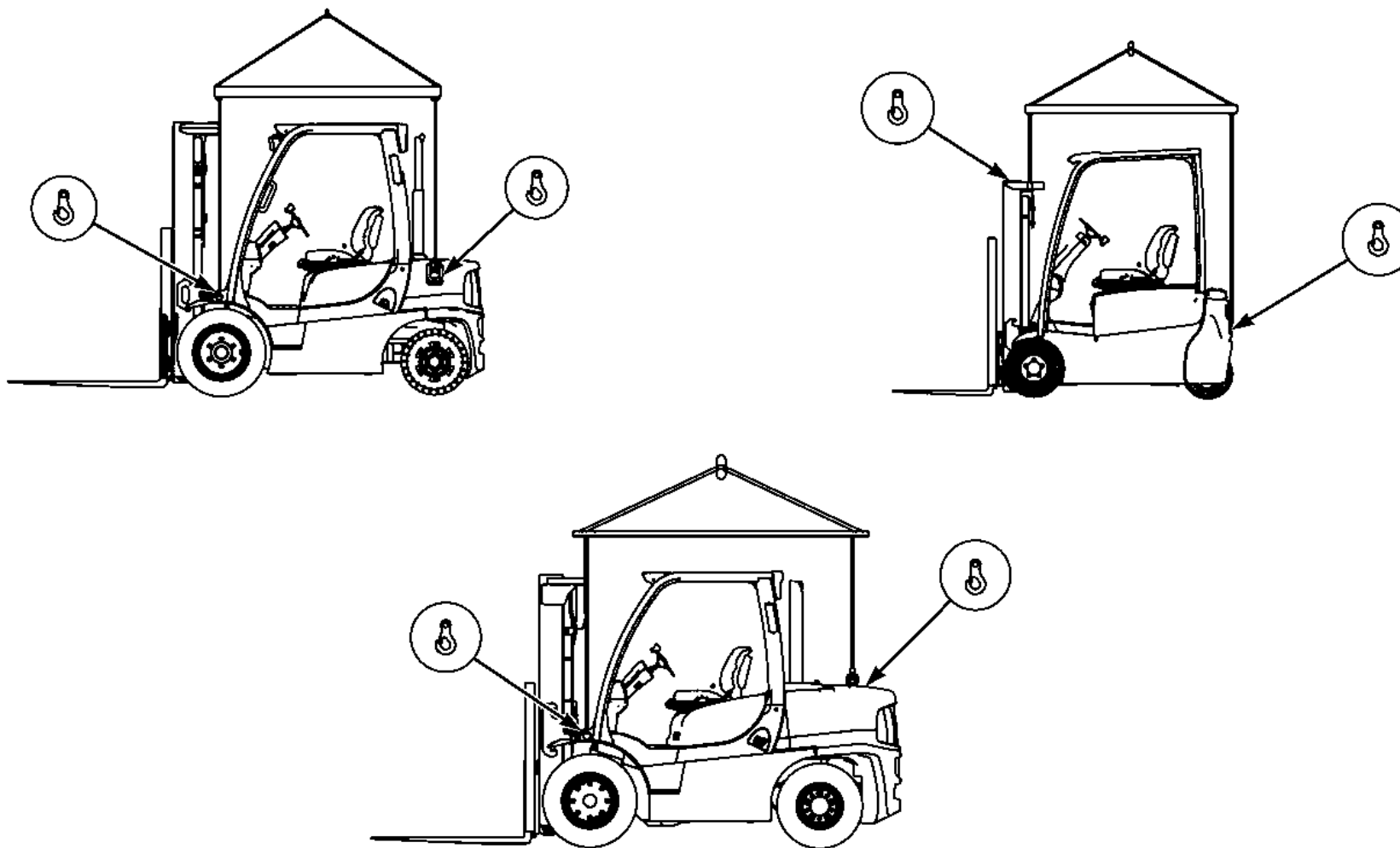

B0191677

Lifting points applicable to lift trucks shipped to Russia.



Foreword

HYSTER

HYSTER



EC DECLARATION OF CONFORMITY

WE
HYSTER EUROPE
CENTENNIAL HOUSE
BUILDING 4.5
FRIMLEY BUSINESS PARK
FRIMLEY, SURRY GU16 7SG
UNITED KINGDOM

DECLARE UNDER OUR SOLE RESPONSIBILITY THAT THE MACHINE

CATEGORY: FORKLIFT BATTERY POWERED

TYPE _____

SERIAL NUMBER(S) _____

YEAR OF CONSTRUCTION _____

IS IN CONFORMITY WITH THE MACHINERY DIRECTIVE 2006/42/EC. COMPLIANCE WITH THIS DIRECTIVE IS ESTABLISHED BY MEETING THE TECHNICAL REQUIREMENTS OF THE RELEVANT STANDARDS, INCLUDING EN ISO 3691-1

OTHER APPLICABLE DIRECTIVES:
2014/30/EU - EMC EMISSIONS

TECHNICAL FILE CONTROLLED BY THE ENGINEERING MANAGER, HYSTER-YALE UK LIMITED, CRAIGAVON, NORTHERN IRELAND

NAME _____
POSITION PLANT MANAGER
(BLOCK LETTERS)

SIGNATURE _____
DATE _____



HYSTER

Contents

		Contents	
Foreword	1	Capacity (Weight and Load Center)	88
TO OWNERS, USERS, AND OPERATORS:	1	Impact Sensor	89
ATMOSPHERIC CONDITIONS	4	CABIN HEATER	90
LIFTING	4	INSPECTION BEFORE OPERATION	93
Warning	11	Checks With the Key or Keyless Switch OFF	94
Model Description	14	Operator Passwords	94
GENERAL	15	Operator Checklist	96
OPERATOR PROTECTION EQUIPMENT	22	Mounting and Dismounting	99
NAMEPLATE	23	Start-Up Procedure - SRO Circuit	99
SAFETY LABELS	24	Lift Trucks with Software Versions Less than 4.32 .	99
OPERATOR CONTROLS	28	Lift Trucks with Software Versions 4.32 and	
Display Panel Features	62	Greater	100
DISPLAY PANEL	62	Lift Truck Interlocks	101
DISPLAY PANEL KEYS	63	Checks With the Key or Keyless Switch ON	110
DISPLAY PANEL - LCD SCREEN AND WARNING		Load Weighing Sensor	111
AND INDICATOR LIGHTS	71	Set Load Weight to Zero	111
NORMAL SEQUENCE OF OPERATION - DISPLAY		OPERATING TECHNIQUES	113
PANEL	83	Basic Operating Procedures	114
NORMAL SEQUENCE OF OPERATION - DISPLAY		Driving and Direction Changes	119
PANEL WITH OPTIONS	84	Steering (Turning)	120
Operating Procedures	86	Synchronized Steering Control	122
GENERAL	86	E-Steering Control	122
Know Your Lift Truck	86	Auto Power Off	123
Stability and Center of Gravity	87	Standard Operator Presence System	123



Contents

HYSTER

Lift Trucks with Software Versions Less than 4.32 .	124	How to Raise the Drive Tires	150
Lift Trucks with Software Versions 4.32 and Greater	124	How to Raise the Steer Tire	150
Optional Operator Presence System	124	HOW TO CLEAN A LIFT TRUCK	152
Lift Trucks with Software Versions 4.32 and Greater	125	Maintenance Schedule	152
Automatic Parking Brake	126	Maintenance Procedures Every Shift	168
Load Handling - General	128	HOW TO MAKE CHECKS WITH THE KEY OR KEYLESS SWITCH OFF	168
Lifting, Lowering, and Tilting	129	Wheels and Tires	168
How to Engage and Disengage a Load	132	Safety Labels	169
Load Handling, Traveling	135	Frame and Covers	169
Load Handling, Emergency Load Lowering	138	Forks, General	171
Manual Main Control Valve	138	Forks, Remove	171
E-Hydraulic Main Control Valve	140	Forks, Inspect	174
HIGHWAY TRUCK, RAILROAD CARS, AND DOCKS	142	Forks, Install	176
ATTACHMENTS	143	Forks, Adjust	177
STOPPING	144	Inspection of Mast, Carriage, Header Hoses, Lift Chains, and Attachments	177
PARKING	144	Hydraulic Oil Level and Leaks	180
Maintenance	145	Operator Restraint System	180
GENERAL	145	Emergency Locking Retractor (ELR)	182
SERIAL NUMBER DATA	146	Battery Restraint System	184
HOW TO MOVE A DISABLED LIFT TRUCK	147	Lift Trucks Manufactured Before March, 2015	190
How to Tow the Lift Truck	148	Lift Trucks Manufactured After February, 2015	190
HOW TO PUT A LIFT TRUCK ON BLOCKS	150	Steering Column Adjustments	194
		Tilt Adjust Feature	196



HYSTER

Contents

Tilt Memory Feature	196	Optional Removable Battery Tray/Stand, Battery Remove	219
Telescopic Feature	196	Optional Removable Battery Tray/Stand, Battery Install	222
Battery Check	196	Battery Exchange Stacker Option	222
HOW TO MAKE CHECKS WITH THE KEY OR KEYLESS SWITCH ON	197	Battery Stand Set-up	225
Control Levers and Pedals	197	Optional Battery Roller Extraction	226
Direction and Speed Control Pedals	198	BATTERY SPECIFICATIONS	227
Electrical Components	198	TIRES AND WHEELS	229
Steering System	199	Snap-On Solid Rubber Tires	229
Hydraulic System	200	Remove the Snap-On Solid Tire From the Wheel	231
Service Brakes	201	Install the Snap-On Solid Tire on the Wheel	231
Automatic Parking Brake	201	Tire Sizes	233
Operator Presence System	201	Install Snap-On Solid Tire and Wheel on Lift Truck .	233
Oil Leaks	202	HOW TO PUT AN ELECTRIC SIT DOWN RIDER TRUCK IN STORAGE	233
HOW TO CHARGE THE BATTERY	202	HOW TO PUT BATTERIES IN STORAGE	235
RAPID CHARGE	205	HOW TO PUT A LIFT TRUCK BACK INTO SERVICE	235
HOW TO CHANGE BATTERIES	206	HOW TO MOVE A LIFT TRUCK ON A TRANSPORT	236
General	206	Loading	236
Remove the Battery	206	Unloading	237
Install the Battery	208	PREPARATION FOR USE	237
Optional Side Removal of Battery - Lift Trucks Manufactured Before March, 2015	211	Preparation After Transport	237
Optional Side Removal of Battery - Lift Trucks Manufactured After February, 2015	213		



Contents

HYSTER

CHANGES TO THE OVERHEAD GUARD 238

Maintenance Register 239



HYSTER

Warning

WARNING

**FAILURE TO FOLLOW THESE INSTRUCTIONS CAN CAUSE SERIOUS INJURY OR DEATH!
AUTHORIZED, TRAINED OPERATOR ONLY!**

The following **WARNING** is a label and must be on the lift truck.

KNOW THE EQUIPMENT:

- KNOW operating, inspection, and maintenance instructions in **Operating Manual**.
- **DO NOT** operate or repair truck unless trained and authorized.
- INSPECT truck before use.
- **DO NOT** operate if truck needs repair. Tag truck and remove key. Repair truck before use. Always use **Hyster Approved** parts when making repairs. Replacement parts must meet or exceed the specifications of the original equipment manufacturer.
- USE attachments for intended purpose only.
- MAKE SURE truck is equipped with overhead guard and load backrest adequate for the load.

LOOK WHERE YOU ARE GOING:

- IF YOU CAN'T SEE, DON'T GO.
- TRAVEL in reverse if load blocks forward vision.
- MAKE SURE tail swing area is clear before turning.
- SOUND horn at intersections or whenever vision is blocked.
- WATCH clearances, especially overhead.

KNOW YOUR LOADS:

- HANDLE only stable loads within specified weight and load center. See Nameplate on this truck.
- DO NOT handle loose loads higher than load backrest.
- SPACE forks as far apart as load allows and center load between forks. Keep load against load backrest.



Warning

HYSTER

WARNING

**FAILURE TO FOLLOW THESE INSTRUCTIONS CAN CAUSE SERIOUS INJURY OR DEATH!
AUTHORIZED, TRAINED OPERATOR ONLY!**

KNOW THE AREA:

- CHECK dockboard width, capacity, and security.
- NEVER enter a trailer or railroad car unless the wheels are blocked.
- WATCH floor strength.
- FILL fuel tank or charge battery only in designated area.
- AVOID sparks or open flame.
- Provide ventilation.
- TURN OFF engine when fueling.
- DO NOT start truck if fuel is leaking.
- KEEP vent caps clear when charging battery.
- DISCONNECT battery during servicing.

USE COMMON SENSE:

- NEVER transport people on any part of the truck.

- DO NOT use truck to lift people unless there is no other practical option. Then, use only a securely attached special work platform.
- ALLOW NO ONE under or near lift mechanism or load.
- DO NOT move truck if anyone is between truck and stationary object.
- OPERATE truck only from operator's seat.
- KEEP arms, legs, and head inside operator's compartment.
- OBEY traffic rules. Yield right-of-way to pedestrians.
- BE in complete control at all times.
- BEFORE DISMOUNTING, neutralize travel control, lower carriage, and set brake.
- WHEN PARKING, also shut off power, close LPG fuel valve, block wheels on inclines.



HYSTER

Warning

WARNING

**FAILURE TO FOLLOW THESE INSTRUCTIONS CAN CAUSE SERIOUS INJURY OR DEATH!
AUTHORIZED, TRAINED OPERATOR ONLY!**

PROTECT YOURSELF, FASTEN YOUR SEAT BELT!

- AVOID bumps, holes, loose materials, and slippery areas.
- AVOID sudden movements. Operate all controls smoothly.
- NEVER turn on, or angle across an incline. Travel slowly.
- TRAVEL on inclines with load uphill or unloaded with mast downhill.
- TILT mast slowly and smoothly.

- LIFT or LOWER with mast vertical or tilted slightly back. Use minimum tilt when stacking elevated loads.
- TRAVEL with carriage as low as possible and tilted back.
- SLOW DOWN before turning, especially without load.

FAILURE TO FOLLOW THESE INSTRUCTIONS CAN CAUSE THE LIFT TRUCK TO TIP OVER!

DO NOT JUMP off if the truck tips! HOLD steering wheel firmly. BRACE your feet. LEAN FORWARD and AWAY from point of impact.

Model Description

HYSTER

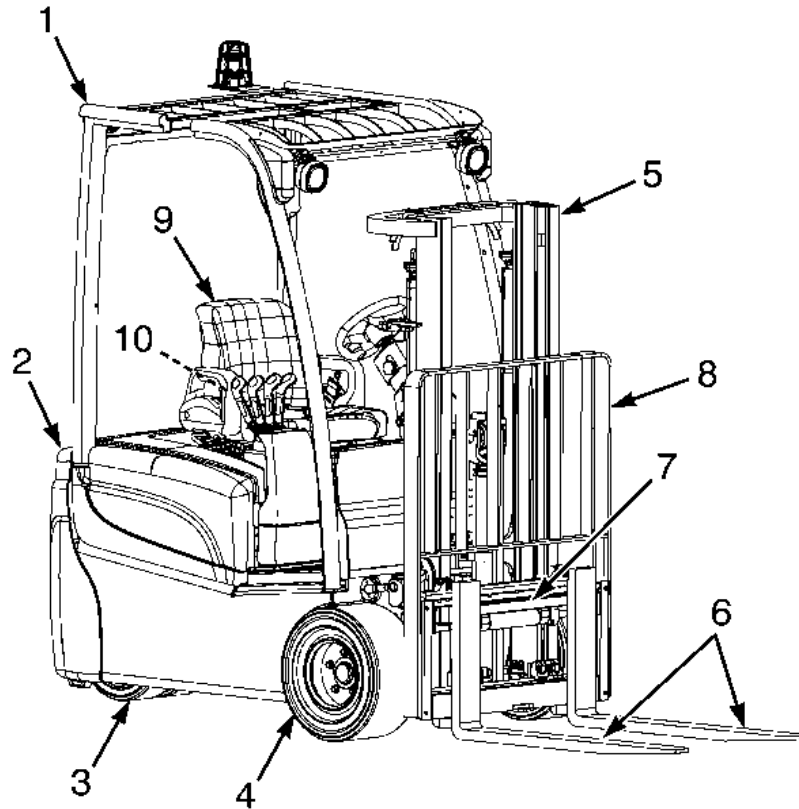

1. OVERHEAD GUARD
2. COUNTERWEIGHT
3. STEER WHEELS
4. DRIVE WHEELS
5. MAST
6. FORKS
7. CARRIAGE
8. LOAD BACKREST EXTENSION
9. OPERATOR SEAT
10. SEAT BELT AND HIP RESTRAINT

BO190527

Figure 1. Major Components of the Lift Truck



HYSTER

Model Description

Model Description

General

This series of electric lift trucks is available in the following models: (see **Figure 1**).

J1.5XNT, J1.6XNT, J1.8XNT, and J2.0XNT (K160)

The lift trucks covered in this **Operating Manual** are equipped with solid rubber tires that look like pneumatic tires. See **Tires and Wheels** in the **Maintenance Section** for a description of these tires.

The operation of the lift truck is the same for all models. A battery supplies power for the traction motors, hydraulic pump motor, control panel, and display panel.

The lift trucks covered in this **Operating Manual** are manufactured with three motors: two traction motors and a hydraulic pump motor. See **Figure 2** and **Figure 3**.

The motors use AC motor and control technology. The traction motors are mounted between the left and right

transmissions on the drive axle. The hydraulic pump motor is mounted behind the driver and in front of the counterweight. See **Figure 2** and **Figure 3**.

In addition to dual, hydraulically-operated, wet disc service brakes and electrically-operated disc parking brake, the lift trucks covered in this **Operating Manual** are equipped with electric braking (plugging) and an auto brake feature. When the lift truck is traveling in one direction and the direction control switch or MONOTROL® pedal is changed to the opposite direction, the plugging function is energized.

Auto regenerative braking allows the user to set the distance the truck will coast when the direction control switch is returned to the **NEUTRAL** position or when the MONOTROL® or accelerator pedal is released.

Model Description

HYSTER

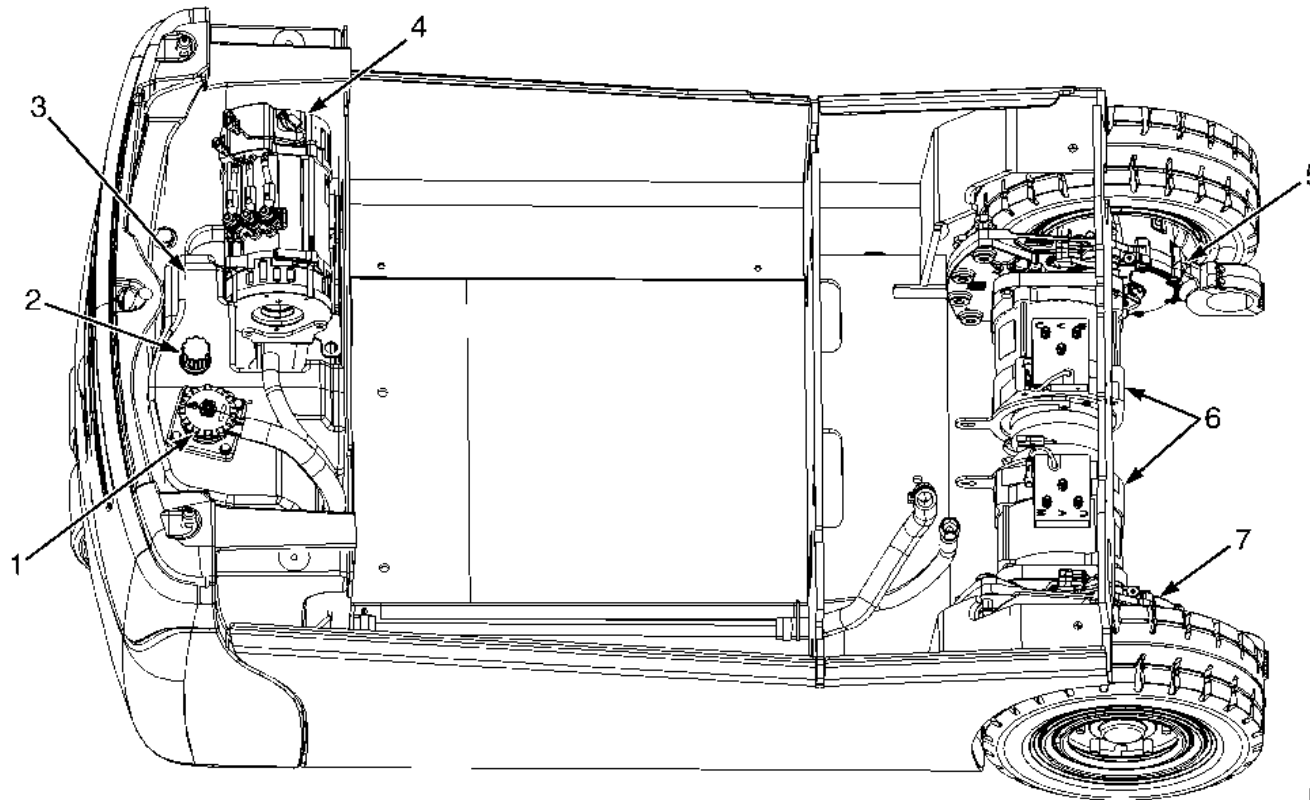

1. HYDRAULIC FILTER
2. HYDRAULIC BREATHER CAP/
DIPSTICK
3. HYDRAULIC TANK
4. HYDRAULIC PUMP MOTOR
5. LEFT TRANSMISSION
6. TRACTION MOTORS
7. RIGHT TRANSMISSION

BO190405

Figure 2. Motor Locations, Lift Trucks Manufactured Before March, 2015

HYSTER

Model Description

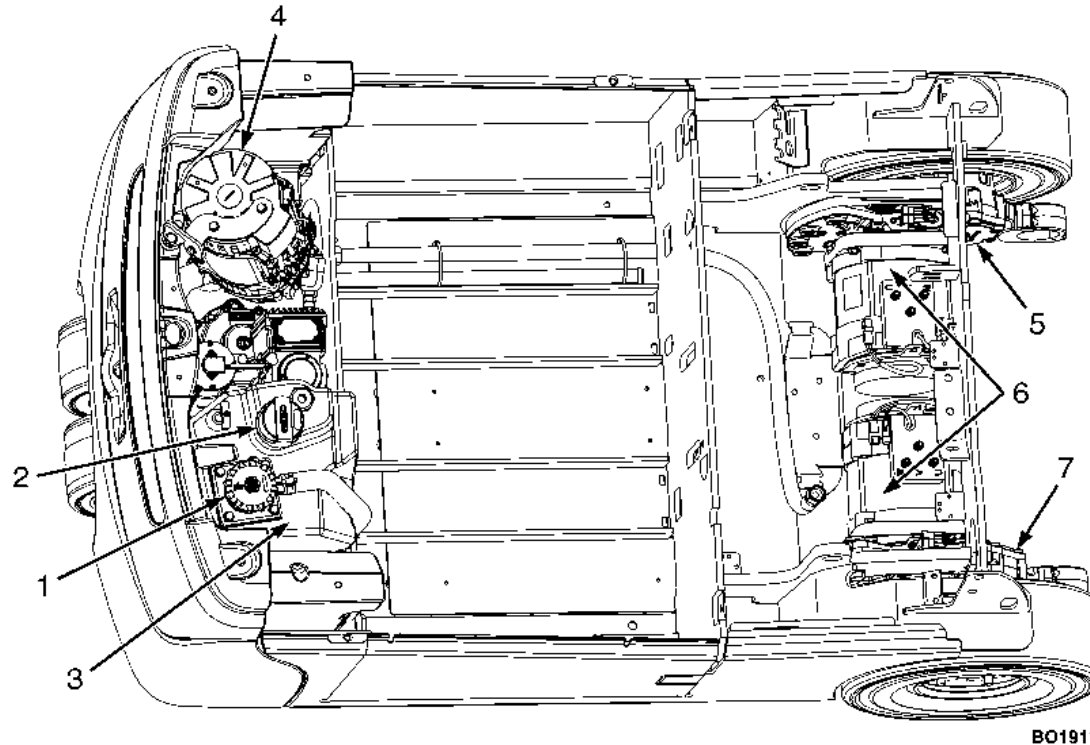

BO191150

1. HYDRAULIC FILTER
2. HYDRAULIC BREATHER CAP/
DIPSTICK
3. HYDRAULIC TANK
4. HYDRAULIC PUMP MOTOR
5. LEFT TRANSMISSION
6. TRACTION MOTORS
7. RIGHT TRANSMISSION

Figure 3. Motor Locations, Lift Trucks Manufactured After February, 2015



Model Description

HYSTER

A brake pedal actuates the hydraulic service brakes at the drive wheels.

The lift trucks covered in this **Operating Manual** can be equipped with either standard manual hydraulic levers, or Electro-Hydraulic (E-Hydraulic) mini-levers.

Forward or reverse movements can be controlled by either a MONOTROL® pedal or a direction control switch. If the lift truck is equipped with E-Hydraulic mini-levers, the direction control switch is located on the left side of the armrest, in front of the horn button. If the lift truck is equipped with manual hydraulic levers, the direction control switch is located on the left side of the first lever. See **Figure 4**.

All lift trucks are equipped with a Battery Discharge Indicator (BDI) and an hourmeter. The bar graph type of BDI shows the state of charge of the battery. These lift trucks have Liquid Crystal Display (LCD) screen. The LCD screen shows the battery bar graph and provides other service information. Hourmeter operating time(s) are also shown on the LCD screen.

See **Display Panel Features** in this section for a more detailed description of how these display panels operate.

HYSTER

Model Description

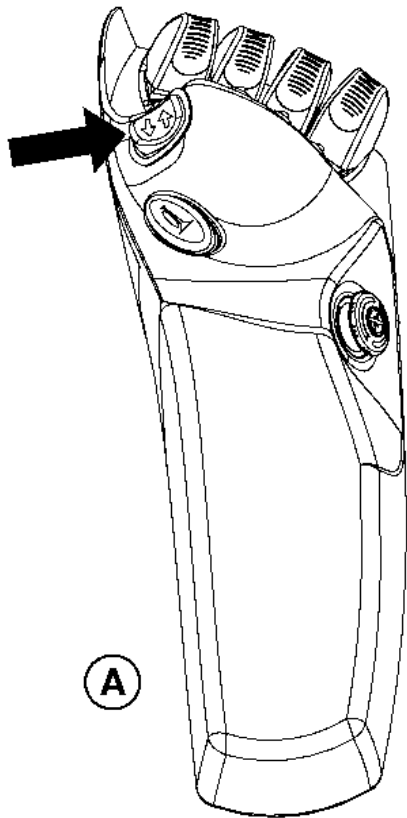

A. E-HYDRAULIC CONTROL MINI-LEVERS

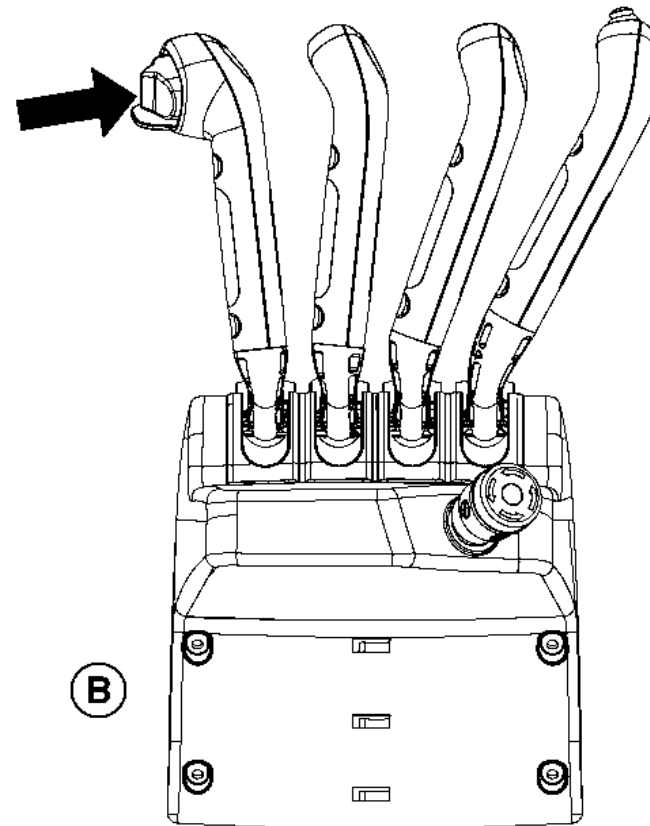

B. MANUAL HYDRAULIC CONTROL LEVERS

Figure 4. Direction Control Switch

BO190430



Model Description

HYSTER

The electric lift trucks described in this manual are equipped with a full suspension swivel seat. See **Figure 5**.

The full suspension swivel seat allows the operator to move the seat to the left and to the right. The seat can be moved 5 degrees to the left and 12 degrees to the right.

The full suspension swivel seat allows the operator to better see where they are going when driving the lift truck in reverse.

HYSTER

Model Description

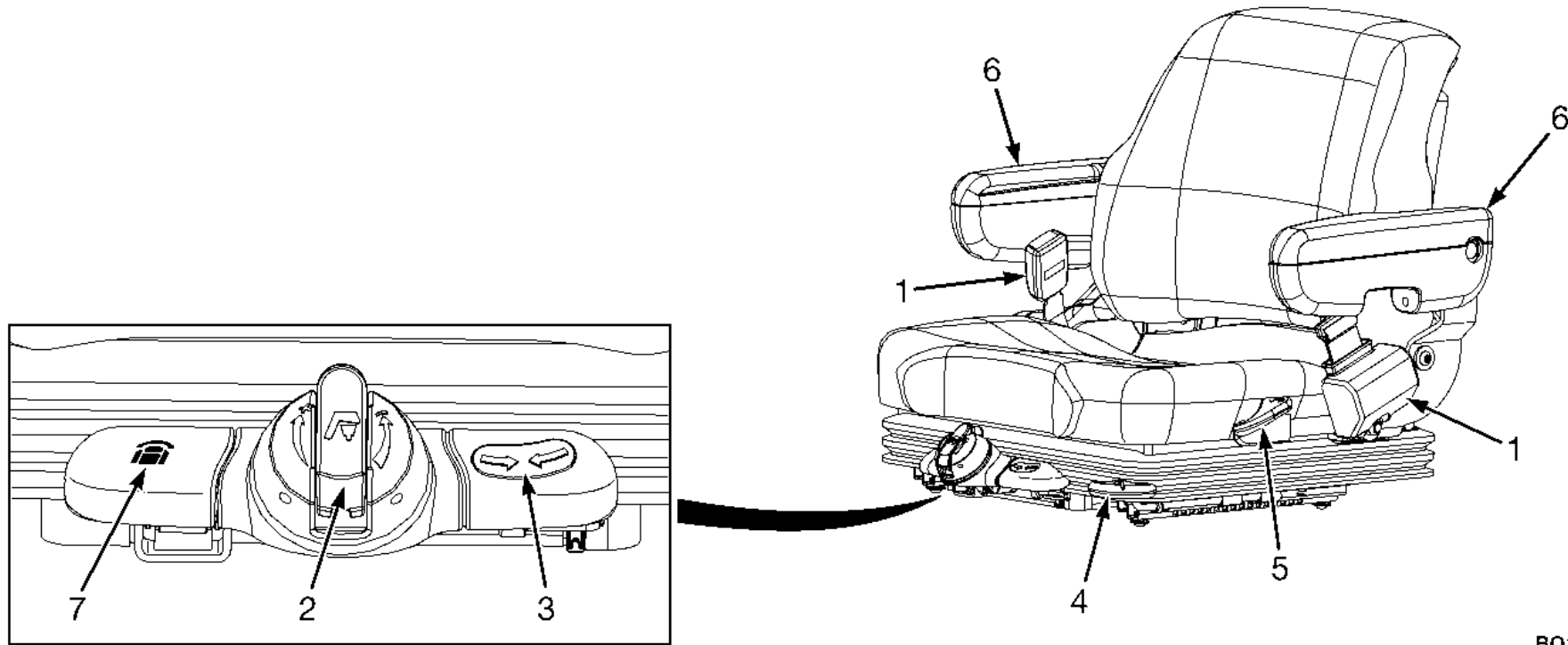

BO190622

1. SEAT BELT
2. WEIGHT ADJUSTMENT KNOB
3. RIDE POSITION INDICATOR
4. FORWARD/BACKWARD ADJUSTMENT LEVER

5. BACKREST ANGLE ADJUSTMENT LEVER
6. ARMREST
7. SWIVEL LATCH RELEASE LEVER

Figure 5. Seat Components



Model Description

HYSTER

Operator Protection Equipment

The OVERHEAD GUARD is intended to offer reasonable protection to the operator from falling objects, but cannot protect against every possible impact. Therefore, it must not be considered a substitute for good judgment and care when handling loads. Do not remove the overhead guard. See **Figure 1**.

The BATTERY RESTRAINT SYSTEM is designed to hold the battery within the battery compartment if a tipover occurs. The battery restraint system contains a front spacer plate, a battery plate, front and rear bulkheads, and the left and right frame plates. The lift truck can be equipped with optional side rollers or fork pockets on the battery plate to help in removing the battery from the truck.

The hood and hood latch mechanism also help keep the battery within the battery compartment if a tipover occurs. The hood can be raised for access to the battery. A gas spring helps raise and hold the hood in the up position.

The battery restraint system must function so that the operator restraint system can operate correctly. Operation of the battery restraint system requires that the maximum movement allowed for the battery is 13 mm (0.5 in.) in any horizontal direction. This will reduce the risk of operator

injury in a truck tipover. An adjustable front battery spacer plate prevents the front-to-back movement of the battery. Batteries for this series of lift trucks must all have the same length dimension to just fit the battery compartment width. For correct battery sizes, see the **Battery Specifications** in the back of this manual.

NOTE: The seat belt can be either black or red.

This lift truck is equipped with one of the three seat belt configurations.

- Seat belt with no operation interlock.
- Seat belt with operation interlock. Seat belt must be fastened for lift truck to start or to travel.
- Seat belt with sequencing interlock. Operator must be in the seat, then the seat belt fastened before lift truck will operate. This seat belt is used with the Optional Operator Presence System.

The SEAT BELT and ARMREST provide additional means to help the operator keep the head and torso substantially within the confines of the truck frame and operator compartment if a tipover occurs. This restraint system is intended to reduce the risk of the head and torso being trapped between the lift truck and the ground, but it cannot protect



HYSTER

Model Description

the operator against all possible injury in a tipover. The armrest will help the operator resist side movement if the seat belt is not fastened. It is not a substitute for the seat belt. Always fasten the seat belt.

This lift truck may be equipped with an optional operator presence system which will not allow the truck to travel unless the seat belt is fastened. When equipped, a seat belt interlock includes sequencing/logic for the seat pressure switch and seat belt switch. The weight of the operator must be detected prior to the seat belt switch being engaged to enable operations.

The LOAD BACKREST EXTENSION is installed to keep loose parts of the load from falling back toward the operator. It must be high enough, with openings small enough to prevent the parts of the load from falling backward. If a load backrest extension that is different from the one installed on your truck is required, contact your dealer for **Hyster** lift trucks.

Nameplate

WARNING

Any change to the lift truck, the tires, or its equipment can change the lifting capacity. If the Nameplate does

not show the maximum capacity, or if the lift truck equipment, including the battery for electric trucks, does not match that shown on the Nameplate, the lift truck must not be operated.

The capacity is the maximum load that the lift truck can handle for the load condition shown on the Nameplate. The capacity is specified in kilograms (kg) and pounds (lb).

The maximum capacity for the lift truck, at full load height, must be shown on the Nameplate. Special capacities with the load height reduced or with optional load centers, may also be shown on the Nameplate.

NOTE: The image in **Figure 6** is a sample only. Reference the actual nameplate installed on the truck for actual truck specifications.

The lift truck serial number code is on the Nameplate. The serial number code is also stamped on the left side of the front face of the cowl.

When a lift truck is shipped incomplete from the factory, the Nameplate is covered by the labels shown in **Figure 6**. If your lift truck has this type of label, do not operate the lift truck. Contact your dealer for **Hyster** lift trucks to obtain a complete Nameplate.

Model Description

HYSTER

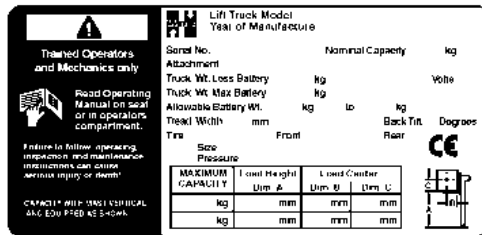

(A)

Safety Labels

Safety labels are installed on the lift truck to provide information about possible hazards. It is important that all safety labels are installed on the lift truck and can be read. See Figure 7.

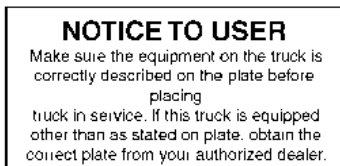

(B)

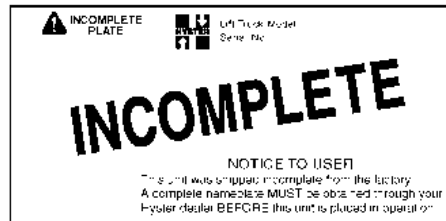

(C)

HO191250

- A. NAMEPLATE
- B. NOTICE LABEL
- C. INCOMPLETE LABEL

Figure 6. Nameplate and Label

HYSTER

Model Description

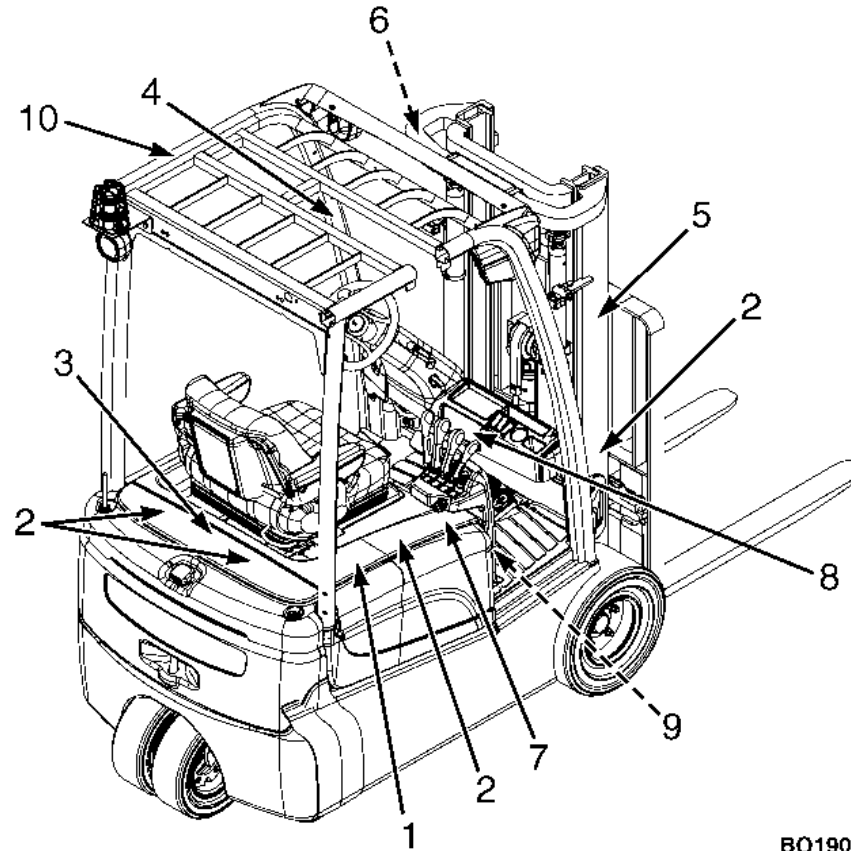

BO190565

Figure 7. Warning Labels (Sheet 1 of 3)



Model Description

HYSTER



WARNING

FAILURE to follow these instructions can cause **SERIOUS INJURY** or **DEATH**.
AUTHORIZED, TRAINED OPERATOR ONLY!

USE COMMON SENSE:

- NEVER transport people on any part of the truck.
- OBEY traffic rules. Yield right-of-way to pedestrians.
- BE in complete control at all times.
- ALLOW NO ONE under or near lift mechanism or load.
- OPERATE truck only from operator's seat.
- KEEP arms, legs, and head inside operator's compartment.
- DO NOT move truck if anyone is between truck and stationary object.
- DO NOT use truck to lift people unless no other practical option. Then use only securely attached special work platform. Follow instructions in manual.
- BEFORE DISMOUNTING, neutralize travel control, lower carriage, set brake.
- WHEN PARKING, also shut off power, close LPG fuel valve, block wheels on inclines.

KNOW THE AREA:

- NEVER enter a trailer or railroad car unless its wheels are blocked.
- CONFIRM floor strength.
- FILL fuel tank or charge battery only in designated area.
- TURN OFF engine when fueling.
- AVOID sparks or open flame. Provide ventilation.
- DO NOT start if fuel is leaking.
- KEEP vent caps clear when charging battery.
- DISCONNECT battery during servicing.
- CHECK dockboard width, capacity and security.

PROTECT YOURSELF:

- AVOID bumps, holes, loose materials and slippery areas.
- AVOID sudden movements. Operate all controls smoothly.
- NEVER turn on or angle across an incline. Travel slowly.
- TRAVEL on inclines with load uphill or unloaded with mast downhill.
- TILT mast slowly and smoothly. LIFT or LOWER with mast vertical or tilted slightly back. Use minimum tilt when stacking elevated loads.
- TRAVEL with carriage as low as possible and tilted back.
- SLOW DOWN before turning-especially without load.

FAILURE to follow these instructions can cause the truck to tip over!
DO NOT JUMP off if the truck tips! HOLD steering wheel firmly.
BRACE your feet. LEAN FORWARD and AWAY from point of impact.

KNOW THE EQUIPMENT:

- KNOW operating, inspection and maintenance instructions and warnings in MANUAL.
- DO NOT operate or repair truck unless trained and authorized.
- INSPECT truck before use. Do not operate if truck needs repair. Tag truck and remove key. Repair truck before use.
- USE attachments for intended purpose only.
- MAKE SURE truck is equipped with overhead guard and load backrest adequate for the load.



LOOK WHERE YOU ARE GOING:

- IF YOU CAN'T SEE, DON'T GO!
- TRAVEL in reverse if load blocks forward vision.
- MAKE sure tailswing area is clear before turning.
- SOUND horn at intersections or where vision is blocked.
- WATCH clearances, especially overhead.

KNOW YOUR LOADS:

- HANDLE only stable loads within specified weight and load center. See plate on this truck.
- DO NOT handle loose loads higher than load backrest.
- SPACE forks as far apart as load allows and center load between forks. Keep load against load backrest.

← 1

HO190239

Figure 7. Warning Labels (Sheet 2 of 3)

HYSTER

Model Description

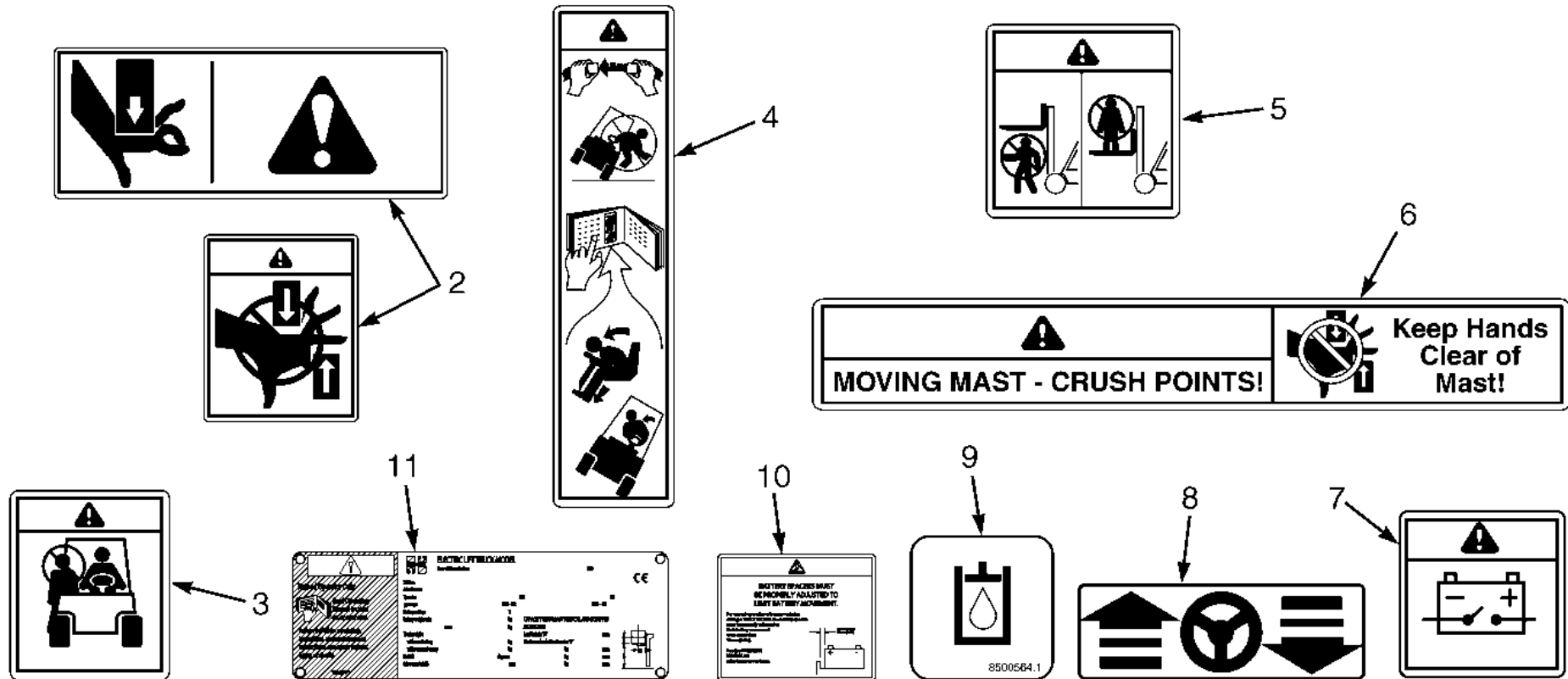

BO190513

Figure 7. Warning Labels (Sheet 3 of 3)



Model Description

HYSTER

Legend for Figure 7

- | | |
|---|---|
| <ol style="list-style-type: none"> 1. OPERATOR WARNING 2. PINCH POINTS 3. NO RIDERS 4. TIPOVER WARNING UNITS WITH SEAT BELTS 5. MAST WARNING | <ol style="list-style-type: none"> 6. MAST WARNING 7. BATTERY DISCONNECT 8. NAMEPLATE 9. BATTERY SPACER 10. OVERHEAD GUARD IMPACT RATING |
|---|---|

Operator Controls

(See Figure 8, Figure 9, Figure 10, and Table 1)

WARNING

If any of the levers or pedals do not operate as described in the following tables, report the problem immedi-

ately. Injury to personnel can occur if the levers or pedals do not operate as described in the following table. **DO NOT** operate the lift truck until the problem is corrected.

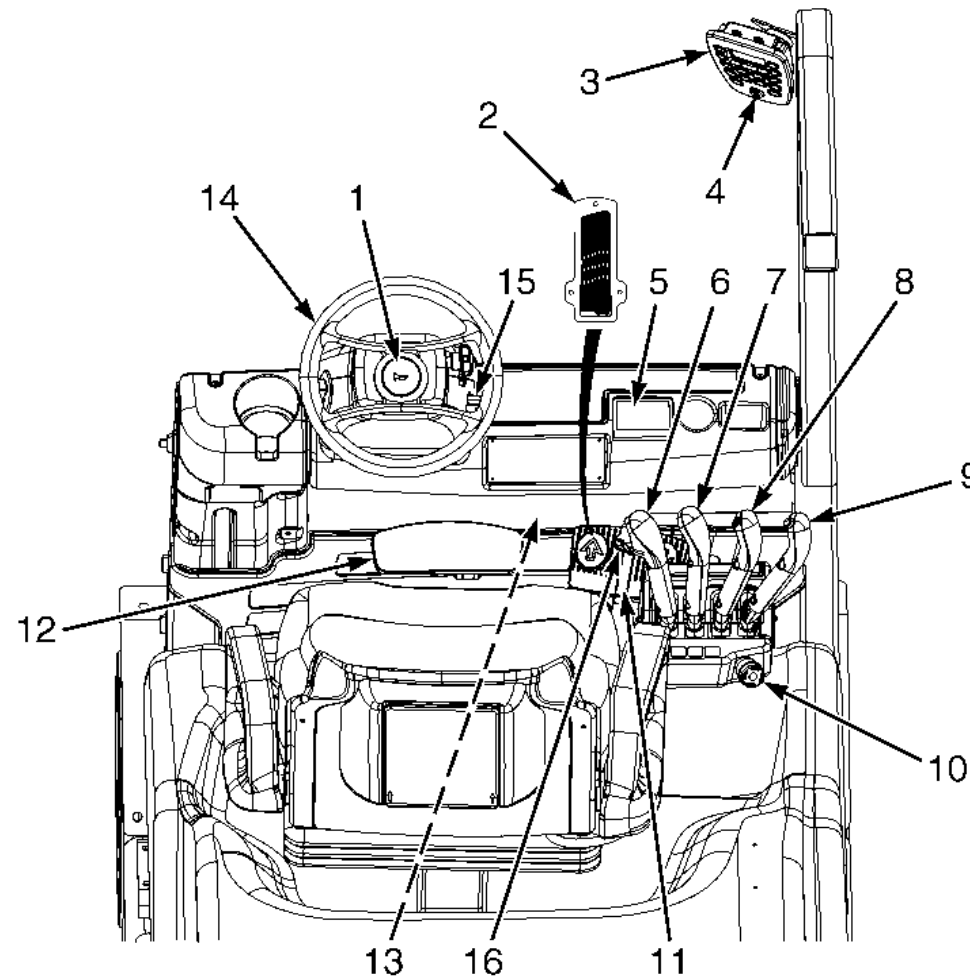

BO210015

Figure 8. Operator Controls - Manual Hydraulic Controls

Model Description

HYSTER

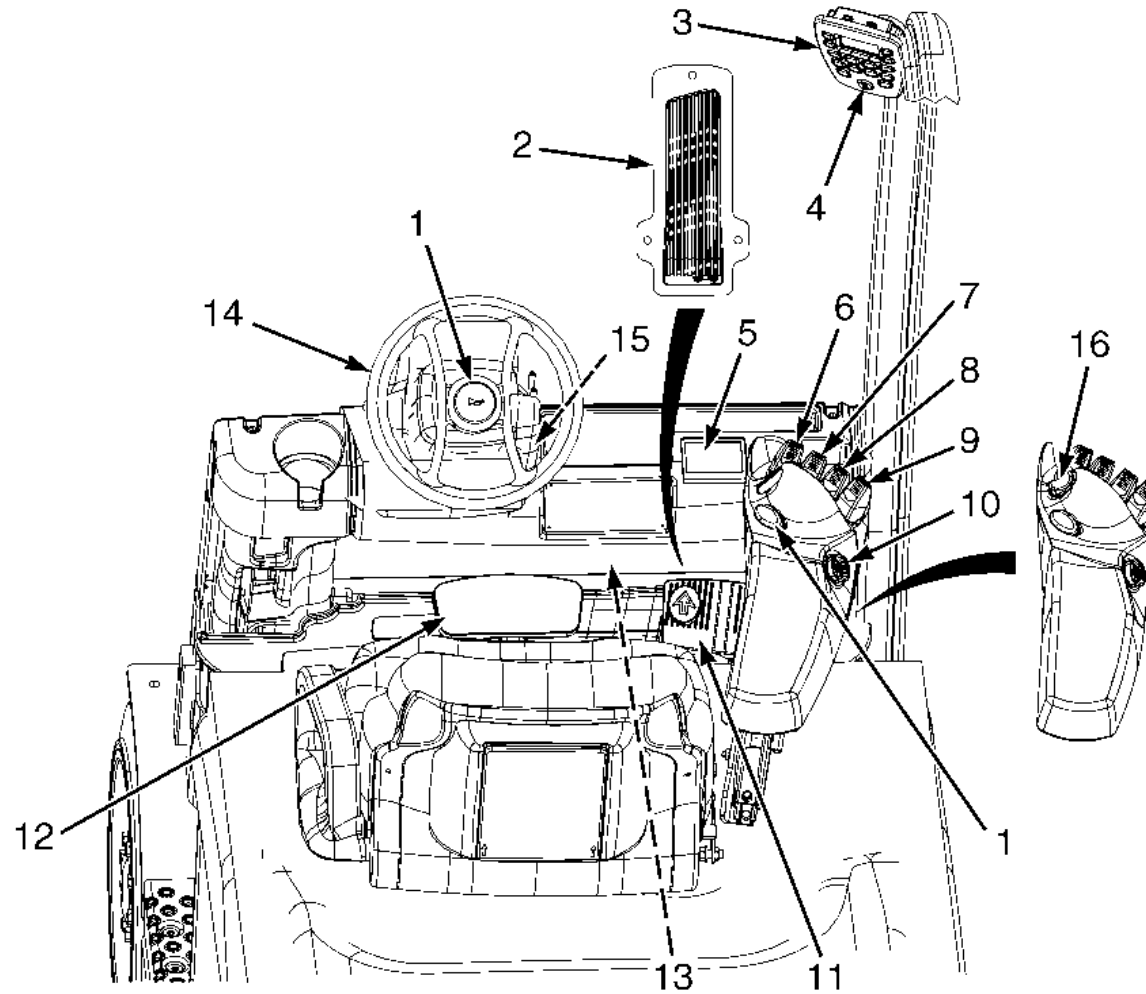

BO190514

Figure 9. Operator Controls - Electro-Hydraulic Controls

HYSTER

Model Description

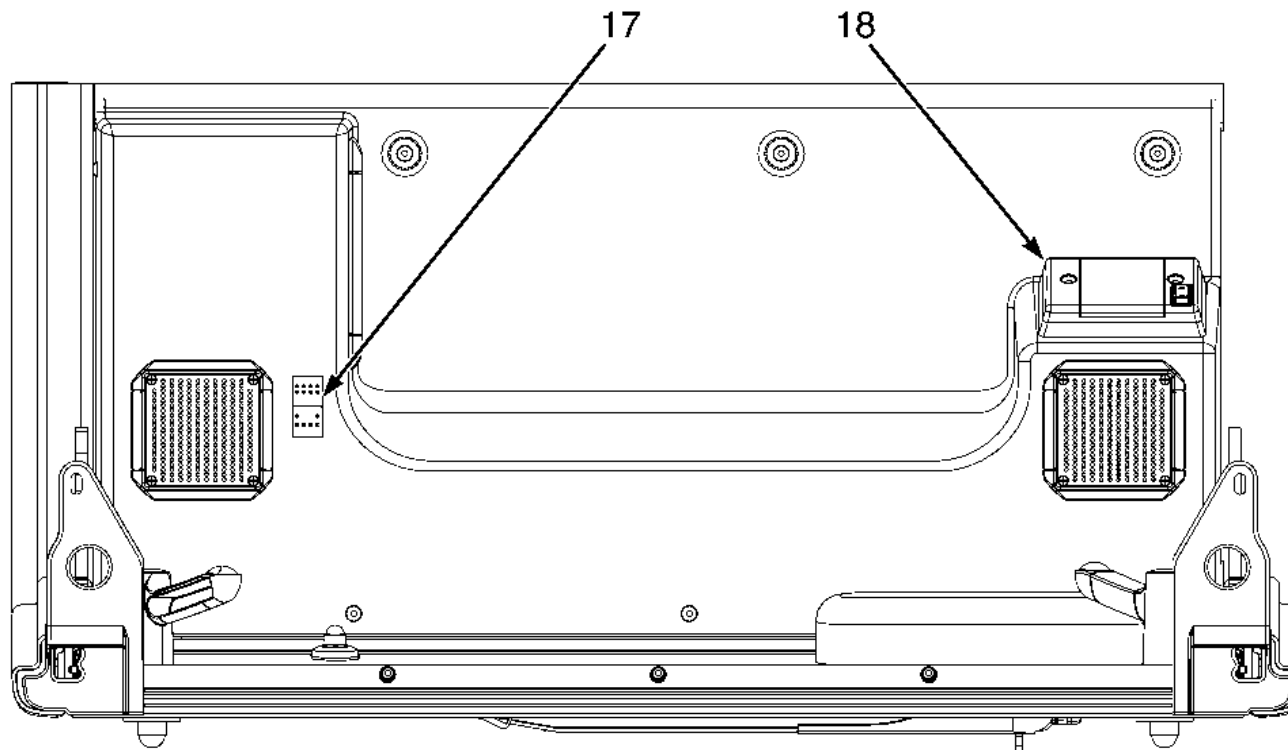

BO190829

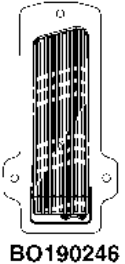

Figure 10. Operator Controls - Overhead



Model Description

HYSTER

Table 1. Operator Controls (See Figure 8 and Figure 9)

Item No.	Item	Function
1	Horn Button 	Push the horn button to warn pedestrians and others when approaching intersections and other blind areas. If lift truck is equipped with E-Hydraulic controls, there is another horn button located on the armrest. There may also be a handle on the rear right side overhead guard leg that has a horn button on it. See the end of Table 1 for more information.
2	Accelerator Pedal 	The accelerator pedal is used with the direction control switch described in this table and when the lift truck is not equipped with a MON-OTROL® pedal. Push down on the accelerator pedal to increase the speed of the lift truck
3	Display Panel 	See Display Panel Features in this section, and Figure 11 , Figure 12 , Table 2 , and Table 3 for a detailed description.

HYSTER

Model Description

Table 1. Operator Controls (See Figure 8 and Figure 9) (Continued)

Item No.	Item	Function
4	<p>Key Switch and Keyless Switch</p> <p>BO190530</p>	<p>⚠ WARNING</p> <p>The ignition switch is a reed switch which uses an applied magnetic field. If a strong magnet is placed near the ignition switch, it may not function properly (such as not shutting off power). To ensure ignition switch functions properly, DO NOT place a magnet near the ignition switch.</p> <p>The lift trucks covered in this Operating Manual can be equipped with either a key switch or keyless switch. Both options will have two positions:</p> <p>No. 1 Position: OFF position. De-energizes all electric circuits except for the horn.</p> <p>No. 2 Position: ON position. Energizes all electric circuits. The key or keyless switch will be in this position during normal operation.</p>



Model Description

HYSTER

Table 1. Operator Controls (See Figure 8 and Figure 9) (Continued)

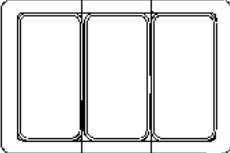
Item No.	Item	Function
5	Light Switches and Front Wiper Switch <div style="text-align: center;"> 1 2 3  BO190762 </div>	There is a rocker switch for each of the following functions: <ol style="list-style-type: none"> 1. Front Driving/Brake/Reverse/Parking lights. 2. Rear Driving light and the Strobe light or sometimes Strobe light only. 3. Front Wiper/Washer Switch. Rock switch back toward operator for ON position, forward toward front screen for OFF position and push down for window washer.



HYSTER

Model Description

Table 1. Operator Controls (See Figure 8 and Figure 9) (Continued)

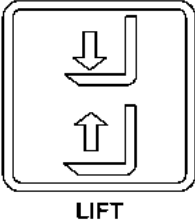
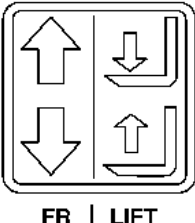

Item No.	Item	Function
6	<p>Lift/Lower Control Lever</p> <div style="text-align: center;">  <p>LIFT</p>  <p>FR LIFT BO190623</p> </div>	<p>NOTE: Manual hydraulic control levers are standard on the trucks covered in this manual. Electronic hydraulic mini-levers are available as an optional control feature for the hydraulic functions. To enable the operation of the hydraulic functions, the operator must be on the seat and the seat belt should be fastened.</p> <p>NOTE: For lift trucks equipped with optional operator presence system, the operator must be on the seat and the seat belt must be fastened.</p> <p>The lift/lower control lever can be either the first manual lever or first mini-lever to the right of the operator's seat. Pull backward toward operator to raise the carriage and forks. Push forward to lower the carriage and forks.</p> <p>For lift trucks equipped with Mast Height Limiter Switch, when mast is raised >500 mm (1.6 ft) the truck speed will slow to 3 km/h (1.8 mph).</p> <p>If the lift/lower control lever has the label shown at top left, the lift truck is equipped with a MONOTROL® pedal.</p> <p>If the lift/lower control lever has the label shown at bottom left, the lift truck is equipped with a standard accelerator pedal.</p>



Model Description

HYSTER

Table 1. Operator Controls (See Figure 8 and Figure 9) (Continued)



Item No.	Item	Function
7	<p>Tilt Control Lever</p> <div style="text-align: center;">  <p>TILT</p>  <p>RTST BO190624</p> </div>	<p>NOTE: Manual hydraulic control levers are standard on the trucks covered in this manual. Electronic hydraulic mini-levers are available as an optional control feature for the hydraulic functions. To enable the operation of the hydraulic functions, the operator must be on the seat and the seat belt should be fastened.</p> <p>NOTE: For lift trucks equipped with optional operator presence system, the operator must be on the seat and the seat belt must be fastened.</p> <p>The tilt control lever can be either the second manual lever or second mini-lever to the right of the operator's seat. Push the lever forward to tilt the mast and forks forward. Pull the lever backward toward operator to tilt the mast and forks backward.</p>



HYSTER

Model Description

Table 1. Operator Controls (See Figure 8 and Figure 9) (Continued)

Item No.	Item	Function
7	Tilt Control Lever (Cont) <div style="text-align: center;">  <p>TILT</p>  <p>RTST</p> <p>BO190624</p> </div>	<p>On the standard lift truck, the manual lever or mini-lever has the label shown at top left.</p> <p>These trucks can be equipped with the Return to Set Tilt (RTST) option if truck has electronic hydraulic mini-levers. The RTST option automatically stops the tilt function at a set point. To override the RTST option, press the override button located directly behind the tilt mini-lever and push the tilt mini-lever forward or pull backward.</p> <p>If the RTST option is installed on the lift truck, the mini-lever has the label shown at the bottom left.</p>



Model Description

HYSTER

Table 1. Operator Controls (See Figure 8 and Figure 9) (Continued)

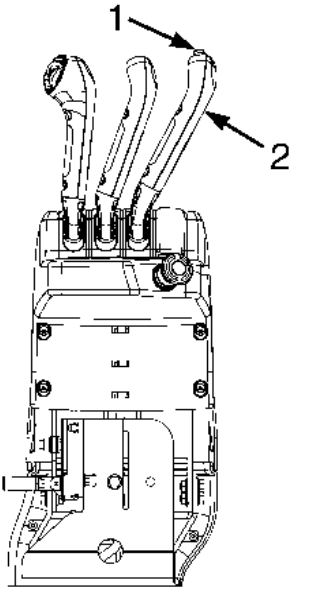
Item No.	Item	Function
8	<p>Manual Control Lever for Auxiliary Hydraulic Functions (3rd Lever)</p>  <p style="text-align: center;">BO190437</p> <p>1. CLAMP BUTTON 2. THIRD LEVER</p>	<p>NOTE: Manual hydraulic control levers are standard on the trucks covered in this manual. Electronic hydraulic mini-levers are available as an optional control feature for the hydraulic functions. To enable the operation of the hydraulic functions, the operator must be on the seat and the seat belt should be fastened.</p> <p>NOTE: For lift trucks equipped with optional operator presence system, the operator must be on the seat and the seat belt must be fastened.</p> <p>The third manual control lever is installed to the right of the manual tilt control lever. This lever can have two methods of operation, depending on the attachment.</p> <p>Trucks without clamp attachment: The lever is operated by moving it forward or backward. The lever is spring loaded to return to the neutral position when released.</p>



HYSTER

Model Description

Table 1. Operator Controls (See Figure 8 and Figure 9) (Continued)

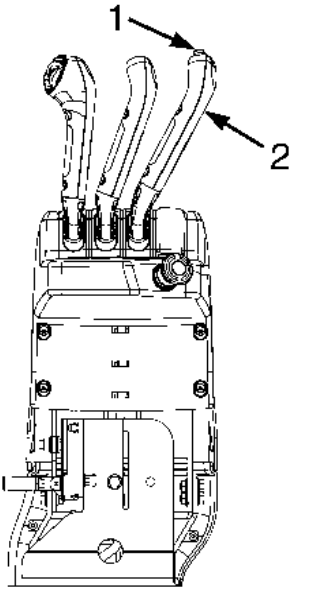
Item No.	Item	Function
8	<p>Manual Control Lever for Auxiliary Hydraulic Functions (3rd Lever)</p>  <p style="text-align: center;">BO190437</p> <p>1. CLAMP BUTTON 2. THIRD LEVER</p>	<p>NOTE: If truck is equipped with a three function control valve, three levers and clamp attachment, the last (3rd) lever controls clamp functions.</p> <p>Trucks with clamp attachment: The button on the lever enables clamp function. Lever movement is inhibited until button is pressed.</p> <p>Press the button and pull backward (toward the operator to close the clamp).</p> <p>To release the clamp, press the button and push lever forward (away from the operator).</p> <p>If there is no lever activity for approximately 4 seconds, lever movement will be inhibited.</p>



Model Description

HYSTER

Table 1. Operator Controls (See Figure 8 and Figure 9) (Continued)

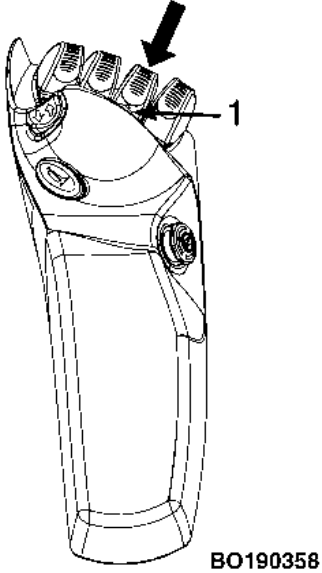
Item No.	Item	Function
8	<p>Electronic Control Mini-Lever for Auxiliary Hydraulic Functions (3rd Mini-Lever)</p>  <p>BO190358</p> <p>1. CLAMP BUTTON</p>	<p>NOTE: To operate the mini-levers, the operator must be on the seat. For lift trucks equipped with optional operator presence system, the operator must be on the seat and the seat belt must be fastened.</p> <p>The third electronic control mini-lever is installed to the right of the electronic tilt control lever. This mini-lever can have two methods of operation, depending on the attachment.</p> <p>Trucks without clamp attachment: The mini-lever is operated by moving it forward or back. The lever is spring loaded to return to the neutral position when released.</p>

HYSTER

Model Description

Table 1. Operator Controls (See Figure 8 and Figure 9) (Continued)

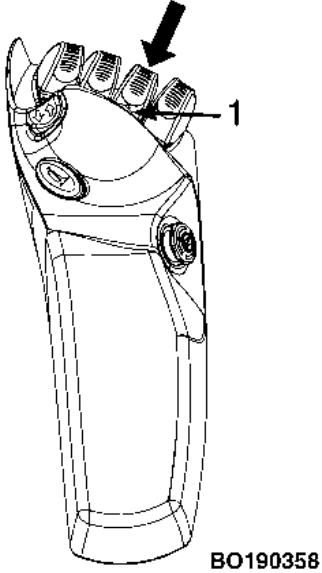
Item No.	Item	Function
8	<p>Electronic Control Mini-Lever for Auxiliary Hydraulic Functions (3rd Lever) (Cont)</p>  <p>BO190358</p> <p>1. CLAMP BUTTON</p>	<p>NOTE: If truck is equipped with a three function control valve, three mini-levers and clamp attachment, the last (3rd) lever controls clamp functions.</p> <p>Trucks with clamp attachment: The button on the MLM enables clamp function in software.</p> <p>Pull backward on the mini-lever to close the clamp.</p> <p>To release the clamp, press the button and push mini-lever forward.</p> <p>If there is no mini-lever activity for approximately 4 seconds, moving the mini-lever forward will have no effect.</p>



Model Description

HYSTER

Table 1. Operator Controls (See Figure 8 and Figure 9) (Continued)

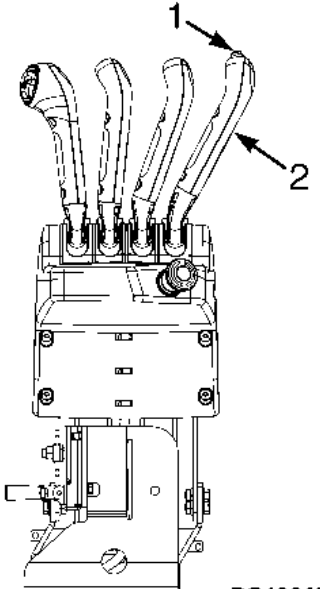
Item No.	Item	Function
9	<p>Manual Control Lever for Auxiliary Hydraulic Functions (4th lever)</p>  <p>BO190421</p> <p>1. CLAMP BUTTON 2. FOURTH LEVER</p>	<p>NOTE: Manual hydraulic control levers are standard on the trucks covered in this manual. Electronic hydraulic mini-levers are available as an optional control feature for the hydraulic functions. To enable the operation of the hydraulic functions, the operator must be on the seat and the seat belt should be fastened.</p> <p>NOTE: For lift trucks equipped with optional operator presence system, the operator must be on the seat and the seat belt must be fastened.</p> <p>The fourth manual control lever is installed to the right of the third manual control lever. This lever can have two methods of operation, depending on the attachment.</p> <p>Trucks without clamp attachment: The lever is operated by moving it forward or backward. The lever is spring loaded to return to the neutral position when released.</p>

HYSTER

Model Description

Table 1. Operator Controls (See Figure 8 and Figure 9) (Continued)

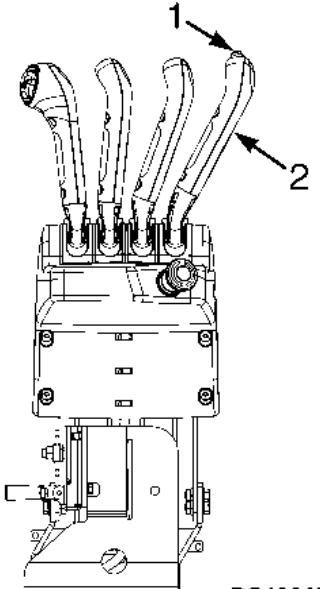
Item No.	Item	Function
9	<p>Manual Control Lever for Auxiliary Hydraulic Functions (4th lever)</p>  <p>BO190421</p> <p>1. CLAMP BUTTON 2. FOURTH LEVER</p>	<p>NOTE: If truck is equipped with four function control valve, four levers and clamp attachment, the last (4th) lever controls clamp functions.</p> <p>Trucks with clamp attachment: The button on the lever enables clamp function. Lever movement is inhibited until button is pressed.</p> <p>Press the button and pull backward (toward the operator to close the clamp).</p> <p>To release the clamp, press the button and push lever forward (away from the operator).</p> <p>If there is no lever activity for approximately 4 seconds, lever movement will be inhibited.</p>



Model Description

HYSTER

Table 1. Operator Controls (See Figure 8 and Figure 9) (Continued)

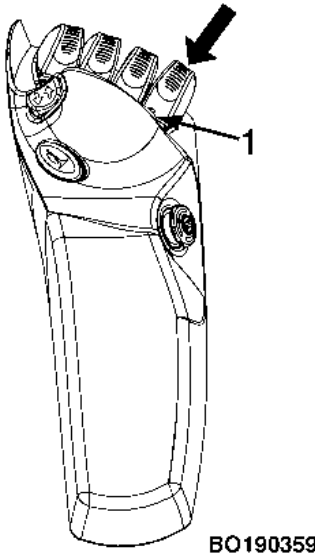
Item No.	Item	Function
9	<p>Electronic Control Mini-Lever for Auxiliary Hydraulic Functions (4th mini-lever)</p>  <p>BO190359</p> <p>1. DUAL FUNCTION OR CLAMP BUTTON</p>	<p>NOTE: To operate the mini-levers, the operator must be on the seat. For lift trucks equipped with optional operator presence system, the operator must be on the seat and the seat belt must be fastened.</p> <p>The fourth electronic control lever is installed to the right of the third electronic control lever. This lever can have two methods of operation, depending on the attachment.</p> <p>Trucks without clamp attachment, four mini-levers, and four function control valve: The mini-lever is operated by moving it forward or backward. The mini-lever is spring loaded to return to the neutral position when released.</p> <p>Trucks without clamp attachment, four mini-levers, and five function control valve: The mini-lever is dual function.</p>



HYSTER

Model Description

Table 1. Operator Controls (See Figure 8 and Figure 9) (Continued)

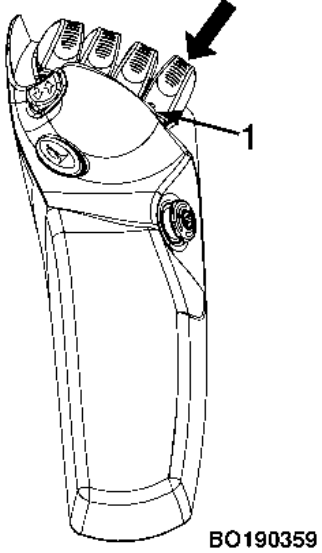
Item No.	Item	Function
9	<p>Electronic Control Mini-Lever for Auxiliary Hydraulic Functions (4th mini-lever)</p>  <p>BO190359</p> <p>1. DUAL FUNCTION OR CLAMP BUTTON</p>	<p>NOTE: If truck is equipped with four function control valve, four mini-levers and clamp attachment, the last (4th) mini-lever controls clamp functions.</p> <p>Trucks with clamp attachment: The button on the MLM enables clamp function in software. Pull back on the mini-lever to close the clamp.</p> <p>To release the clamp, press the button and push mini-lever forward.</p>

Model Description

HYSTER

Table 1. Operator Controls (See Figure 8 and Figure 9) (Continued)

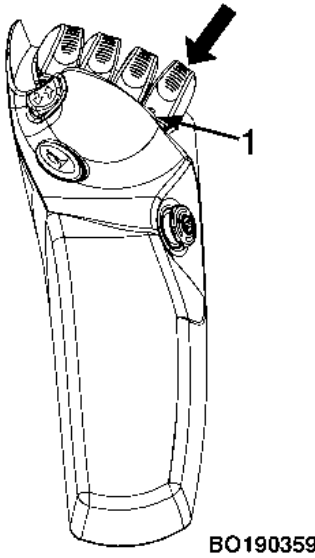
Item No.	Item	Function
9	<p>Electronic Control Mini-Lever for Auxiliary Hydraulic Functions (4th mini-lever)</p>  <p>BO190359</p> <p>1. DUAL FUNCTION OR CLAMP BUTTON</p>	<p>NOTE: If truck is equipped with five function control valve, four mini-levers and clamp attachment, the 4th mini-lever controls clamp function and the 3rd mini-lever controls the 3rd and 5th functions.</p> <p>Trucks with clamp attachment, four mini-levers, and five function control valve: The third mini-lever becomes a dual function mini-lever.</p> <p>Move the 3rd mini-lever forward or back to operator the 3rd function. Press the button and move the mini-lever forward or backward to operator the 5th function.</p> <p>Pull backward on the 4th mini-lever to close the clamp.</p> <p>To release the clamp, press the button and push the 4th mini-lever forward.</p>



HYSTER

Model Description

Table 1. Operator Controls (See Figure 8 and Figure 9) (Continued)

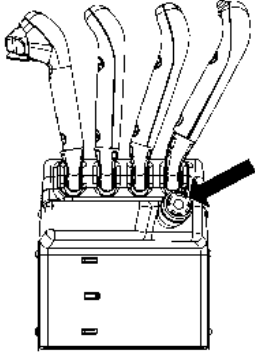
Item No.	Item	Function
10	<p>Emergency Disconnect Switch (manual levers)</p>  <p>BO190422</p>	<p>The emergency disconnect switch, on trucks equipped with manual levers, is located behind the levers.</p> <p>The operator can disconnect all electrical power to the lift truck by pushing the emergency disconnect switch down until it clicks. To reset the emergency disconnect switch and energize the electrical circuits, the operator must turn the switch clockwise until it pops up.</p>

Model Description

HYSTER

Table 1. Operator Controls (See Figure 8 and Figure 9) (Continued)

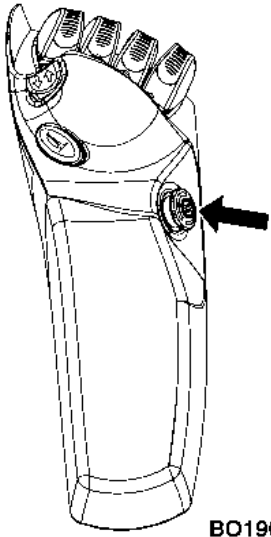
Item No.	Item	Function
10	<p>Emergency Disconnect Switch (E-Hydraulics)</p>  <p>BO190360</p>	<p>The emergency disconnect switch, on trucks equipped with E-Hydraulic mini-levers, is located on the right side of the armrest.</p> <p>The operator can disconnect all electrical power to the lift truck by pushing the emergency disconnect switch in until it clicks. To reset (reconnect) the emergency disconnect switch and energize the electrical circuits, the operator must turn the switch clockwise until it pops up.</p>



HYSTER

Model Description

Table 1. Operator Controls (See Figure 8 and Figure 9) (Continued)

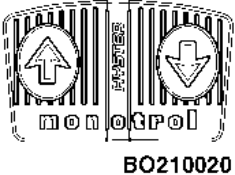
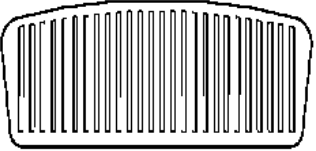
Item No.	Item	Function
11	MONOTROL® Pedal 	When the lift truck is equipped with a MONOTROL® pedal, the direction and the speed of travel is controlled by the MONOTROL® pedal. When the right (REVERSE) side of the pedal is pushed, the lift truck will move in the reverse direction. When the left (FORWARD) side of the pedal is pushed, the lift truck will move in the forward direction. The speed of the lift truck increases when the pedal is pushed further.
12	Brake Pedal 	This pedal, controlled by the operator's foot, applies the service brakes when pushed.



Model Description

HYSTER

Table 1. Operator Controls (See Figure 8 and Figure 9) (Continued)

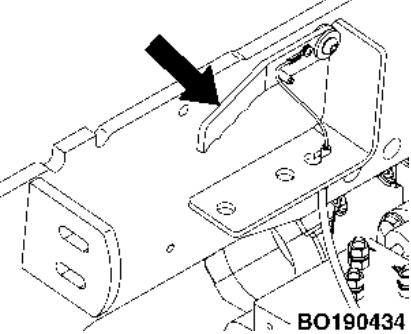
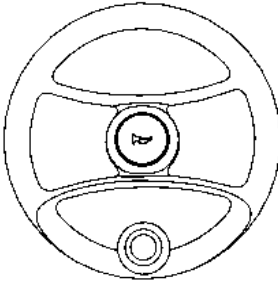
Item No.	Item	Function
13	<p>Automatic Parking Brake Manual Override Handle (Optional)</p> 	<p>The truck may be equipped with an optional Automatic Parking Brake (APB). The APB will apply a brake to the traction motor after lift truck stops. See the Operating Procedures for a more detailed description on how the APB works.</p> <p>If the lift truck loses power and has to be towed, there is a manual override handle that will disable the APB. The manual override handle is located underneath the floor mat and floor plate and mounted to the front bulkhead. To apply the manual override, remove the floor mat and floor plate and pull the handle up.</p>
14	<p>Steering Wheel</p> 	<p>The steering wheel controls the movement of the steer wheels. Rotate the steering wheel clockwise to make a right turn, and counterclockwise to make a left turn.</p>



HYSTER

Model Description

Table 1. Operator Controls (See Figure 8 and Figure 9) (Continued)

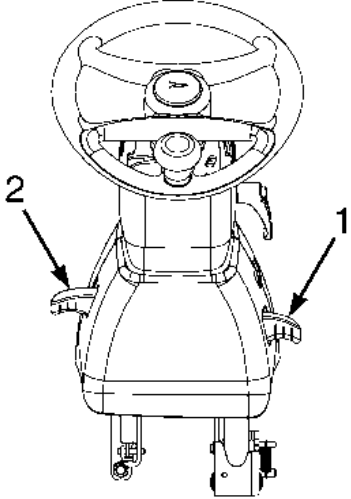
Item No.	Item	Function
15	<p>Steering Column Tilt Memory Lever (Optional)</p>  <p style="text-align: center;">BO190589</p> <p>1. TILT POSITION LEVER 2. TILT MEMORY LEVER</p>	<p>Lift the tilt position lever to adjust the steering column up or down for the operator's comfort.</p> <p>This tilt memory lever permits moving the steering column from a locked position to an upright position and back to the original locked position. Lift the lever to move the steering column to exit the truck. The lever will lock when the steering column is returned to the original position. Make sure the lever is locked before operating the lift truck.</p> <p>If steering tilt position is set at the full upright position, the steering column will not move when the tilt memory lever is lifted. Use the tilt position lever to reset the steering column to the desired position.</p>



Model Description

HYSTER

Table 1. Operator Controls (See Figure 8 and Figure 9) (Continued)

Item No.	Item	Function
16	<p data-bbox="280 496 683 531">Direction Control Switch</p> <div data-bbox="280 564 817 917"> </div> <p data-bbox="705 943 817 965">BO190431</p> <p data-bbox="280 997 981 1034">A. E-HYDRAULIC CONTROL LEVERS</p> <p data-bbox="280 1066 952 1145">B. MANUAL HYDRAULIC CONTROL LEVERS</p>	<p data-bbox="996 496 2139 805">The direction control switch is used on some lift trucks. When the lift truck is equipped with a direction control switch, it will also have an accelerator pedal instead of a MONOTROL® pedal. If the lift truck is equipped with E-Hydraulic mini-levers, the direction control switch is located on the left side of the armrest, in front of the horn button. If the lift truck is equipped with manual hydraulic levers, the direction control switch is located on the left side of the first lever.</p> <p data-bbox="996 837 2139 965">The direction control switch has two positions: Forward and Reverse. Push the switch to the top to go forward and to the bottom to go in reverse.</p>

HYSTER

Model Description

Table 1. Operator Controls (See Figure 8 and Figure 9) (Continued)

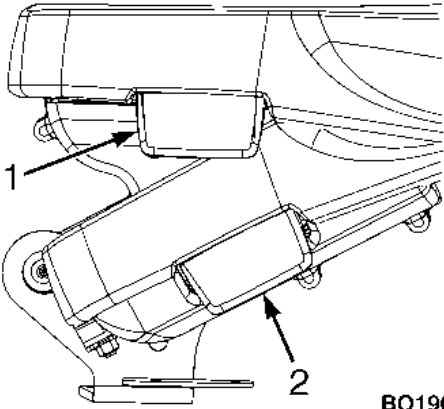
Item No.	Item	Function
	<p>Armrest Adjustment Handles, Lift Trucks With E-Hydraulic Controls (Not Shown in Figure 9)</p>  <p>BO190424</p> <p>1. SMALL ADJUSTMENT HANDLE</p> <p>2. LARGE ADJUSTMENT HANDLE</p>	<p>The armrest on lift trucks equipped with E-Hydraulic mini-levers, is adjustable for operator comfort.</p> <p>The large adjustment handle on the lower part of the slide assembly, moves the armrest up and down in a diagonal direction, to adjust the height of the armrest. Pull up on the handle and move armrest to desired height. Release handle to set armrest height.</p> <p>The smaller handle, located on the right side of the armrest cushion, moves the armrest forward and backward to adjust the distance of the mini-levers. Pull up on handle and slide armrest either forward or backward until desired distance is achieved. Release handle to set armrest distance.</p>

Model Description

HYSTER

Table 1. Operator Controls (See Figure 8 and Figure 9) (Continued)

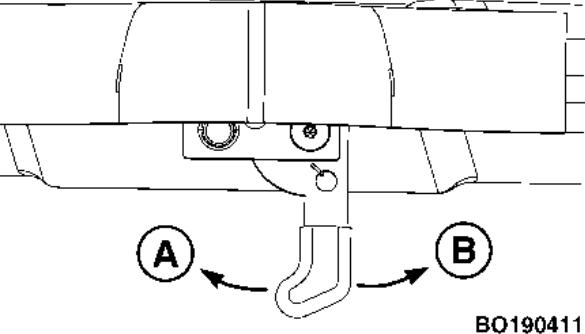
Item No.	Item	Function
	<p>Hood Latch, Lift Trucks Manufactured Before March, 2015 (Not Shown in Figure 8 and Figure 9)</p>  <p>A. LOCKED POSITION B. OPEN POSITION</p>	<p>NOTE: Before raising the hood, move the steering column to the forward position and slide the seat all the way back. For lift trucks equipped with Rapid/Fast Charging, slide the seat all the way forward. If necessary, move the armrest all the way back if lift truck is equipped with E-Hydraulic control levers. If lift truck is equipped with manual hydraulic levers, release the latch for the control lever assembly and move the assembly to the forward position before raising the hood.</p> <p>The latch and hood release handle are located in the center of the hood.</p> <p>Release the hood latch. Raise hood to UP position using the hood handle.</p> <p>To close the hood, lower the hood and push down until the latch clicks twice.</p>

HYSTER

Model Description

Table 1. Operator Controls (See Figure 8 and Figure 9) (Continued)

Item No.	Item	Function
	<p>Hood Latch, Lift Trucks Manufactured After February, 2015 (Not Shown in Figure 8 and Figure 9)</p> <p style="text-align: right;">BO191142</p> <p>A. RELEASE DIRECTION 1. HOOD RELEASE LEVER 2. HOOD HANDLE 3. HOOD LATCH ASSEMBLY</p>	<p>NOTE: Before raising the hood, move the steering column to the forward position and slide the seat all the way back. For lift trucks equipped with Rapid/Fast Charging, slide the seat all the way forward. If necessary, move the armrest all the way back if lift truck is equipped with E-Hydraulic control levers. If lift truck is equipped with manual hydraulic levers, release the latch for the control lever assembly and move the assembly to the forward position before raising the hood.</p> <p>The latch and hood release handle are located in the center of the hood.</p> <p>Release the hood latch. Raise hood to UP position using the hood handle.</p> <p>To close the hood, lower the hood and push down until the latch clicks once. Try to lift the hood to make sure the hood is locked down. The hood must be locked in the down position during lift truck operation.</p>



Model Description

HYSTER

Table 1. Operator Controls (See Figure 8 and Figure 9) (Continued)

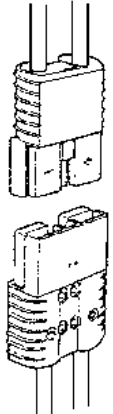
Item No.	Item	Function
	<p>Battery Connector (Not Shown in Figure 8 and Figure 9)</p>  <p>BO190504</p>	<p>⚠ CAUTION Make sure both halves of the connectors are the same type and color. Make sure the voltage of the battery is the same as specified on the Nameplate. The halves of the connector must be joined for operation. Separate the halves of the connector to disconnect the battery.</p> <p>The battery connector is in two parts. One half of the connector is attached to the battery cables and has a handle as shown. The other half of the connector is connected to the electrical system of the lift truck.</p>

HYSTER

Model Description

Table 1. Operator Controls (See Figure 8 and Figure 9) (Continued)

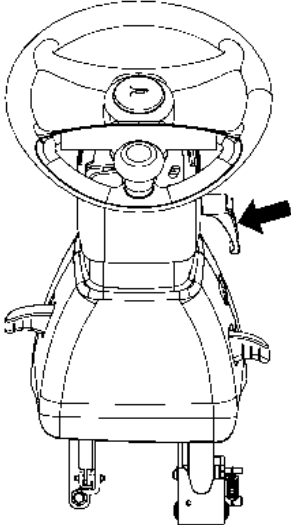
Item No.	Item	Function
	<p>Steering Column Telescopic Locking Handle (Optional) (Not Shown in Figure 8 and Figure 9)</p>  <p>BO190590</p>	<p>Loosen the telescopic column locking handle. Turn the locking handle counterclockwise and slide the steering column in or out to desired setting. Turn the telescopic locking handle clockwise to lock steering column at the desired height.</p>

Model Description

HYSTER

Table 1. Operator Controls (See Figure 8 and Figure 9) (Continued)

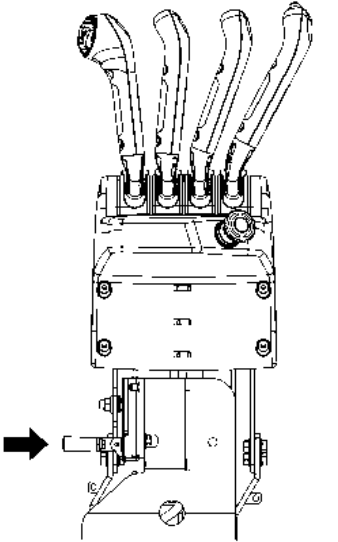
Item No.	Item	Function
	<p>Release Lever, Manual Hydraulic Control Levers (Not Shown in Figure 8)</p>  <p>BO190423</p>	<p>To move the manual hydraulic control lever assembly so that the hood can be opened, pull the release lever up and push the manual hydraulic control lever assembly toward the dash panel. To put the manual hydraulic control lever assembly back into position for operator usage, push the manual hydraulic control lever assembly toward the hood. The lever assembly will click once and lock into place.</p>

HYSTER

Model Description

Table 1. Operator Controls (See Figure 8 and Figure 9) (Continued)

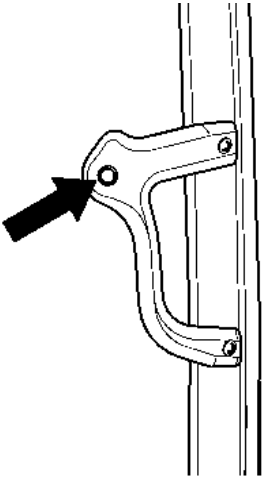
Item No.	Item	Function
	<p>Horn Button on Overhead Guard Leg (Not Shown in Figure 8 or Figure 9)</p>  <p>BO190528</p>	<p>The lift trucks in this Operating Manual are equipped with a handle on the right rear overhead guard leg with a horn button on it.</p>



Model Description

HYSTER

Table 1. Operator Controls (See Figure 8 and Figure 9) (Continued)

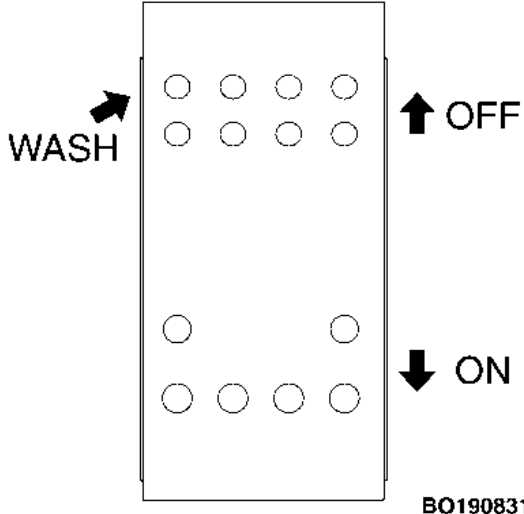
Item No.	Item	Function
17	<p>Rear Wiper Switch</p>  <p>BO190831</p>	<p>The rear wiper switch is located in the roof panel over the right shoulder of lift truck operator. Rock the switch forward toward the front of the lift truck to turn ON the rear wiper. Rock the switch toward the rear of the lift truck to turn OFF the rear wiper. To activate the rear wiper washer, rock the switch to the ON position and press up toward the roof panel.</p>



HYSTER

Model Description

Table 1. Operator Controls (See Figure 8 and Figure 9) (Continued)

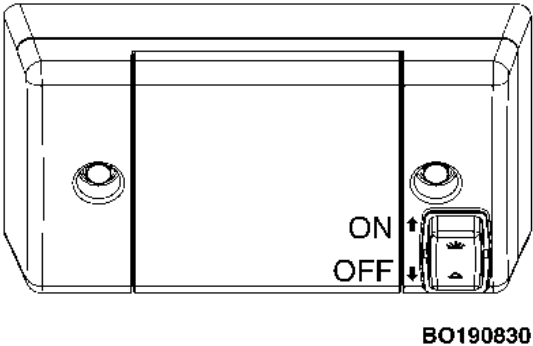
Item No.	Item	Function
18	<p>Dome Lamp</p> 	<p>The dome lamp is located in the roof panel over the left shoulder of the lift truck operator. Locate the rocker switch on the face of the dome lamp. Push the switch toward the front of the lift truck to turn ON the dome lamp, push the switch toward the back of the lift truck to turn the dome lamp OFF.</p>



Display Panel Features

HYSTER

Display Panel Features

Display Panel

See **Figure 11**.

NOTE: The features listed below are standard display panel functions.

- LCD (Liquid Crystal Display) Screen.
- Battery Discharge Indicator (BDI) (with lift interrupt when enabled).
- Status Codes.
- System time/date display.
- Hourmeter of traction and lift pump times.
- Numeric push key pad.
- Provides four driving Performance Modes that are accessed through the key pad.

NOTE: The features listed below must be enabled with a software update prior to use on the lift truck.

- Allows preassigned operator passwords to control operator access to vehicle.
- Allows scheduled maintenance reminders to be programmed in and will alert the operator through an audible and visual alarm when scheduled maintenance is due.
- Provides the ability to set up an operator checklist where the operator must answer Yes or No to a set of questions before lift truck will start.
- Hydraulic fluid low icon. This icon will appear if the system detects low hydraulic fluid. Available with the Hydraulic Fluid Level Monitoring option.
- Hydraulic filter restriction icon. This icon will appear if the system detects a restriction in the hydraulic filter. This is an optional feature.



HYSTER

Display Panel Features

Display Panel Keys

WARNING

If any of the instruments, levers, or pedals do not operate as described in the following tables, report the problem immediately. Injury to personnel can occur if the instruments, levers, or pedals do not operate as described in the following table. **DO NOT** operate the lift truck until the problem is corrected.

The display panel is equipped with 10 numeric keys, two arrow keys (left and right arrows), and two symbol keys (the STAR key and the POUND key). See **Figure 11**.

If multiple keys are pressed at the same time, the display panel will ignore all keys. If a key has already been

pressed and a second one is pressed right afterward, the display panel will ignore the second key.

All key presses are accepted for a single entry and key entries cannot be repeated by holding down the key. For example, holding the **3** key down while entering a password number, will only result in one instance of **3** being entered regardless of how long the user presses the **3** key. To enter multiple **3** the user must press the **3** key multiple times.

The lift trucks covered in this **Operating Manual** can be equipped with several different options and configurations. Depending on the equipment on the lift truck, the key functions described in **Table 2** will vary and may not pertain to your lift truck.

Display Panel Features

HYSTER

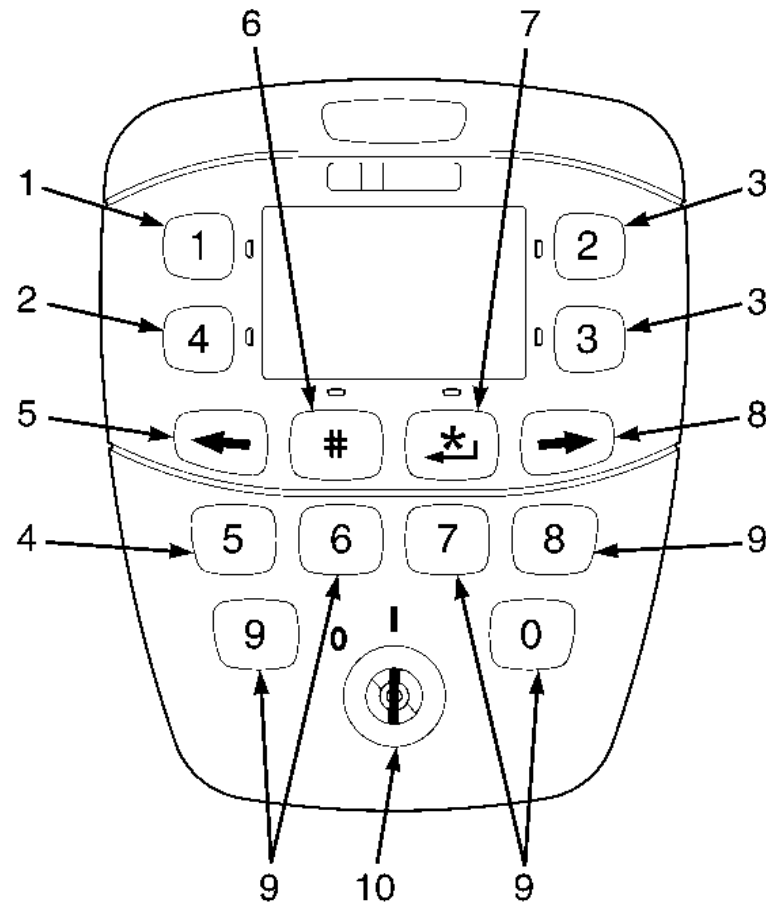

BO190562

Figure 11. Display Panel Keys



HYSTER

Display Panel Features

Table 2. Display Panel Keys (See Figure 11)

Item No.	Item	Function
1	1 Key	<p>When an operator is in the <i>Password Screen</i>, if enabled, for entering passwords, this key allows entry of the number 1 for password purposes.</p> <p>Once a password has been successfully entered, or if a password is not required, the display panel will go to the <i>Operator Screen</i>. This screen contains all the necessary components for normal operation of the lift truck. In this screen Key 1 is enabled to decrease Performance Mode; press the 1 key to go to the next lower level of performance; level 1 performance mode is the slowest and level 4 is the fastest.</p> <p>When an operator, if authorized, is in any of the additional menus that are available (Calibrations, Diagnostics, and Truck Setup menus) the 1 key is enabled to enter the number 1 for data entry purposes.</p>



Display Panel Features

HYSTER

Table 2. Display Panel Keys (See Figure 11) (Continued)

Item No.	Item	Function
2	4 Key	<p>When an operator is in the <i>Password Screen</i>, if enabled, for entering passwords, this key allows entry of the number 4 for password purposes.</p> <p>Once a password has been successfully entered, the display panel will go to the <i>Operator Screen</i>. This screen contains all the necessary components for normal operation of the lift truck. In this screen, Key 4 is enabled to increase Performance Mode; press the 4 key to go to the next highest level of performance; level 1 performance mode is the slowest and level 4 is the fastest.</p> <p>When an operator, if authorized, is in any of the additional menus that are available (Calibrations, Diagnostics, and Truck Setup menus) the 4 key is enabled to enter the number 4 for data entry purposes.</p>



HYSTER

Display Panel Features

Table 2. Display Panel Keys (See Figure 11) (Continued)

Item No.	Item	Function
3	2 and 3 Keys	<p>When an operator is in the <i>Password Screen</i>, if enabled, for entering passwords, these keys allow entry of the number 2 and 3 for password purposes.</p> <p>Once a password has been successfully entered, or if a password is not required, the display panel will go to the <i>Operator Screen</i>.</p> <p>When an operator, if authorized, is in any of the additional menus that are available (Calibrations, Diagnostics, and Truck Setup menus) the 2 and 3 keys allow the operator to scroll up or down within the menu. Press the 2 key to scroll up and press the 3 key to scroll down.</p> <p>When an operator, if authorized, is working in any of the menus, other than the <i>Password</i> menu, is prompted to enter a data value that contains numbers, the scrolling features of the 2 and 3 keys will be disabled and keys 2 and 3 can be used to enter numeric values. Once the numeric data value has been entered and the Enter key pressed, the scrolling feature for keys 2 and 3 will be enabled again.</p>



Display Panel Features

HYSTER

Table 2. Display Panel Keys (See Figure 11) (Continued)

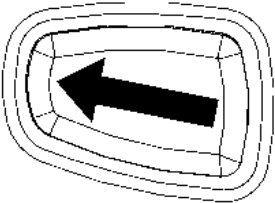
Item No.	Item	Function
4	5 Key	<p>When an operator is in the <i>Password Screen</i>, if enabled, for entering passwords, this key is enabled to enter the number 5 for password purposes.</p> <p>Once a password has been successfully entered, or if a password is not required, the display panel will to the <i>Operator Screen</i>.</p> <p>When an operator, if authorized, is in any of the additional menus that are available (Calibrations, Diagnostics, and Truck Setup menus) the 5 key is enabled to enter the number 5 for data entry purposes.</p>
5	<p>Scroll Back (Left Arrow Key)</p>  <p>BO190369</p>	<p>This key is used for the following functions:</p> <ul style="list-style-type: none"> • Decreasing the value of a selected operating function. • Scrolling backward through a list of possible menu selections.



HYSTER

Display Panel Features

Table 2. Display Panel Keys (See Figure 11) (Continued)

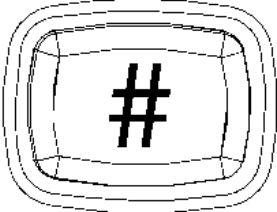
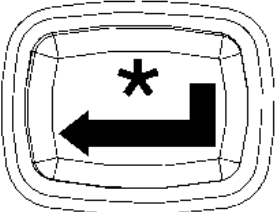
Item No.	Item	Function
6	Pound Key  BO190370	If the Operator Checklist is enabled on the lift truck, the Pound Key is used to indicate an issue with the current item in the list. See Operator Checklist in the Operating Procedures section for more information on using the Operator Checklist.
7	Enter Key (STAR Key)  BO190371	This key is used for menu entry and menu navigation. Use the STAR key to select a menu to be viewed. Within the selected menu, use the STAR key to select sub menus associated with the selected menu.



Display Panel Features

HYSTER

Table 2. Display Panel Keys (See Figure 11) (Continued)

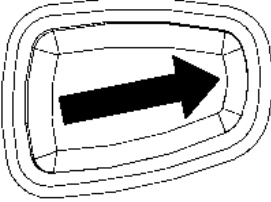
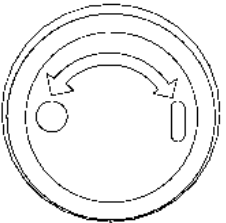
Item No.	Item	Function
8	Scroll Forward (Right Arrow Key) 	This key is used for the following functions: <ul style="list-style-type: none"> Increasing the value of a selected operating function. Scrolling forward through a list of possible menu selections.
9	6, 7, 8, 9, and 0 Keys	The 6, 7, 8, 9, and 0 keys are enabled to enter the numbers 6, 7, 8, 9, and 0 for data entry purposes.
10	Keyless Start Switch or Key Switch 	See Table 1 for more information.



HYSTER

Display Panel Features

Display Panel - LCD Screen and Warning and Indicator Lights

The LCD screen uses a series of icons and numeric values to communicate important truck information to the operator, supervisor, and service technician. See **Figure 12**.

The warning and indicator lights described in **Table 3** appear when the LCD screen is displaying the *Operator Screen*. The *Operator Screen* contains all the components necessary for normal operation of the lift truck. When the lift truck power is first turned **ON**, all icons in **Table 3** will illuminate. After 10 seconds, the seat belt, low brake fluid, service due (if equipped), motor temperature icons, and low hydraulic fluid (if equipped) will no longer be illuminated and will illuminate again only if there is a problem in that particular area.

The following icons and information is displayed at all times on the LCD screen when the truck is running, and the LCD screen is displaying the *Operator Screen*. See **Figure 12** and **Table 3**:

- The current performance mode the truck is operating under.
- The Battery Display Indicator (BDI).
- The direction indicators showing which direction the truck is traveling in.
- The neutral/park brake indicator.
- The truck hourmeter.
- System time.

For more information and detailed description of the other warning and indicator lights that can be displayed on the LCD screen and are not covered in this **Operating Manual**, see the sections **User Interface - Supervisor 2200 SRM 1335** or **User Interface - Service Technician 2200 SRM 1336**.

Display Panel Features

HYSTER

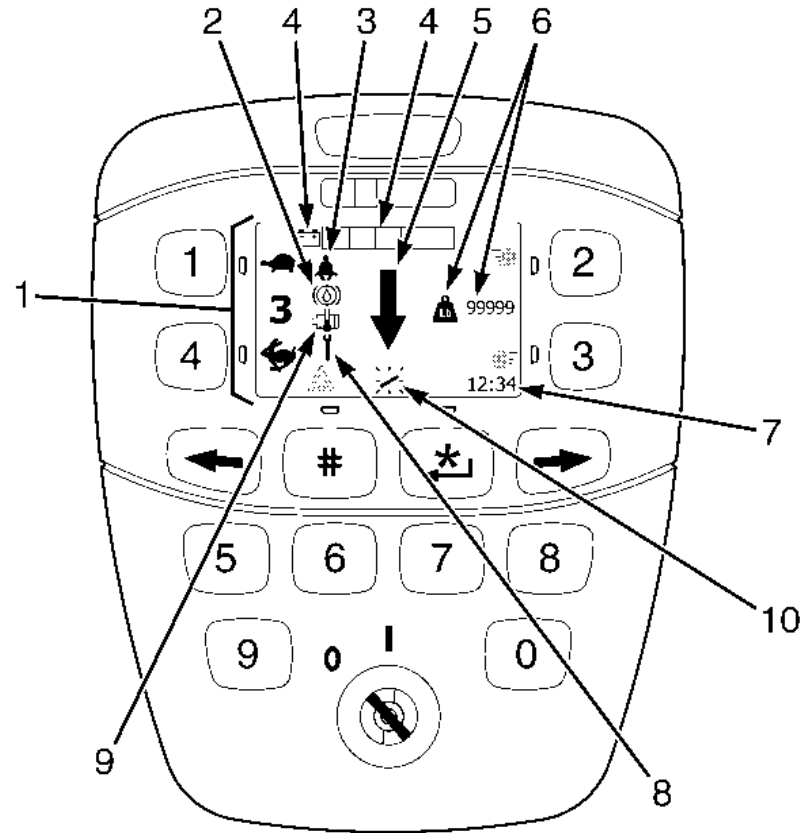

BO190612



Figure 12. Display Panel - LCD Screen and Warning and Indicator Lights



HYSTER

Display Panel Features

Table 3. Display Panel - LCD Screen and Warning and Indicator Lights (See Figure 12)

Item No.	Item	Function
1	Indicator Light, Performance Mode  BO190563	<p>There are four performance modes to choose from. Each mode changes acceleration and speed.</p> <p>The tortoise icon on the top decreases the performance mode and the hare on the bottom increases the performance mode. The numeric value (numbers 1 through 4) in the middle indicates which performance mode the truck is currently in. The number 1 is the slowest and the number 4 is the fastest.</p> <p>Push the 1 key, next to the tortoise, to decrease the performance mode. Push the 4 key, next to the hare, to increase the performance mode. The lift truck will now operate within the parameters set for that mode number until the performance mode is changed again.</p>
2	Warning Light, Low Brake Fluid 	<p> CAUTION</p> <p>Do not continue to operate lift truck if light is on. Damage to equipment may occur.</p> <p>The low brake fluid icon will illuminate when the brake fluid sensor indicates a low brake fluid condition in the brake reservoir.</p>



Display Panel Features

HYSTER

Table 3. Display Panel - LCD Screen and Warning and Indicator Lights (See Figure 12) (Continued)

Item No.	Item	Function
3	<p>Warning Light, Fasten Seat Belt</p>  <p>BO190374</p>	<p>⚠ WARNING Always fasten seat belt when operating the lift truck. Serious injury to personnel may occur if seat belt is not fastened.</p> <p>This icon will stay illuminated for approximately 10 seconds when the <i>Operator Screen</i> first appears on the display panel after the key or keyless switch has been turned to the ON position. The light will disappear after 10 seconds or until the screen is changed, whichever occurs first.</p> <p>The fasten seat belt icon will also illuminate if the operator returns to the seat after being off of it for more than 10 seconds.</p>



HYSTER

Display Panel Features

Table 3. Display Panel - LCD Screen and Warning and Indicator Lights (See Figure 12) (Continued)

Item No.	Item	Function
4	<p>Indicator Light, Battery Display Indicator (BDI)</p>  <p style="text-align: center;">BO190377</p>	<p>⚠ CAUTION DO NOT operate the lift truck when the Battery State-of-Charge (BSOC) is too low and the battery icon is flashing. Continued operation with a low battery can cause damage to the battery and lift truck.</p> <p>A bar graph, representing the Battery State-of-Charge (BSOC) is visible on the LCD screen at all times while the <i>Operator Screen</i> is displayed.</p> <p>When the battery is fully charged, the bar graph will be completely shaded. As the battery discharges, shaded blocks will disappear from the top of the graph on down.</p> <p>When the battery drops below 25 percent BSOC, an audible alarm will sound and the battery icon will begin to flash, indicating that the battery charge is too low and must be charged soon.</p> <p>Continued operation will cause lift-interrupt (if enabled) to occur to help prevent battery damage. Lift-interrupt prevents the operator from lifting loads and saves enough battery power for operator to move lift truck to a battery recharger. At lift-interrupt, there are no segments (bars) displayed, and the Battery symbol is flashing.</p>



Display Panel Features

HYSTER

Table 3. Display Panel - LCD Screen and Warning and Indicator Lights (See Figure 12) (Continued)

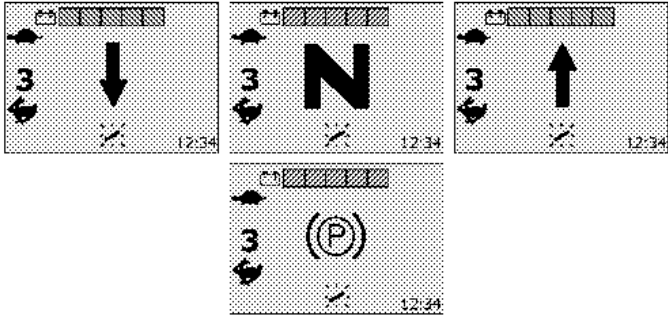
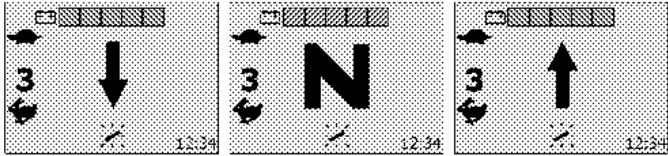
Item No.	Item	Function
5	<p>Indicator Light, Direction Indicators</p>  <p style="text-align: right;">B0191125</p>	<p>The direction indicator lights indicate which direction the lift truck is currently traveling.</p> <p>With software versions less than 4.32, when a direction of travel has been selected, the corresponding direction arrow (up for Forward, down for Reverse) will illuminate.</p> <p>When the parking brake has been applied, the N or Arrows will disappear and the parking brake applied icon will take its place.</p> <p>When the parking brake is disengaged, the N or Arrows will reappear.</p>
5	<p>Indicator Light, Parking Brake Not Applied Direction Indicators</p>  <p style="text-align: right;">B0191126</p>	<p>With software versions 4.32 and greater, the direction indicator lights indicate which direction the lift truck is set to travel. The corresponding direction arrow (up for Forward, down for Reverse) will illuminate.</p> <p>When the parking brake is disengaged, the N or Arrows (based on direction selected) will appear.</p>



HYSTER

Display Panel Features

Table 3. Display Panel - LCD Screen and Warning and Indicator Lights (See Figure 12) (Continued)

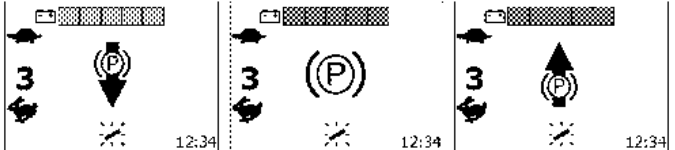
Item No.	Item	Function
5	<p>Indicator Light, Parking Brake Applied Direction Indicators</p>  <p style="text-align: center;">BO191127</p>	<p>With software versions 4.32 and greater, when a direction of travel has been selected, the corresponding arrow (up for Forward, down for Reverse) will illuminate.</p> <p>These symbols will illuminate whenever the parking brake has been applied.</p>



Display Panel Features

HYSTER

Table 3. Display Panel - LCD Screen and Warning and Indicator Lights (See Figure 12) (Continued)

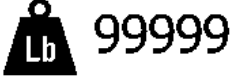
Item No.	Item	Function
6	<p>Indicator Light, Load Weight Indicator</p>  <p>BO190385</p>	<p>The Load Weight Indicator option is available. If this option is enabled, this icon will appear whenever there is a load on the forks.</p> <p>When the operator lifts up a load, the load weight will be displayed on the LCD screen in place of the system time. The load weight will continue to be displayed on the LCD screen as long as the load is on the forks, and will remain on the screen for five seconds after the load has been removed from the forks. After the five seconds have elapsed and another load is not put on the forks, the system time will reappear in place of the load weight icon.</p> <p>The load weight will be displayed in either pounds (lb) or kilograms (kg). The unit of measure to be displayed is set up by either a supervisor or service technician. See the Operating Procedures section for procedures to set up and calibrate the load weight.</p>
7	<p>Indicator Light, System Time</p> <p>12:34</p> <p>BO190379</p>	<p>This icon displays the time of day and is located below the hourmeter. The time format is adjustable by either a supervisor or service technician.</p>



HYSTER

Display Panel Features

Table 3. Display Panel - LCD Screen and Warning and Indicator Lights (See Figure 12) (Continued)



Item No.	Item	Function
8	Warning Light, Service Due Light 	<p>The service due icon will illuminate when either an active fault is present in the system or when scheduled maintenance is due or almost due, if lift truck is equipped with this feature.</p> <p>When an active fault is present in the system, the wrench symbol will flash on and off repeatedly. The Status Code for the fault will also be displayed on the LCD screen. Status Codes indicate to the operator that a possible malfunction or incorrect truck use has occurred. Status Codes are code numbers for a symptom or malfunction. Have an authorized service technician check and repair the lift truck if a status code number appears.</p> <p>When scheduled maintenance is due or almost due, the service due light will illuminate and be displayed continuously until scheduled service is performed.</p> <p>If maintenance is not performed before the scheduled time, lift truck operation will decrease by 50% until maintenance is performed. The service technician or supervisor must also set the memory for the next maintenance time to allow normal operation again.</p>



Display Panel Features

HYSTER

Table 3. Display Panel - LCD Screen and Warning and Indicator Lights (See Figure 12) (Continued)



Item No.	Item	Function
8	Warning Light, Service Due Light (Cont) 	If there is a restriction in the hydraulic filter, the service due icon will illuminate and the message "Hydraulic filter restriction" will appear on the display panel. The hydraulic filter restriction feature is an optional feature.
9	Warning Light, Motor Temperature High Warning  BO190380	<p>⚠ CAUTION DO NOT operate the lift truck when the motor temperature is too high. Damage to the hydraulic system can occur.</p> <p>This icon will illuminate and stay illuminated when one of the following things have happened: the traction motor or hydraulic pump motor temperature has become too high.</p> <p>If this icon appears, the lift truck must be checked by a service technician right away. Continued operation of the lift truck when this icon is illuminated, will cause damage to the hydraulic system.</p>



HYSTER

Display Panel Features

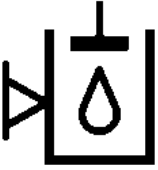
Table 3. Display Panel - LCD Screen and Warning and Indicator Lights (See Figure 12) (Continued)

Item No.	Item	Function
10	Steer Angle Indicator 	The steer angle indicator shows the current forward steering direction when the accelerator or MONOTROL® pedal is depressed.
	Warning Light, Hydraulic Fluid Level Low (Not Shown in Figure 12)  BO190381	<p> CAUTION DO NOT operate the lift truck when the hydraulic fluid is low. Damage to the hydraulic system can occur.</p> <p>This icon is only available if the lift truck is equipped with the Hydraulic Fluid Level Monitoring option. If the system detects a low hydraulic fluid level, this icon will illuminate and stay illuminated until hydraulic fluid has been added to the hydraulic system. The icon is located below the wrench (Service Due) icon.</p>



Display Panel Features

HYSTER

Table 3. Display Panel - LCD Screen and Warning and Indicator Lights (See Figure 12) (Continued)

Item No.	Item	Function
	<p>Indicator Light, Truck Hourmeter (Not Shown in Figure 12)</p>  <p>99999</p> <p>BO190378</p>	<p>The hourmeter displays the number of hours of operation on the lift truck. The hourmeter contains 5 digits and an hourglass icon. The hourmeter will always be visible to the operator as long as the display panel has the <i>Operator Screen</i> displayed.</p> <p>Turning the key, or keyless switch to the OFF position, or pressing the scroll forward key (see Figure 11 and Table 2) with the key or keyless switch in the OFF position, will display the truck hourmeter and the pump hourmeter for five seconds. See Figure 13.</p>

HYSTER

Normal Sequence of Operation - Display Panel

Following is the normal sequence that occurs after the operator is on the seat with the battery connected:

- After the key or keyless switch is moved to the **ON** position, the LCD screen will display the *Operator Screen* where the icons shown in **Figure 11**, **Figure 12**, and **Table 2** will appear on the LCD screen. After 10 seconds, the seat belt, low brake fluid, and motor temperature icons will no longer be illuminated and will illuminate again only if there is a problem in those areas.
- The bar graph for battery-state-of-charge is on LCD screen. If the battery is discharged to lift-interrupt, the battery indicator symbol will also be flashing. If a battery of the wrong voltage has been installed, the Wrench light symbol will also be flashing. Have these problems corrected before attempting operation.

Turn the key or keyless switch to the **OFF** position. The following display sequence will occur:

Display Panel Features

- Display panel shows the hourmeter hours for the truck and hydraulic pump motors for five seconds. See **Figure 13**.

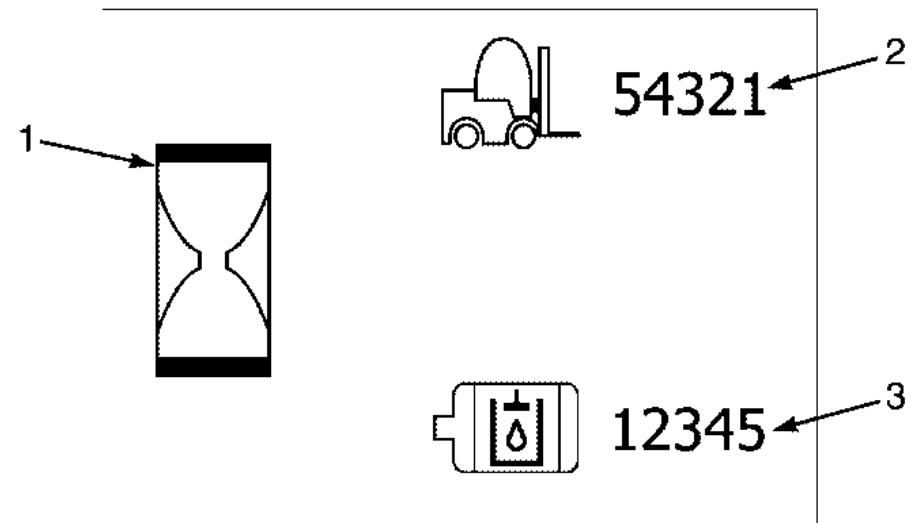

BO190382

1. HOURMETER ICON
2. TRUCK HOURS
3. HYDRAULIC PUMP MOTOR HOURS

Figure 13. Hourmeter Display at System Shutoff



Display Panel Features

HYSTER

Normal Sequence of Operation - Display Panel With Options

Following is the normal sequence that occurs after the operator is on the seat with the battery connected:

NOTE: If the password or operator check features are not enabled, the *Operator Screen* will appear after the key or keyless switch is moved to the **ON** position.

- After the key or keyless switch is moved to the **ON** position, the *Password Screen* will be on the LCD screen if this function is enabled.
- After password is correctly entered, or if it is disabled, the first item of the Operator Checklist will be on the LCD screen if this function is enabled.
- After Checklist is complete, or if it is disabled, the LCD screen will display the *Operator Screen* and the icons shown in **Figure 12** and **Table 3** will appear on the LCD

screen. After 10 seconds, the seat belt, low brake fluid, service due (if enabled), motor temperature icons, and low hydraulic fluid (if enabled) will no longer be illuminated and will illuminate again only if there is a problem in those areas.

- The last Performance Mode operation will be on the LCD screen as MODE #___. The bar graph for battery-state-of charge is also on LCD screen. If the battery is discharged to lift-interrupt, the battery indicator symbol will also be flashing. If a battery of the wrong voltage has been installed, the Wrench symbol will also be flashing. Correct these problems before attempting normal operation.

Turn the key or keyless switch to the **OFF** position. The following display sequence will occur:

- Display panel shows the hourmeter hours for the truck and hydraulic pump motors. See **Figure 13**.





HYSTER

Display Panel Features

Table 4. Auxiliary Control Levers

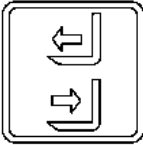
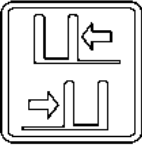
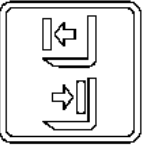
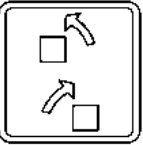
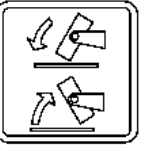
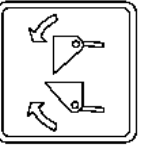
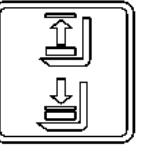
Function The control levers will be arranged in the following order from left to right.	Direction of Movement	
	Load or Equipment	Control Lever
1. REACH	Retract/Extend	Backward/Forward
2. SIDESHIFT	Right/Left	Backward/Forward
3. PUSH-PULL	Backward/Forward	Backward/Forward
4. ROTATE	Clockwise/Counterclockwise	Backward/Forward
5. UPENDER	Up/Down	Backward/Forward
6. SCOOP	Up/Down	Backward/Forward
7. LOAD STABILIZER	Down (Clamp)/Up (Release)	Backward/Forward
8. SWING (FORKS)	Right/Left	Backward/Forward
9. FORK SPREAD	Together/Apart	Backward/Forward
10. CLAMP	Clamp/Release	Backward/Forward

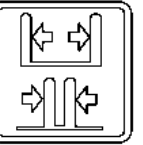
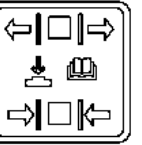
1	2	3	4	5	6	7	8	9	10
									

BO190744

Operating Procedures

HYSTER

Operating Procedures

General

Know Your Lift Truck

WARNING

ALWAYS make sure the parking brake is fully applied before leaving the lift truck. If the parking brake is not applied when the operator gets out of the seat or turns the lift truck OFF, an alarm will sound for 60 seconds. If the lift truck is left on a grade, without the parking brake fully applied, the lift truck will freewheel down the grade, possibly causing injury or property damage.

The fork lift truck is designed to pick up and move materials. The basic lift truck has a lift mechanism with forks on the front to engage the load. The lift mechanism lifts the load so that it can be moved and stacked.

In order to understand how the fork lift truck can pick up a load, you must first know some basic things about the lift truck.

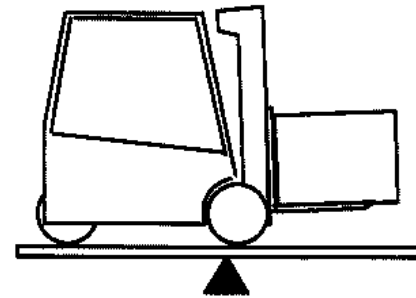

BO190532

The lift truck is based on the principle of two weights balanced on opposite sides of a pivot (fulcrum). This is the same principle used for a seesaw.

In order for this principle to work for a lift truck, the load on the forks must be balanced by the weight of the lift truck. The location of the center of gravity of both the truck and the load is also a factor.

This basic principle is used for picking up a load. The ability of the lift truck to handle a load is discussed in terms of center of gravity and both forward and side stability.

HYSTER

Operating Procedures

Stability and Center of Gravity

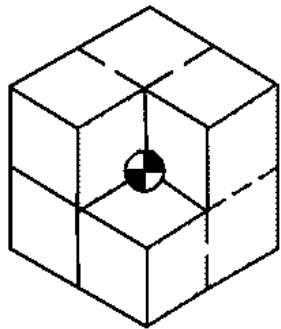

The center of gravity (CG) of any object is the single point about which the object is balanced in all directions. Every object has a CG. When the lift truck picks up a load, the truck and load have a new combined CG. The stability of the lift truck is determined by the location of its CG, or if the truck is loaded, the combined CG.

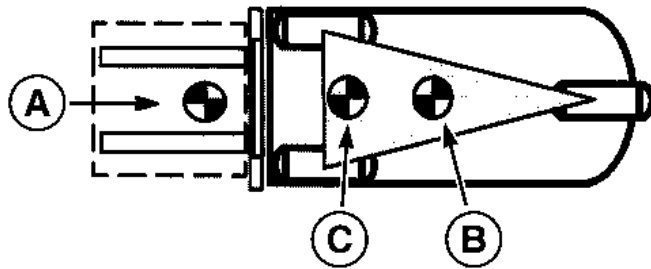

BO190533

A. CG LOAD B. CG TRUCK C. COMBINED CG

The lift truck has moving parts and therefore has a CG that moves. The CG moves forward and back as the mast is tilted forward and back. The CG moves up and down as mast moves up and down. The CG moves left and right as the traverse frame moves left and right.

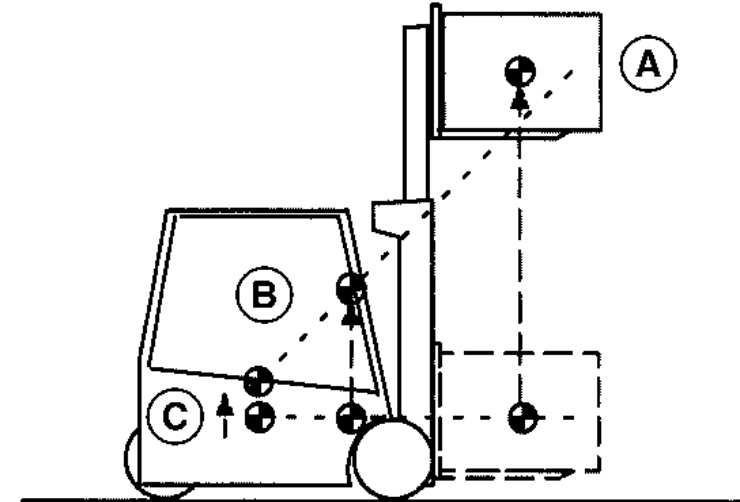

BO190534

A. CG LOAD B. COMBINED CG C. CG TRUCK

The center of gravity, and therefore the stability of the loaded lift truck, is affected by a number of factors, such as size, weight, shape, and position of the load; the height to which the load is raised; tire pressure; and the dynamic forces created when the truck is moving.

These dynamic forces are caused by things like acceleration, braking, turning, and operating on uneven surfaces or on an incline. These factors must be considered when traveling with an unloaded truck, as well, **because an unloaded truck will tip over to the side easier** than a loaded truck with its load in the lowered position.



Operating Procedures

HYSTER

In order for the lift truck to be stable, not tip over forward or to the side, the CG must stay within the area of the lift truck represented by a triangle drawn between the drive wheels and the pivot of the steering axle.

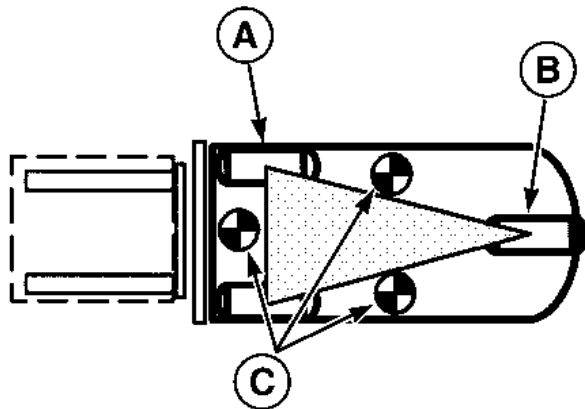

BO190564

- A. DRIVE AXLE
- B. STEERING AXLE
- C. CG - TRUCK WILL TIP OVER

If the CG moves forward of the drive axle, the lift truck will tip forward. If the CG moves outside of the line represented by the lines drawn between the drive wheels and the steering axle pivot, the lift truck will tip to that side.

Capacity (Weight and Load Center)

The capacity of the lift truck is shown on the Nameplate. The capacity is listed in terms of weight and load center.

The weight is specified in kilograms and pounds. The load center is specified in millimeters and inches. The capacity is the maximum load that the lift truck can handle for the load condition shown on the Nameplate.

! Trained Operators and Mechanics only

Read Operating Manual on seat or in operators compartment.

Failure to follow operating, inspection, and maintenance instructions can cause serious injury or death!

CAPACITY WITH MAST VERTICAL AND EQUIPPED AS SHOWN

HYSTER Lift Truck Model
Year of Manufacture

Serial No. Nominal Capacity kg

Attachment Volts

Truck Wt. Less Battery kg

Truck Wt. Max Battery kg

Allowable Battery Wt. kg to kg

Tread Width mm BackTilt Degrees

Tire Size Pressure Front Rear

MAXIMUM CAPACITY	Load Center		
	Load Height Dim. A	Dim. B	Dim. C
kg	mm	mm	mm
kg	mm	mm	mm

HO190942

The load center of a load is determined by the location of its center of gravity. The load center is measured from the front face of the forks, or the load face of an attachment, to the center of gravity of the load. Both the vertical and horizontal load centers are specified on the Nameplate.



HYSTER

Operating Procedures

Loads should be transported while centered on the center-line of the lift truck. The operator must know whether or not a load is within the maximum capacity of the lift truck before the load is handled.

Impact Sensor

The lift trucks covered in this **Operating Manual** may be equipped with an optional impact sensor that can be enabled or disabled by a service technician or supervisor. The impact sensor will sense when the lift truck has hit an object, and will cause the lift truck to shutdown. There are two types of impact that the Vehicle System Manager (VSM) recognizes: soft impact and hard impact.

The data parameters that determine whether an impact is a soft or hard one are entered into the lift truck's VSM by personnel with a service or supervisor password (see **Operator Passwords** in this section).

If the impact sensor option is enabled and an impact has been detected, then lift truck will shut down once the Impact Shutdown Timer has expired (range is from 0 to 30 seconds). During this time an alarm will sound and the Impact Detection icon will be displayed on the LCD screen. If the time is set to 0 seconds, the lift truck will shut down right after the impact is detected and no alarm will sound.

The Impact Shutdown Timer and other Impact related setup parameters can be set by either a service technician or supervisor.

The truck can be configured to completely shut down after an impact, which will include the electro-hydraulic functions. If a load is in the raised position and needs to be lowered, see **Load Handling, Emergency Load Lowering** and **Figure 21**.

Once shutdown, the lift truck cannot move until the impact sensor is reset by a supervisor or service technician. The Impact Detection icon will be displayed on the LCD screen any time the accelerator pedal is depressed (or hydraulic lever is moved, if configured to shut the truck completely down) while the truck is shut down.

Operating Procedures

HYSTER

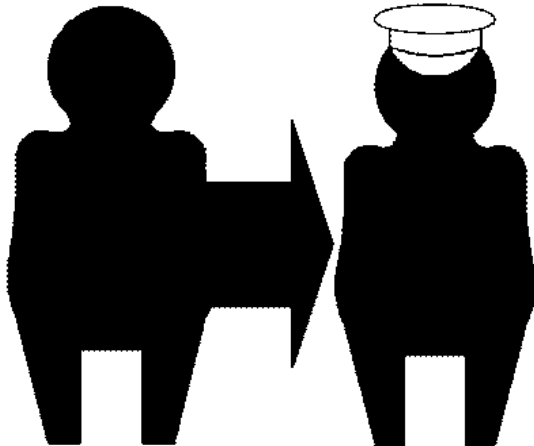

BO190745

Figure 14. Impact Detected Icon

To clear messages and reset truck to normal operation, an Impact Reset must be performed by either a service technician or supervisor. See **User Interface - Supervisor 2200 SRM 1335** or **User Interface - Service Technician 2200 SRM 1336** for procedures.

Cabin Heater

⚠ WARNING

Safety instructions must be followed or property damage and/or personal injury may occur.

SAFETY INSTRUCTIONS

- The cabin heater must not be covered in any way.
- DO NOT place objects on the cabin heater and DO NOT block air ducts.
- DO NOT insert any objects into the cabin heater.
- During heater operation, the outside cover will get hot.
- If the cabin heater does not work normally, it should be immediately taken out of service and the problem corrected.
- The cabin heater may not be modified from its original design.

The lift truck covered in this manual may be equipped with an optional Cabin Heater. The Cabin Heater is a bolt-on accessory that consists of the Cabin Heater, wiring harness, primary and secondary air filters, heater control unit, and necessary hardware.

At lift truck startup, the display on the control unit shows current operating parameters. The display shows in sequence: program version, followed by configuration and operating voltage.



HYSTER

Operating Procedures

Choice of temperature display settings is shown in the startup sequence together with current operating parameters. C0 indicates Celsius degrees and F0 indicates Fahrenheit degrees. The setting may be altered by pressing either the TEMP + or – button during start up sequence. The new setting is displayed in blinking until the choice is confirmed by pressing the ON button (within 2 seconds). The chosen setting will be stored and preserved even though the heater may be disconnected from the battery.

After the operating parameters have been shown or adjusted, the cabin heater enters standby mode. This is indicated by a green dot in the control unit display. The cabin heater is now ready for use.

See **Figure 15** and **Table 5** for a description of operation for the cabin heater.

Operating Procedures

HYSTER

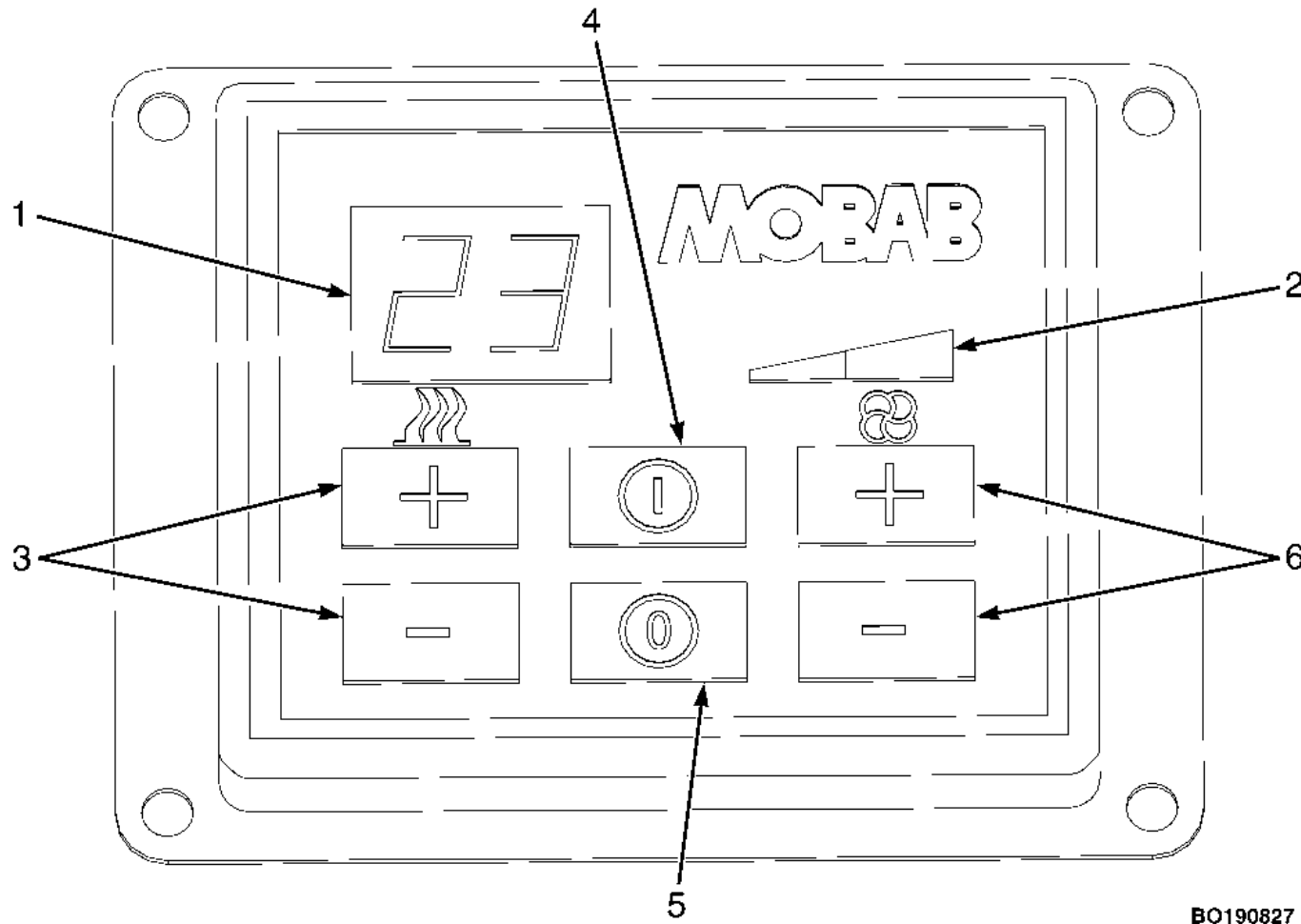

BO190827

Figure 15. Cabin Heater Operation



HYSTER

Operating Procedures

Table 5. Cabin Heater Operation

Item No.	Item Description	Description of Operation
1	Display	Displays requested temperature, operating parameters, and error messages.
2	Fan Speed Indicator	Displays current fan speed selected by operator.
3	Temperature Adjustment	Press + to increase temperature or – to decrease temperature. LO indicates that all heat is turned off. HI indicates that full heating power is turned on.
4	ON Button	Press this button to start the cabin heater. The fan starts and the requested temperature is shown in the display.
5	OFF Button	Press this key to turn off the cabin heater. The fan speed and requested temperature are stored. Standby mode is indicated by a green dot in the display.
6	Fan Speed Adjustment	Press + to increase or – to decrease the fan speed. If risk of overheating should occur, the fan speed will increase automatically.

Inspection Before Operation

 **WARNING**

Report damage or faulty operation immediately. Do not operate a damaged or defective lift truck. A lift truck will only do its job when it is in proper working order. If repairs are required, install a tag in the operator's area stating **DO NOT OPERATE** and remove the key from the key switch.

See **Checks and Inspection Procedures** in the **Maintenance Section** of this manual for detailed instructions. Also refer to **Table 1** for operation and description of controls.



Operating Procedures

HYSTER



Checks With the Key or Keyless Switch OFF

Inspect the lift truck before use and every eight hours or daily as described in the **Maintenance** section of this **Operating Manual**.

Before using the lift truck, make the following checks:

- Oil level in the hydraulic tank.
- Electrolyte level and specific gravity of the battery.
- Battery weight is within the range of battery weights on the Nameplate.
- Correct spacers are installed to limit horizontal battery movement.
- Condition of forks, carriage, chains, mast, and overhead guard.
- Leaks from the hydraulic system.
- Condition of wheels and tires.
- Seat belt fastens correctly.
- Seat is securely fastened to the battery cover.

- Battery cover is securely latched.

Operator Passwords

The lift trucks covered in this manual have an optional password feature.

The Operator Passwords are a series of five numbers. Each of the five number digits can be the numbers 1 through 5. If enabled, the password number series must be entered into the memory by a technician or a supervisor and assigned to an operator. Remember the password. If password is lost, contact your supervisor or a service technician. Supervisor Level password can be used to add, delete, or edit Operator Passwords.

After the five-digit password has been entered, press the enter button (*) and the system will check the password against the currently stored password list on the truck. If less than five digits are entered, pressing the enter button (*) will have no effect. If more than five digits are entered, the system will only use the last five digits entered. For example, if 123453 is entered, the LCD screen will only show 23453 as the currently entered password.

If the password is valid, the LCD screen moves onto the *Operator Screen* and the truck power can be turned on. If

HYSTER

Operating Procedures

the password is not valid, the *Invalid Password Screen* will appear for up to five seconds and the truck power cannot be turned on. The operator can re-enter the password again before or after the five seconds have elapsed.

If the password is entered again before the five seconds are over, the *Invalid Password Screen* will disappear and the *Enter Password Screen* will reappear. See **Figure 16**.

There are three password types used on these trucks:

- **Operator:** Allows operator to operate lift truck.
- **Supervisor:** Same rights as the Service Level password, except Supervisor Level password cannot add, change, or delete Service Level passwords.
- **Service:** Has all rights assigned to Operator and Supervisor passwords. Can add, edit, and delete Operator, Supervisor, and Service passwords and view all truck diagnostic information. Allows access to truck service parameters within preset limits. On trucks with hood switch option, allows starting truck with hood open.

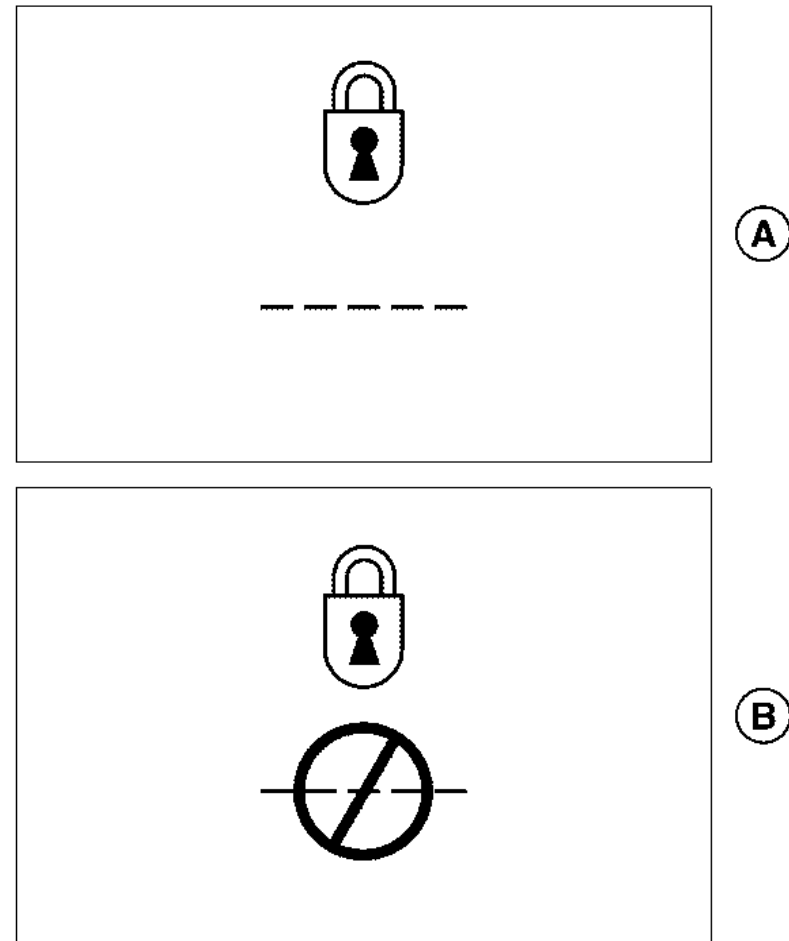

BO190384

Figure 16. Operator Password Screens



Operating Procedures

HYSTER



Legend for Figure 16

- A. ENTER PASSWORD SCREEN
- B. INVALID PASSWORD SCREEN

Operator Checklist

If your lift truck is equipped with the optional operator checklist, it can be enabled or disabled by a supervisor or service technician. See **Table 6**.

Table 6. Operator Checklist Icon Definitions

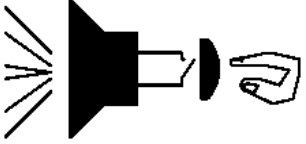
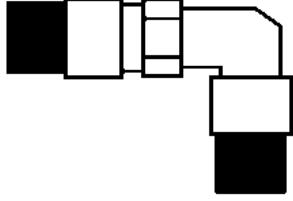
Icon	Definition
	Check Parking Brake
 <p>BO190538</p>	Check Fuses
 <p>BO190553</p>	Check Horn
 <p>BO190539</p>	Check Hoses



HYSTER

Operating Procedures

Table 6. Operator Checklist Icon Definitions (Continued)





Icon	Definition
 BO190540	Check Hydraulics
 BO190541	Check Mast
 BO190542	Check for Leaks

Table 6. Operator Checklist Icon Definitions (Continued)

Icon	Definition
 BO190543	Check Operator Restraint
 BO190543	Check Pedal Movement
 BO190544	Check Service Brake

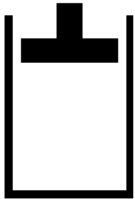
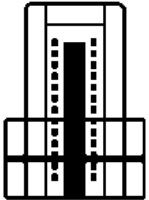
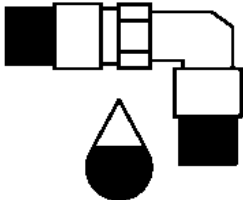
The operator checklist will appear on the LCD screen when the lift truck is powered **ON** and the correct password is entered, unless this operator satisfactorily completed the

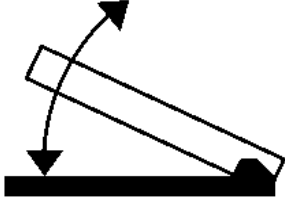

Operating Procedures

HYSTER

checklist less than 8 hours earlier. If the password function is not activated, the operator checklist will appear after lift truck is powered **ON** and the checklist has not been satisfactorily completed within the last 8 hours.

The operator checklist can store a maximum of 30 items. Each item includes a graphic representation of a system or component the operator is to check. The operator is instructed to press the Enter (*) button to select the check mark (**YES** response) or the Pound button to select the X (**NO** response) on the LCD screen. See **Table 1** and **Table 2**.

Selecting the check mark indicates that the current item in the checklist is operating properly. Selecting the X indicates a problem or issue with the current item in the checklist. See **Figure 17**. After the operator has provided an answer, the screen will move onto the next item in the checklist. The process repeats itself until all items in the checklist have been answered. All responses to items in the checklist are kept in the Operator Checklist Log, which can only be accessed by personnel with a supervisor or service technician password.

Once the checklist has been completed and all items were answered with a check mark (**YES** response), the lift truck

operation is enabled. If any checklist item is answered with an X (**NO** response), the maintenance due icon on the *Operating Screen* will flash repeatedly. See **Figure 12** and **Table 3**.

If any item on the checklist is marked with an X (**NO**), the maximum truck speed will be reduced by 50%. This condition can only be changed if the checklist is redone and every item is checked ✓ (**YES**) in the checklist. Alternatively, an authorized supervisor or service technician can turn off the checklist feature which will restore full truck performance.

HYSTER

Operating Procedures

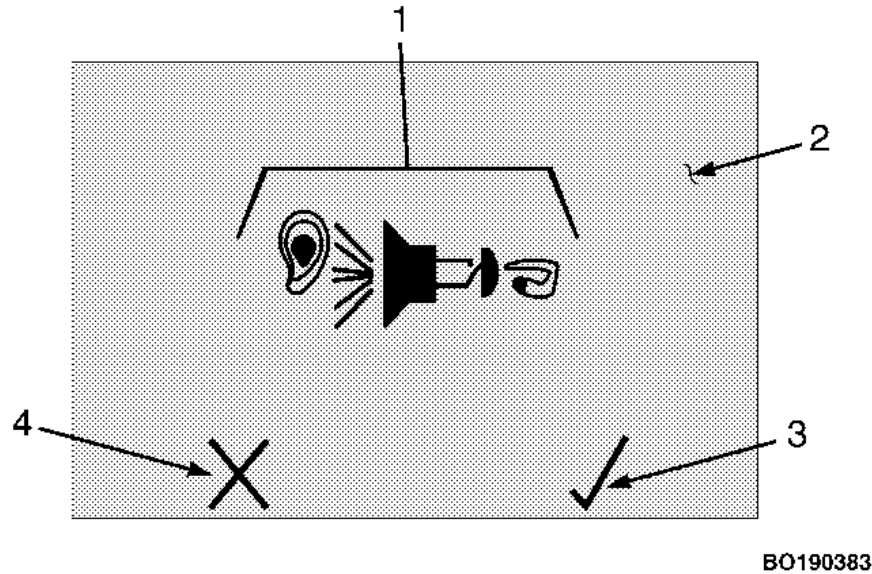

BO190383

1. ITEM OR COMPONENT BEING CHECKED
2. LCD SCREEN
3. CHECK MARK (* KEY)
4. X MARK (# KEY)

Figure 17. Operator Checklist Screen

Mounting and Dismounting

WARNING

To avoid serious injury when entering or exiting the lift truck, **ALWAYS USE 3 POINTS OF CONTACT. Maintain contact simultaneously with two hands and one foot or**

with two feet and one hand while climbing on or off the lift truck.

Place feet carefully. Always face the lift truck when climbing on or off. Use added care when surfaces are slippery. Keep hands free of any obstacles such as food, beverages, or tools.

If equipped, be sure cab door is secured in the closed position or removed before starting lift truck operations.

Start-Up Procedure - SRO Circuit

Lift Trucks with Software Versions Less than 4.32

The lift trucks covered in this manual are equipped with a **Static Return to OFF (SRO)** circuit that prevents travel of the lift truck if the starting sequence is not correct. The function of the SRO circuit is to make sure the operator is in the correct position to operator the controls before the lift truck will operate. The starting sequence:

1. Sit on the seat to close seat switch. Check to ensure all operator controls, traction and hydraulic, are in the neutral position. If a control is not in a neutral position, it must be returned to neutral and remain in the neutral position for 0.1 second before starting the lift truck. Turn the key or keyless switch to the **ON** position.



Operating Procedures

HYSTER

2. Select the direction of travel and push the accelerator or push the MONOTROL® pedal.

If **Step 2** is done before **Step 1** and the lift truck moves, the SRO function is not operating correctly. The sequence within Step 1 is not important. The lift truck must not be operated if the SRO circuit does not function correctly. If the SRO circuit does not operator correctly, have the Master Controller Checked by authorized service technician.

When you want the lift truck to travel in the Forward or Reverse direction:

1. Make sure a charged battery of the correct voltage is installed and connected.
2. Sit on the seat to close seat switch and turn key or keyless switch to the **ON** position.
3. Release the parking brake.
4. Select the direction of travel using the MONOTROL® pedal or the optional direction control switch. See **Figure 8**, **Figure 9**, and **Table 1**.
5. Push the MONOTROL® or accelerator pedal for acceleration.

Lift Trucks with Software Versions 4.32 and Greater

The lift trucks covered in this manual are equipped with a **Static Return to OFF (SRO)** circuit that prevents travel of the lift truck if the starting sequence is not correct. The function of the SRO circuit is to make sure the operator is in the correct position before the lift truck will operate.

For standard lift trucks, follow this starting procedure:

1. Make sure a charge battery of the correct voltage is installed and connected.
2. Sit on the seat to close seat switch. Check to ensure all operator controls, traction and hydraulic, are in the neutral position. If a control is not in the neutral position, it must be returned to neutral position before starting the lift truck.
3. Turn the key or keyless switch to the **ON** position.
4. Perform one of the following actions:
 - a. For lift trucks with manual parking brake, release the parking brake.
 - b. For lift trucks with automatic parking brake, press the service brake pedal.



HYSTER

Operating Procedures

5. Select the direction of travel using the MONOTROL® pedal or the optional direction control switch. See **Figure 8**, **Figure 9**, and **Table 1**.

6. Push the MONOTROL® or accelerator pedal for acceleration.

If Step 5 is done before Step 1 through Step 4 and the lift truck moves, the SRO function is not operating correctly. The lift truck must not be operated if the SRO circuit does not function correctly. If the SRO circuit does not operate correctly, have the Master Controller checked by authorized service technician.

For lift trucks equipped with the Optional Operator Presence System (OPS), follow this starting procedure:

1. Make sure a charged battery of the correct voltage is installed and connected.
2. Sit on the seat to close seat switch. Fasten seat belt to close belt switch. Check to ensure all operator controls, traction and hydraulic, are in neutral position. If a control is not in the neutral position, it must be returned to neutral position before starting the lift truck.
3. Turn the key or keyless switch to the **ON** position.

4. Perform one of the following actions:

- a. For lift trucks with manual parking brake, release the parking brake; if the parking brake was **NOT** set, recycle brake.
- b. For lift trucks with automatic parking brake, press the service brake pedal.

5. Select the direction of travel using the MONOTROL® pedal or the optional direction control switch. See **Figure 8**, **Figure 9**, and **Table 1**.

6. Push the MONOTROL® or accelerator pedal for acceleration.

Lift Truck Interlocks

Certain operator actions, if not performed correctly while operating the lift truck, will cause either the traction motor or hydraulic functions to become disabled.

DRIVE INTERLOCKS: The traction motor is enabled when the operator is in the seat (occupancy sensor), seat belt is fastened, a direction of travel is selected, and the parking brake is released.



Operating Procedures

HYSTER

The battery cover switch, or if lift truck is equipped with a battery gate switch, must indicate that the batteries are secure in the battery compartment.

If any of the above actions are not performed while operating the lift truck, the traction motor will be disabled. The LCD screen on the display panel will provide an icon indicating which action needs to be performed to enable the traction motor. Examples of this are "Seat Interlock" or "Parking Brake Interlock." See **Table 7**. Once the needed action is completed, the traction motor will be enabled and the operator can continue to drive the lift truck.

HYDRAULIC INTERLOCKS: The hydraulic functions are enabled when the operator is in the seat (occupancy sen-

sor), seat belt is fastened, and the battery cover switch, or if lift truck is equipped with a battery gate switch, indicates that the battery is secure in the battery compartment.



If any of the above actions are not performed while operating the lift truck, the hydraulic functions will be disabled. The LCD screen on the display panel will provide an icon to the operator indicating which action needs to be performed to enable hydraulic functions. Examples of this are "Seat Interlock" or "Battery Not Secure." See **Table 7**. Once the needed action is completed, the hydraulic function will be enabled and the operator can continue to load and unload material.



HYSTER

Operating Procedures

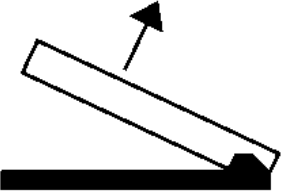
Table 7. Alert Screens/Interlock Notifications



Icon	Condition	Operator Action Required
 B0190545	Accelerator Pressed (SRO Not Satisfied).	Release The Accelerator Pedal.
	Standard OPS, Accelerator Pressed (SRO Not Satisfied).	Press Service Brake Pedal
	Equipped with Optional OPS, Accelerator Pressed (SRO Not Satisfied).	Apply Parking Brake



Operating Procedures

HYSTER

Table 7. Alert Screens/Interlock Notifications (Continued)



Icon	Condition	Operator Action Required
 BO190990	Hydraulic Function 1 Out of Neutral.	Release Hydraulic Function 1 Lever or Button.
 BO190991	Hydraulic Function 2 Out of Neutral, or Function 2 Button Out of Neutral.	Release Hydraulic Function 2 Lever or Button.



HYSTER

Operating Procedures

Table 7. Alert Screens/Interlock Notifications (Continued)



Icon	Condition	Operator Action Required
 BO190992	Hydraulic Function 3 Out of Neutral, or Function 3 Button Out of Neutral.	Release Hydraulic Function 3 Lever or Button.
 BO190993	Hydraulic Function 4 Out of Neutral, or Function 4 Button Out of Neutral.	Release Hydraulic Function 4 Lever or Button.



Operating Procedures

HYSTER

Table 7. Alert Screens/Interlock Notifications (Continued)

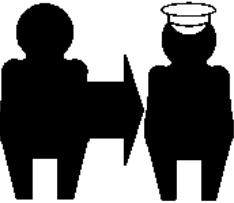



Icon	Condition	Operator Action Required
 BO190998	Direction Select in Neutral.	Take Lift Truck Out of Neutral by Pushing the Monotrol Pedal or Moving Direction Control Switch and Pushing Accelerator Pedal.
 BO190552	Operator out of the Seat or Seat Belt Switch Open.	Sit Fully in the Seat and Fasten Seat Belt.
 BO190546	Impact Detected.	Service Technician or Supervisor Password Must be Entered to Reset System.

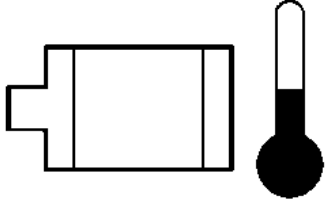

HYSTER

Operating Procedures

Table 7. Alert Screens/Interlock Notifications (Continued)



Icon	Condition	Operator Action Required
	Over Temperature.	Allow Motor(s) to Cool off, Then Recycle Key or Keyless Switch to Satisfy SRO.
 BO190547	Key Switch Not Detected in OFF Position.	Cycle the Key Switch.
	Park Brake Applied.	Release Park Brake.
	Battery is Not Secured.	Close Battery Gate/Hood Fully.



Operating Procedures

HYSTER

Table 7. Alert Screens/Interlock Notifications (Continued)

Icon	Condition	Operator Action Required
	Fault Has Been Detected.	Notify Service Technician to correct the Fault.
 <p data-bbox="353 970 465 994">BO190994</p>	Truck Disabled Due to E-Steer Controller.	Notify Service Technician to Correct the Fault.
 <p data-bbox="318 1311 430 1335">BO190995</p>	Truck Disabled Due to Right (Single) Traction Controller.	Notify Service Technician to Correct the Fault.



HYSTER

Operating Procedures

Table 7. Alert Screens/Interlock Notifications (Continued)

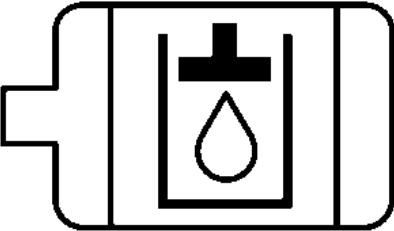
Icon	Condition	Operator Action Required
 <p>BO190996</p>	Truck Disabled Due to Left Traction Controller.	Notify Service Technician to Correct the Fault.
 <p>BO190997</p>	Truck Disabled Due to Pump Controller.	Notify Service Technician to Correct the Fault.

Operating Procedures

HYSTER



ON

Checks With the Key or Keyless Switch

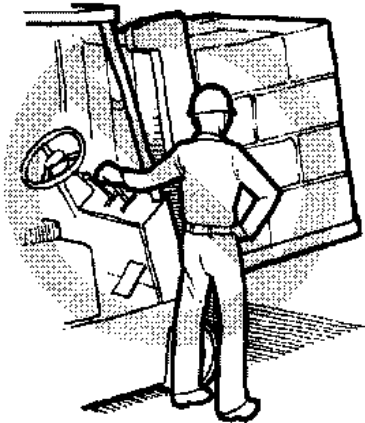

BO190535

Do not turn lift truck power on nor operate the lift truck, including any of its functions or attachments, from any place other than the designated operator's position.

The operator must be aware that the lift truck can tip over. There is a great risk that the operator or someone else can be killed or injured if trapped or hit by the truck as it tips over. The risk of

injury can be reduced if the operator stays on the truck. If the truck tips over do not jump off.

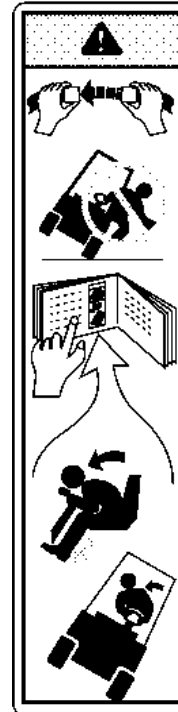

BO190113



WARNING

FASTEN SEAT BELT If Lift Truck Tips Over

- Do Not Jump – Stay On Truck
- Hold Firmly To Steering Wheel – Brace Feet – Lean Forward And Away From Impact

The seat belt is installed to help the operator stay on the truck if the lift truck tips over. IT CAN ONLY HELP IF IT IS FASTENED.

THE SEAT BELT AND HIP RESTRAINT BRACKET provide a means to help the operator keep the head and torso substantially within the confines of the truck frame and overhead guard if a tipover occurs. This protection system is intended to reduce the risk of the head and torso being trapped between the truck and the ground, but it cannot protect the operator against all possible injury in a tipover.

Make sure that the area around the lift truck is clear before making any operational checks. Be careful when making



HYSTER

Operating Procedures

the checks. If the lift truck is stationary during a check, apply the parking brake. Proceed carefully.

Check the operation of the following functions as described in the **Maintenance** section.

- Check the operation of the horn and indicator lights.
- Operate the lift, tilt, and auxiliary functions to check for correct operation of the mast, carriage, and attachments.
- Check the operation of the steering system.
- Check the operation of the MONOTROL® pedal or the directional control lever and the accelerator pedal.
- Check the operation of the service brakes and the park brake.
- Check that hood is securely latched.

Load Weighing Sensor

If the lift truck is equipped with the optional load weight sensor, it will display the weight of the load in either pounds or kilograms on the LCD screen. See **Figure 12** and **Table 3**. The unit of measure is preset by a service techni-

cian or a supervisor and can be changed by a service technician or supervisor.

The operator can access the load weight function by pressing the scroll forward or scroll backward button on the display panel until the *Calibrations Menu* appears. Press the #2 button to scroll up or the #3 button to scroll down to scroll through the menu selections within the *Calibrations Menu* until the Load Weight menu appears. Press the enter (*) button to enter the load weight menu.

To most accurately weigh a load, follow these instructions:

1. With a load on the forks, position the mast in a vertical position.
2. Lift the load 0.6 m (2 ft) off the ground, but if free-lift cylinder is present, not more than maximum free lift.
3. Lower the load 51 mm (2 in.). Stop lowering, wait 1 second, and read the load weight. This will be the most accurate weight. Waiting longer to read the load weight will reduce accuracy.

Set Load Weight to Zero

The operator can set the load weight to zero, when the no load weight displayed on the LCD screen with the forks/



Operating Procedures

HYSTER

attachment 0.6 m (2 ft) off the ground and is not within $\pm 2\%$ of truck capacity. Example: This is ± 45 kg (100 lb) for a 2268 kg (5000 lb) truck.

To set the Load Weight System to zero, perform the following procedures:

1. Turn lift truck power **ON**.
2. If lift truck is equipped with optional Operator Password feature, enter operator password to enter the main menu. See the section **Operator Passwords** for procedures.
3. If lift truck is equipped with optional Operator Checklist feature, fill out the checklist questions. See the section **Operator Checklist** for the procedures. After checklist is completed, the LCD screen will show the *Operator Screen*.
4. From the *Operator Screen*, press the scroll back (left arrow key) or scroll forward (right arrow key) to go to the *Calibrations Menu Screen*. See **Table 8**.
5. Press the enter (3) button to select the *Calibrations Menu*.
6. Press the #2 button to scroll up or the #3 button to scroll down until the Weight Icon appears on the LCD screen. See **Table 8**.

7. Press the enter button (*) to select the Load Weight-Set Zero feature.

8. With no load on the forks, position the mast in a vertical position. See **Table 8**.



9. Lift the empty forks/attachment 0.6 m (2 ft) off the ground but if free-lift cylinder is present, not more than maximum free lift. Then, lower the forks/attachment 51 mm (2 in.), wait 1 second, and IMMEDIATELY press the (*) key to set the zero point.

The Load Weight System is now set to zero.

HYSTER

Operating Procedures

Table 8. Set Load Weight to Zero

Icon	Definition
 BO190551	Calibration Main Menu
 BO190550	Weight
 BM081095	Position Empty Forks at Load Weight Height

Operating Techniques

⚠ WARNING

The seat belt is installed to help the operator stay on the truck if the lift truck tips over. It can only help if it is fastened. Before operating the lift truck, fasten your seat belt.

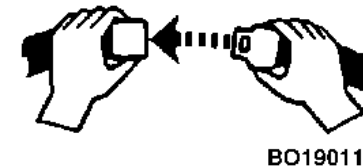

⚠ WARNING

The lift truck can tip over during operation. If you have not read the warning page in the front of this Operating Manual, do so now. As you study the following information about properly operating a lift truck, remember the warnings.

The hip restraint and seat belt help to keep the head and torso of the operator substantially within the confines of the truck frame and operator compartment if a tipover occurs. This system is intended to reduce the risk of the head and torso being trapped between the truck and the ground, but



Operating Procedures

HYSTER

it can not protect the operator against all possible injuries in a tipover.

Basic Operating Procedures

Many people make the mistake of thinking that operating a lift truck is the same as driving an automobile. This is not true. It is true that some lift truck operating procedures are as simple and obvious as driving the family automobile. (Example: Look where you are going, start and stop smoothly, etc.) But a lift truck is a special machine designed to do a much different job than an automobile. Because of the close areas in which a lift truck operates and its other operating characteristics, like rear wheel steering and tailswing, every operator must receive additional training, even if they have a license to drive an automobile.

The following discussion lists basic procedures applicable to lift truck operation.

1. Authorized and Trained Operator Only - This means the operator must be trained to drive the lift truck and it means that the operator must thoroughly understand the procedures for lift truck operation. It also means that a qualified person experienced in lift truck operation must guide the operator through several driving and load han-

dling operations before the operator attempts to operate the lift truck alone. A basic education in proper driving and load handling techniques is absolutely necessary to prepare the new operator for proper defensive driving and to expect the unexpected.

2. Hazardous Area - Operate the lift truck only in areas that have been approved for lift truck operation.



HO190472

Certain areas contain hazardous flammable gases, liquid, dust, fibers, or other materials. Lift trucks that are operated in these areas must have special fire safety approval.

These areas must be designated to show the type of lift truck approval required for operation in the area. Changes to special equipment or poor maintenance can make the lift truck lose its special approval.

WARNING

This lift truck is designed for handling materials. A lift truck is not designed to lift people. Do not use a lift truck to lift people unless it has been determined that there is no other practical option (scaffolds, elevated

HYSTER

Operating Procedures

work platforms, aerial baskets, etc.) to perform the needed work.

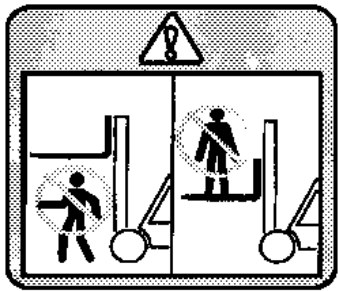

BO190117

If a lift truck is used to elevate a worker, a safety platform must be attached to the forks and carriage. The platform must have a solid floor with a surface to prevent the feet of the worker from slipping, hand rail, toe board, and a screen or shield at least 2 m (7 ft) high

between the people on the platform and the lift mechanism.

The combined weight of the platform, load, and personnel is not to exceed one-half of the capacity as indicated on the nameplate of the truck on which the platform is used.

Before anyone is allowed in the platform, lift and lower the mast slowly with the platform in place to make sure the mast functions properly. Apply the parking brake. Do not travel with people in the platform. The operator must remain at the controls. Watch for overhead obstructions.

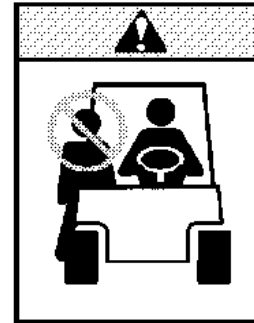

BO190116

3. No Riders - A lift truck is built for only one person -- the operator. It is dangerous for anyone to ride on the forks or anywhere else on the lift truck.

4. Adjust Seat.

Seat Position Adjustment (Swivel Seat)

- The seat swivels 12 degrees to the right to allow the operator a more ergonomic position when driving in reverse.
- The seat swivels 5 degrees to the left to allow an easier exit of the truck.
- The neutral position is shown in **Figure 18**.

Seat Position Adjustment (Full Suspension, High Back Seat)

NOTE: The lift trucks covered in this **Operating Manual** may be equipped with an optional full suspension, high back seat with adjustable headrest and lumbar support.



Operating Procedures

HYSTER

- To adjust the lumbar support, move the adjustment wheel to increase or decrease lumbar support to desired position. See **Figure 19**.
- To adjust the headrest, position hands under the headrest and lift headrest up until desired position is reached. See **Figure 19**.

Seat Adjustment for Operator Weight



CAUTION

A major cause for high Whole Body Vibration is caused by the operator not adjusting the seat to his/her weight.

NOTE: It is important to adjust the weight setting for each operator.

NOTE: The seat is designed for a maximum weight of 135 kg (298 lb).

- The target is for the "ride indicator" to fall between the arrows when the operator sits upright in the seat with the feet positioned on the pedals. This ensures that the operator is set at the midpoint of the 80 mm (3.5 in.) suspension.
- The handle can be turned as shown to increase or decrease the weight resistance, pull handle out before turning. As the handle is turned the "stiffness" of the suspension can be felt to increase or decrease depending on which way the handle is turned.
- The measured vibration levels measured to EN13059 are noted in the front of this manual in the **Foreword** section.

HYSTER

Operating Procedures

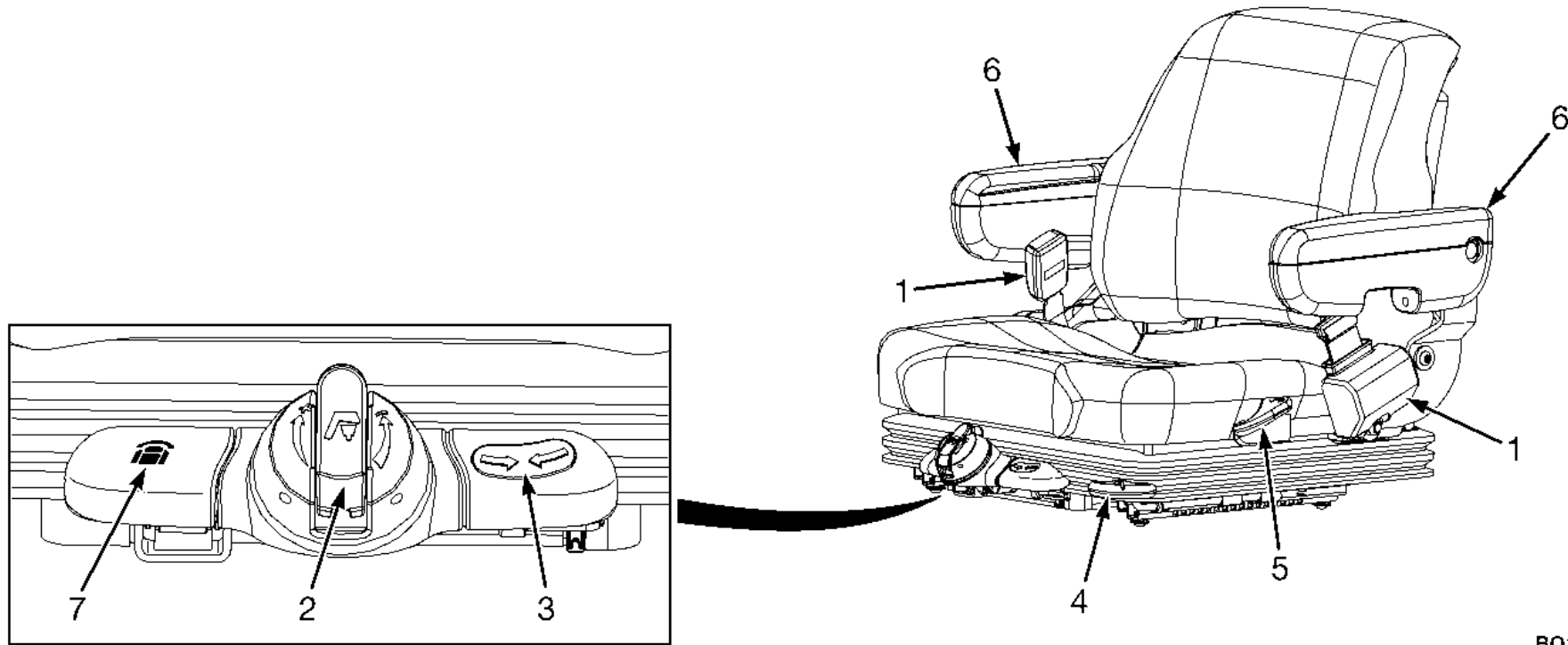

BO190622

1. SEAT BELT
2. WEIGHT ADJUSTMENT KNOB
3. RIDE POSITION INDICATOR
4. FORWARD/BACKWARD ADJUSTMENT LEVER

5. BACKREST ANGLE ADJUSTMENT LEVER
6. ARMREST
7. SWIVEL LATCH RELEASE LEVER

Figure 18. Seat Adjustment (Full Suspension and Swivel Seats)

Operating Procedures

HYSTER

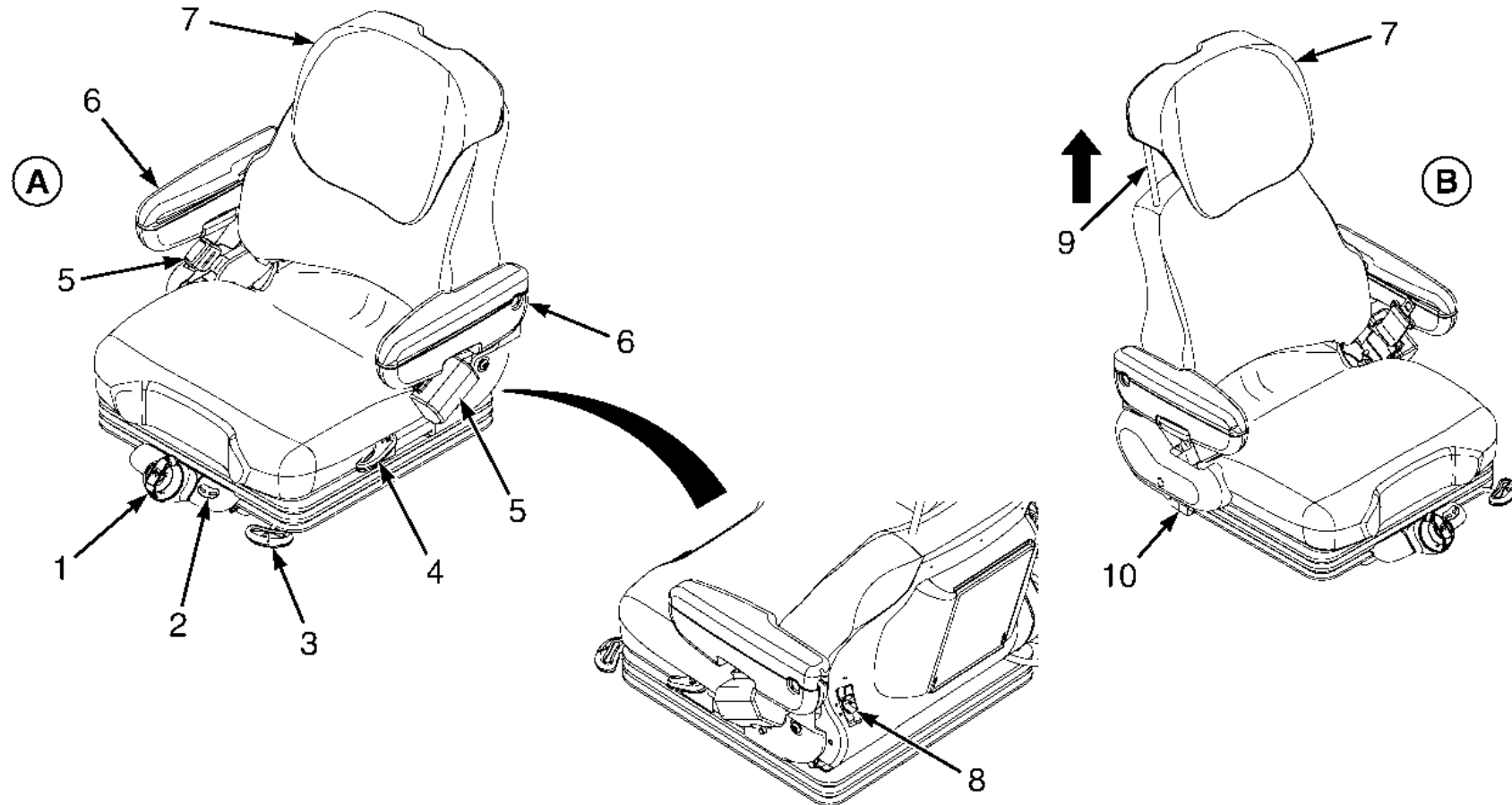

BO190888

Figure 19. Seat Adjustment (Full Suspension, High Back Seat)



HYSTER

Operating Procedures

Legend for Figure 19

- | | |
|---|---|
| <p>A. HEADREST IN NEUTRAL POSITION</p> <ol style="list-style-type: none"> 1. WEIGHT ADJUSTMENT KNOB 2. RIDE POSITION INDICATOR 3. FORWARD/BACKWARD ADJUSTMENT LEVER 4. BACKREST ANGLE ADJUSTMENT LEVER 5. SEAT BELT | <p>B. HEADREST FULLY EXTENDED</p> <ol style="list-style-type: none"> 6. ARMREST 7. ADJUSTABLE HEADREST 8. ADJUSTMENT WHEEL 9. HEADREST ADJUSTMENT ROD 10. SEAT ELECTRICAL CONNECTOR |
|---|---|

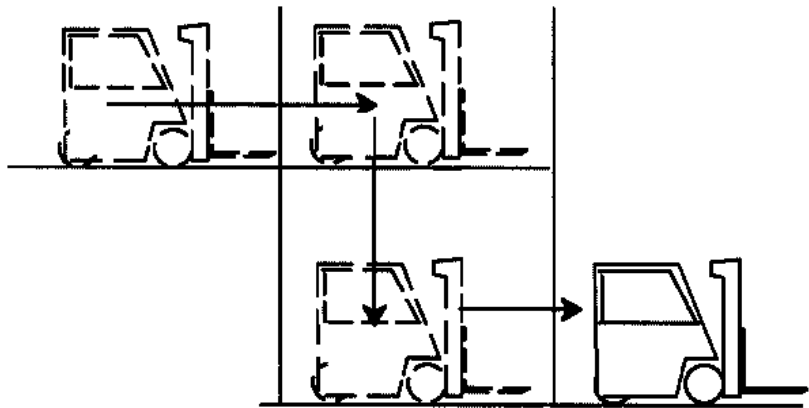

BO190536

5. Lifts - Do not drive a lift truck into a lift unless authorized to do so. Approach the lift slowly. After the lift is properly leveled, the lift truck must be centered so that the lift is balanced. When the lift truck is in the proper position in the lift, set the brakes, put the controls in **NEUTRAL**, and shut off the power. It is advisable that all other personnel leave the lift before the lift truck enters or leaves.

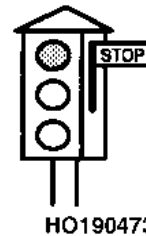

6. Drive Carefully - Observe traffic rules and be in full control of the lift truck at all times. Be completely familiar with all the driving and load handling techniques contained in this **Operating Manual**.

Driving and Direction Changes

These lift trucks can have either a MONOTROL pedal or a direction control switch with an accelerator pedal. If the lift truck has a MONOTROL pedal, push on the left side of the pedal to go **Forward**, or the right side of the pedal to go in **Reverse**.

If the lift truck has a direction control switch, push the top part of the switch to travel **Forward**. Push the bottom part of the switch to travel in **Reverse**. After direction of travel has been selected, push down on the accelerator pedal. See **Figure 8**, **Figure 9**, and **Table 1**.

Operating Procedures

HYSTER

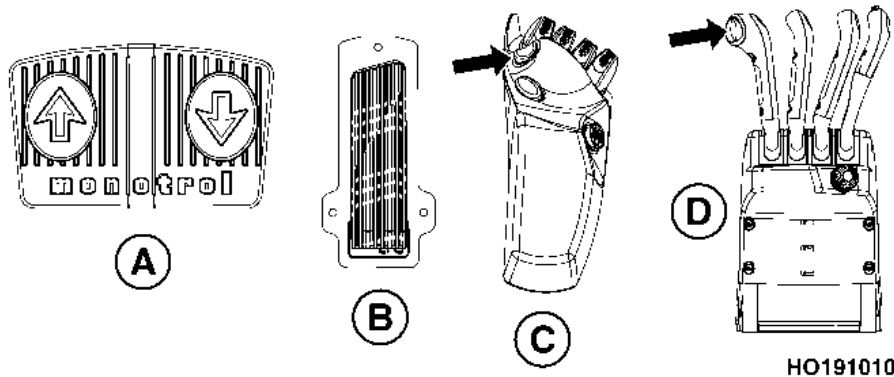

- A. MONOTROL® PEDAL
- B. ACCELERATOR PEDAL
- C. DIRECTION CONTROL SWITCH - E-HYDRAULIC CONTROLS
- D. DIRECTION CONTROL SWITCH - MANUAL CONTROLS

⚠ WARNING

DO NOT select the travel direction if the accelerator is depressed. The lift truck will move rapidly and can cause damage or injury.

To move the lift truck, select a direction, release the parking brake and push down on the accelerator pedal.

If the lift truck is equipped with a MONOTROL® pedal, place foot on the service brake pedal and release the parking brake. Select the direction of travel by slowly depressing on either the left or right side of the MONOTROL® pedal. Remove foot from service brake pedal. Continue

pressing the MONOTROL® pedal to move the lift truck in the selected direction.

⚠ WARNING

Changing the direction of travel to reverse when the lift truck is traveling fast can cause the load to come off the forks and cause damage to equipment and serious injury to personnel.

The operator can change the direction of travel while the lift truck is moving by moving the foot to the other side of the MONOTROL® pedal, or by moving the direction control switch for travel in the opposite direction. This action uses the motor for braking and can take place at any travel speed.

The lift truck will come to a stop and then accelerate in the opposite direction, unless the MONOTROL® pedal or accelerator pedal is released. The braking action of the motor can be used to stop the lift truck. To stop the lift truck quickly, use the service brakes.

Steering (Turning)

Most operators can understand the need to be careful when handling loads. But some operators do not realize that a tipover can occur with an empty lift truck because



HYSTER

Operating Procedures

similar dynamic forces are present. In fact, the lift truck will actually tip over easier when empty, than when loaded with the load lowered. Rearward tilt, off-center loads and uneven ground will aggravate these conditions.

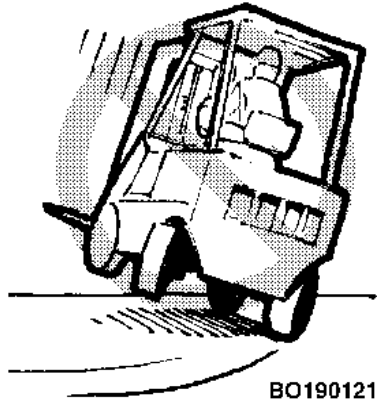

⚠ WARNING
TRAVEL SLOWLY WHEN TURNING. Lift trucks can tip over even at very slow speeds. The combination of speed and the sharpness of a turn can cause a tipover. A lift truck is less stable when the forks are elevated, with or without a load.

IF THE LIFT TRUCK TIPS OVER, DO NOT JUMP OFF! HOLD FIRMLY TO STEERING WHEEL, BRACE YOUR FEET, AND LEAN FORWARD AND AWAY FROM THE POINT OF IMPACT.

Because lift trucks are designed to work in a relatively small space, they can turn sharper than some other vehicles. Most lift trucks are steered by the rear wheels and the rear of the lift truck can move to the side very fast during a turn. This movement is called "tail swing". An operator

must be aware of tail swing and always check to make sure the tail swing area is clear before turning.

⚠ WARNING
Failure to observe the tail swing area when making a turn can injure or kill someone.

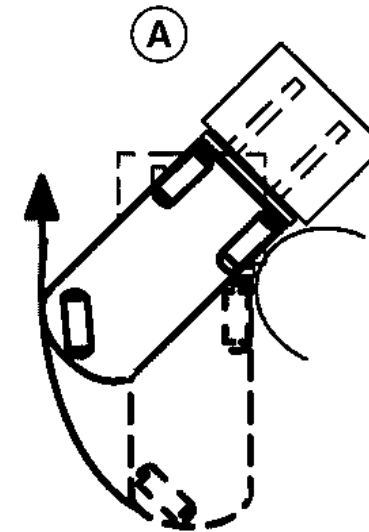

A. TAILSWING

BO190537

Operating Procedures

HYSTER

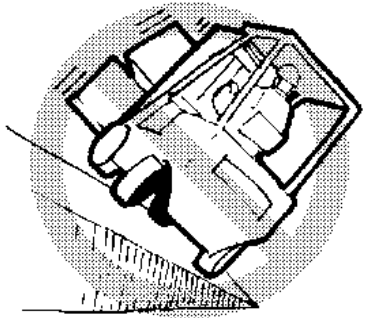

BO190123

Do not turn on an incline. To reduce the possibility of a tipover, a lift truck must not be driven across an incline.

When possible, keep both hands on the steering wheel. During most loading or unloading operations, the operator steers with the left hand.

The right hand is used to operate the lift, tilt, and attachment controls.

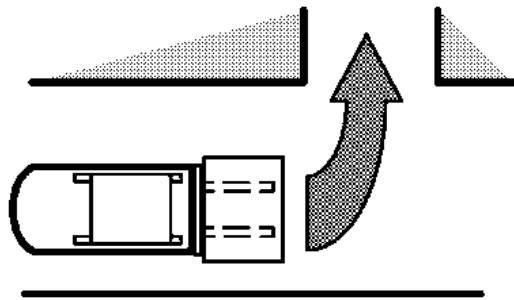

BO190125

When turning the lift truck from a wide aisle into a narrow aisle, start the turn as close to the opposite stock pile as tail swing will permit. This action permits the lift truck to enter the narrow aisle going straight ahead.

Synchronized Steering Control

This feature is only available on lift trucks Manufactured Before March, 2015 and equipped with the Synchronized Steering function, and is set by personnel with a supervisor or service technician level password.

This feature allows either the supervisor or service technician to adjust the position that the steering wheel will be in when the lift truck is traveling straight ahead.

The operator will notice that the steering wheel always returns to the same position when the lift truck starts to travel in a straight direction after completing a turn.

E-Steering Control

Lift trucks manufactured after February, 2015 are equipped with E-steering control. The features of E-steering control are set using supervisor or service technician level password.

This feature allows either the supervisor or service technician to adjust the position that the steering wheel will be in when the lift truck is traveling straight ahead. The operator will notice that the steering wheel always returns to the



HYSTER

Operating Procedures

same position when the lift truck start to travel in a straight direction after completing a turn.

The supervisor or service technical can also adjust the amount of effort required to turn the steering wheel when turning the lift truck. This improves the operator's ability to handle the lift truck and reduces operator fatigue.

A lift truck equipped with E-steering control produces less noise during steering functions and uses less energy to steer the lift truck.

Auto Power Off

If the lift truck goes through 15 minutes of inactivity, it will automatically power off, even if the operator is in the seat. To turn lift truck power **ON** again, turn the key or keyless switch to the **ON** position. If the key or keyless switch is in the **ON** position when the lift truck powers off, turn the key or keyless switch to the **OFF** position and then turn the key or keyless switch to the **ON** position.

If the lift truck is equipped with the Operator Password feature, the operator must re-enter his password. If the Operator Checklist feature is enabled, the operator will NOT have to redo the checklist items if the same operator re-applies power within one hour of Auto Power Off.

Standard Operator Presence System

WARNING

ALWAYS make sure the parking brake is fully applied before leaving the lift truck. If the operator leaves the lift truck without applying the parking brake, a seat activated switch will cut off all electrical and hydraulic power to the lift truck.

The lift trucks covered in this manual are equipped with an Operator Presence System (OPS). The OPS feature has an electrical sensor switch in the seat which senses the presence of the operator. The OPS is designed with slight delay in the seat switch to allow the operator to reposition himself without disabling all hydraulic and electrical functions.

The operator must be on the seat before turning the key or keyless switch **ON** to provide power to the lift truck. If the operator leaves the seat while the truck is moving, or does not apply the parking brake before getting off the seat, the seat switch will cut off power to the lift truck.



Operating Procedures

HYSTER

Lift Trucks with Software Versions Less than 4.32

If the lift truck is equipped with a direction control switch or MONOTROL® pedal and the operator leaves the seat without engaging the parking brake, the **N** indicator light on the LCD screen will illuminate regardless of the position of the direction control switch or MONOTROL®. When the operator returns to the seat, to resume travel, the indicator light will change from **N** to the direction of travel that the directions control switch or MONOTROL® pedal was in when the operator left the lift truck. The operator can resume travel by depressing the accelerator or MONOTROL® pedal. See **Figure 9** and **Table 1**.

If the operator leaves the seat, the hydraulic functions will stop and the mini-lever or manual lever will return to the neutral position. The operator must sit back down on the seat in order to continue hydraulic functions.

Lift Trucks with Software Versions 4.32 and Greater

If the lift truck is equipped with a direction control switch or MONOTROL® pedal and the operator leaves the seat without engaging the parking brake, the **N** indicator light on the LCD screen will illuminate regardless of the position of the direction control switch or MONOTROL® pedal. When the operator returns to the seat, the indicator light will change

from **N** to the direction of travel that the direction control switch or MONOTROL® pedal was in when the operator left the lift truck. To resume travel, if the lift truck is equipped with a manual parking brake, release the brake; if the lift truck is equipped with an automatic parking brake, press the service brake pedal. Then press the accelerator or MONOTROL® pedal.

Optional Operator Presence System

⚠ WARNING

ALWAYS make sure the parking brake is fully applied before leaving the lift truck. If the operator leaves the lift truck without applying the parking brake, a seat activated switch will cut off all electrical and hydraulic power to the lift truck.

The lift trucks covered in this manual are equipped with an Operator Presence System (OPS). The OPS feature has an electrical sensor switch in the seat which senses the presence of the operator. The OPS is designed with slight delay in the seat switch to allow the operator to reposition himself without disabling traction and most hydraulic functions.



HYSTER

Operating Procedures

The operator must be on the seat and the seat belt must be fastened before turning the key or keyless switch **ON** to provide power to the lift truck. If the operator leaves the seat while the truck is moving, or does not apply the parking brake before getting off the seat, the seat switch will cut off power to the lift truck.

For lift trucks equipped with a manual parking brake, when the operator returns to the seat, if it was not set, the parking brake must be applied and released.

Lift Trucks with Software Versions 4.32 and Greater

If the lift truck is equipped with a direction control switch or MONOTROL® pedal and the operator leaves the seat with-

out engaging the parking brake, the **N** indicator light on the LCD screen will illuminate regardless of the position of the direction control switch or MONOTROL® pedal. When the operator returns to the seat, the indicator light will change from **N** to the direction of travel that the direction control switch or MONOTROL® pedal was in when the operator left the lift truck. To resume travel, if the lift truck is equipped with a manual parking brake, release the brake; if the lift truck is equipped with an automatic parking brake, press the service brake pedal. Then press the accelerator or MONOTROL® pedal.



Operating Procedures

HYSTER

Automatic Parking Brake

The lift trucks covered in this **Operating Manual** may be equipped with an optional Automatic Parking Brake (APB). The APB will apply to the traction motor after the truck stops if the operator does any of the following actions:

- Leaves the seat.
- Turns the lift truck power to **OFF**.
- Takes his foot off the accelerator or MONOTROL® pedal, and leaves it off until the truck coasts to a stop.

To release the APB, the operator must follow the procedure below:

1. Sit in the seat.

2. Fasten the seat belt.
3. Turn the key or keyless switch to the **ON** position, if the lift truck power was turned OFF.
4. Press the service brake pedal, if the operator left the seat or if lift truck power was turned OFF.
5. Press the accelerator or MONOTROL® pedal.

If the lift truck loses power and has to be towed, there is a manual override handle that will disable the APB. The manual override handle is located underneath the floor mat and floor plate and mounted to the front bulkhead. To apply the manual override, remove the floor mat and floor plate and pull the handle up. See **Figure 20**.

HYSTER

Operating Procedures

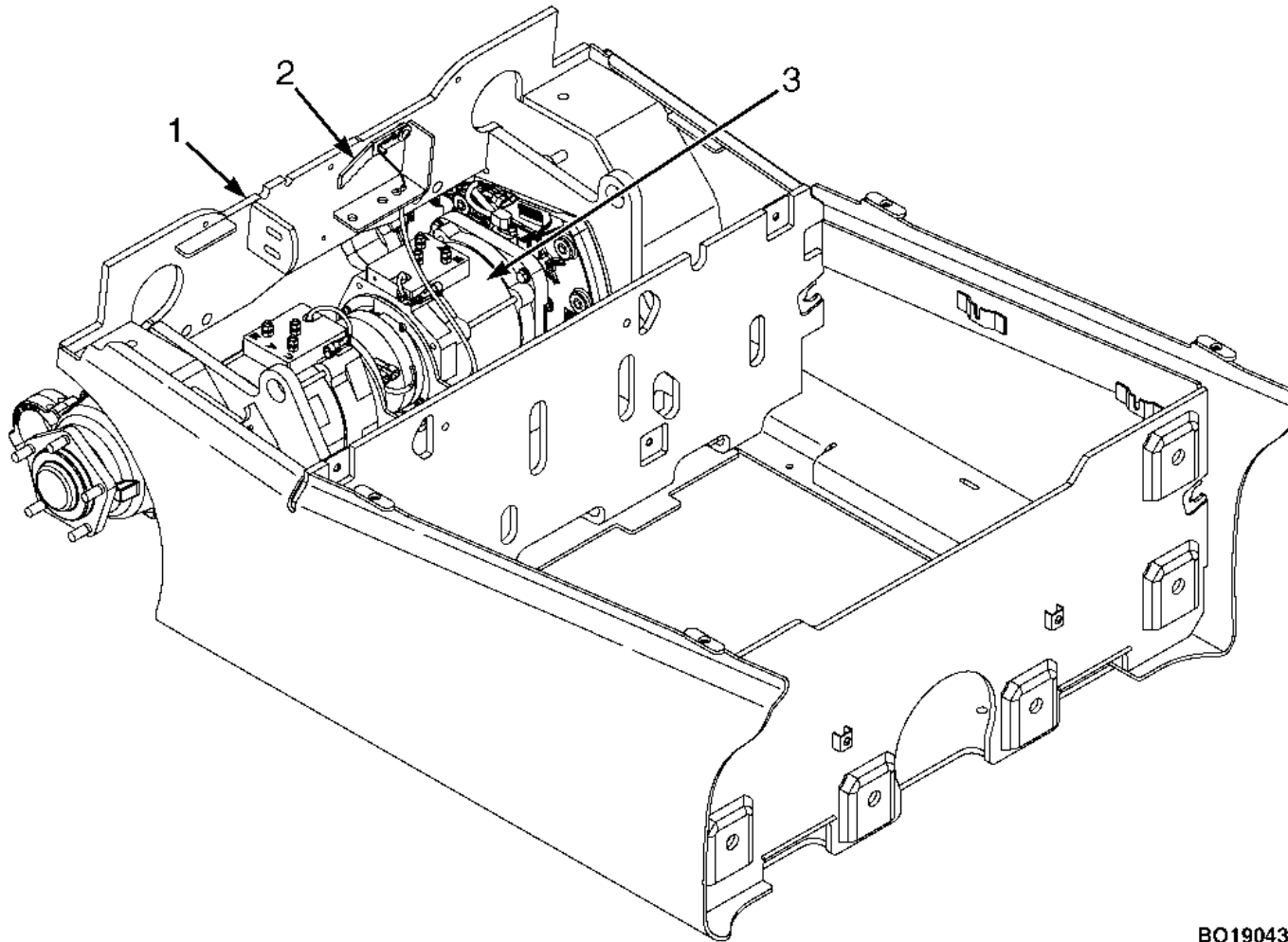

1. FRONT BULKHEAD
2. MANUAL OVERRIDE HANDLE
3. TRACTION MOTOR

BO190435

Figure 20. Automatic Parking Brake Override Handle



Operating Procedures

HYSTER

Load Handling - General

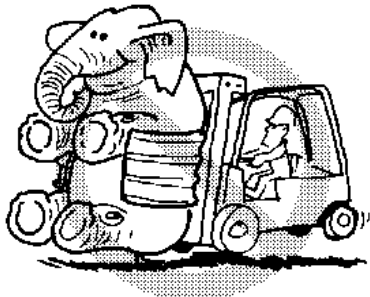

BO190124

1. Handle only loads within the capacity as shown on the Nameplate. This rating represents the maximum load that can be lifted. However, such factors as weak floors, uneven terrain, special load handling attachments, or loads having a high center of gravity can

mean that the safe working load is less than the capacity. When such conditions exist, the operator must reduce the load so that the lift truck will remain stable.

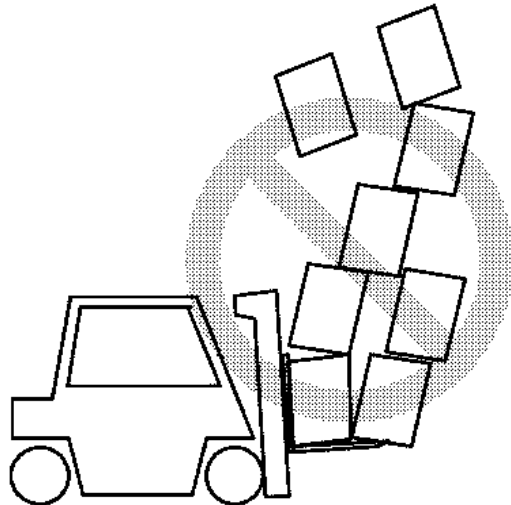

BO190126

2. Handle only stable loads. A load can have unstable items that can easily shift and fall on someone. Do not handle a load if any loose part of it is above the load backrest or any part of the load is likely to fall.

3. Position each fork the same distance from the center of the carriage. This action will help center the load on the carriage. Set the forks as far apart as possible for maximum support of the load. Center the weight of the load between the forks.

4. Check the condition of the driving surface. Verify the floor will support the weight of the lift truck and the load.

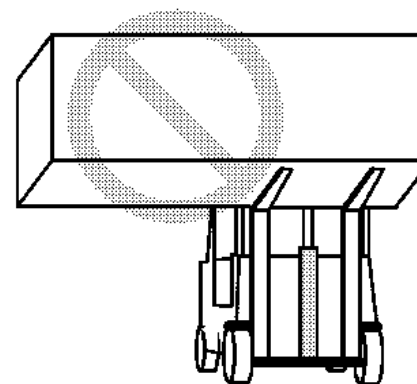

BO190127

If the weight of the load is not centered between the forks, the load can fall from the forks when you turn a corner or hit a bump. An off center load will increase the possibility of the truck tipping over to the side. Verify the pins that keep the forks in position are engaged so that the forks cannot move.

HYSTER

Operating Procedures

Lifting, Lowering, and Tilting

NOTE: The lift trucks covered in this manual can be equipped with either standard manual hydraulic levers or Electro-Hydraulic (E-Hydraulic) mini-levers. See **Figure 8**, **Figure 9**, and **Table 1**.

When possible, keep both hands on the steering wheel. During most loading or unloading operations, the operator steers with the left hand. The right hand is used to operate the lift, tilt, and attachment controls.

The **LIFT** and **TILT** functions are controlled by separate manual levers or optional mini-levers. See the **Operator Controls** section in the **Model Description** section for the correct operation.

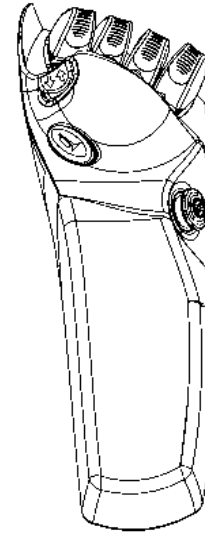

B0190400

The speed of the hydraulic functions is controlled by the position of the control levers. The farther the manual hand lever or mini-lever is moved from the **NEUTRAL** position, the faster the speed of the hydraulic function.

Do not lift or hit anything that can fall on the operator or a bystander. Remember, a lift truck equipped with a **Hyster** overhead guard and load backrest extension provides reasonable protection to the operator from falling objects, but cannot protect against every possible impact.

Operating Procedures

HYSTER

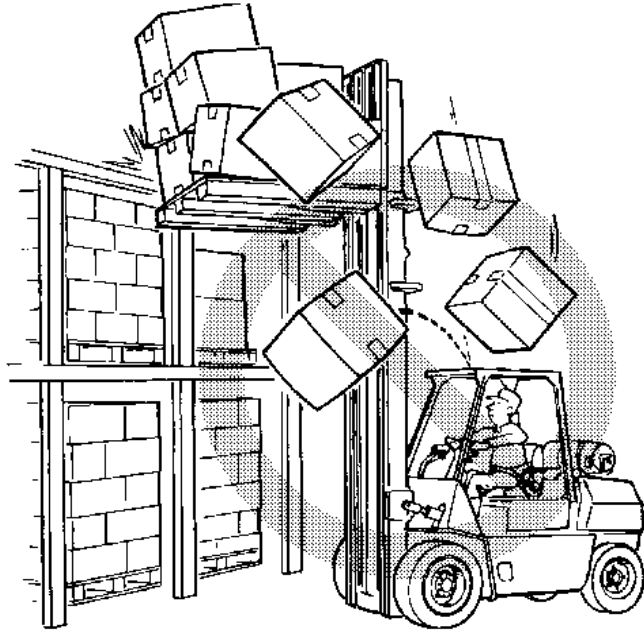

BO190128

A lift truck without an overhead guard provides no such protection and other personnel have no overhead protection. Avoid hitting objects such as stacked material that could become dislodged and fall.

The operator must exercise care while working near such objects. Whether the lift truck is loaded or empty, do not travel with the load or carriage in a raised position.

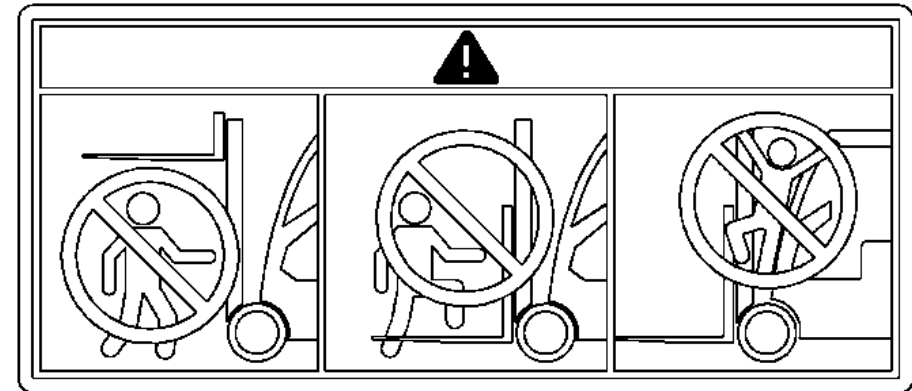

BO190290

WARNING

Keep yourself and all others clear of the lift mechanism. Never allow anyone under or on the forks.

WARNING

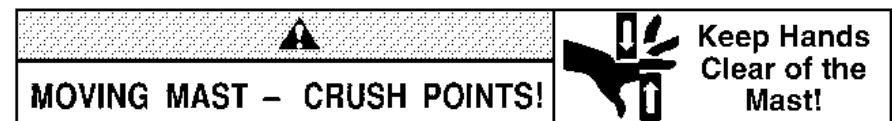

NEVER put hands, arms, head or legs through the mast or near the carriage or lift chains. This warning applies not only to the operator but also a helper. A helper must not be near the load or lift mechanism while the operator is attempting to handle a load. The



HYSTER

Operating Procedures

lift mechanism has moving parts with close clearances that can cause serious injury.

Lift and lower with the mast vertical or tilted slightly backward from vertical. Tilt elevated loads forward only when directly over the unloading place.

If the lift mechanism is raised to pick up or deposit a load, keep the tilt angle in either direction to a minimum. **Backward** and **Forward** tilt are helpful, but they affect side and forward stability.

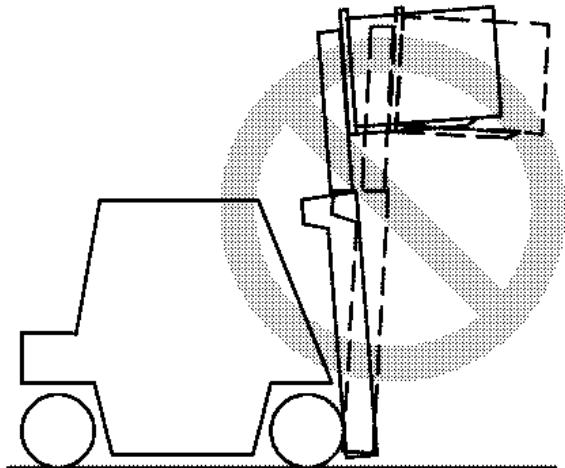

Do not tilt in either direction more than necessary when handling a load that is raised. The lift truck can tip forward

if the mast is tilted forward with a load in the raised position.

WARNING

The lift truck can tip over forward when the load is raised. Forward tipping is even more likely when tilting forward, braking when travelling forward or accelerating in reverse.

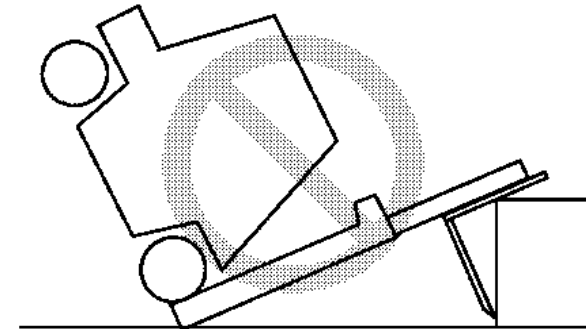

WARNING

IF THE LIFT TRUCK TIPS OVER, DO NOT JUMP OFF! HOLD FIRMLY TO STEERING WHEEL, BRACE YOUR FEET, AND LEAN AWAY FROM POINT OF IMPACT.

Operating Procedures

HYSTER

How to Engage and Disengage a Load

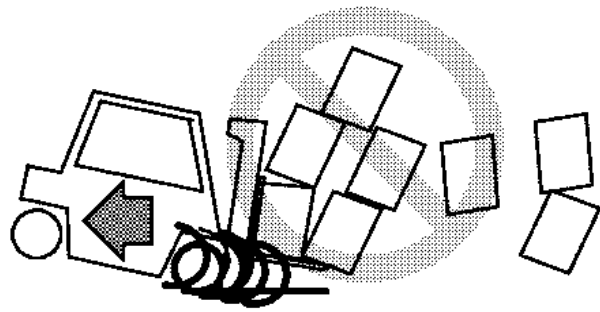

1. Avoid fast starts. Sudden movement can cause the lift truck to tip. People can be hurt or killed and material can be damaged.

Approach the load carefully. Verify that the truck is perpendicular to the load. Raise the forks to the proper height for engaging the load.

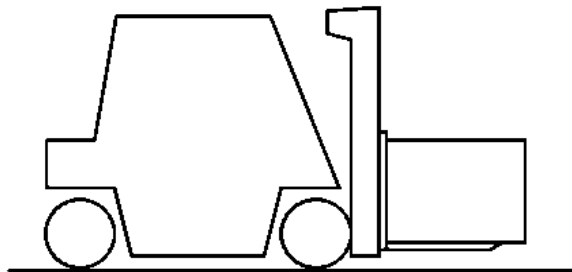

2. Move forward slowly until the forks are in position under the load. The forks must support at least two-thirds of the length of the load. Verify that the load is centered between the forks.

3. Make sure that the load is centered between the forks. Verify that the forks do not extend past the load so that loads or equipment that are behind the load being lifted are not damaged. Lift the load a small distance from the floor to verify the lift truck has the capacity to lift the load.

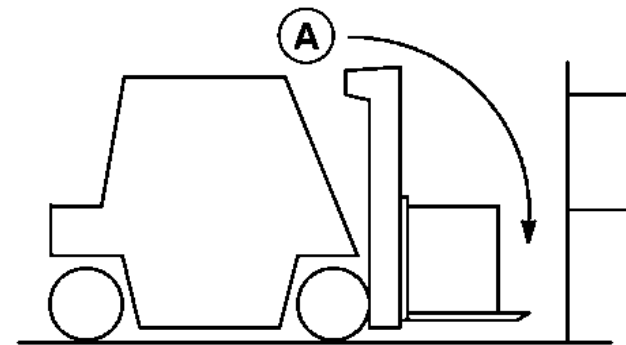

A. BE CAREFUL OF FORKS BEYOND THE LOAD.

4. If the forks are longer than the load, move the forks under the load so that the tips of the forks do not extend beyond the load. Lift the load from the surface. Move **Backward** a few inches, then lower the load onto the surface and inch **Forward** to engage the load against the carriage. Tilt the mast backward just far enough to lift the load from the surface.

HYSTER

Operating Procedures

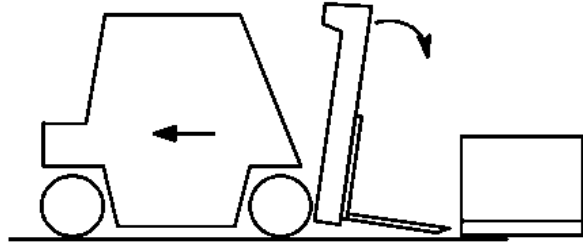

5. When a load is put on the floor, tilt the mast forward to a vertical position and lower the load. Tilt the mast forward to permit smooth removal of the forks. Carefully move the lift truck backward to remove the forks from under the load.

6. If the load is being removed from a stack, slowly move the lift truck away from the stack. When the load is clear of the stack, lower the load for traveling.

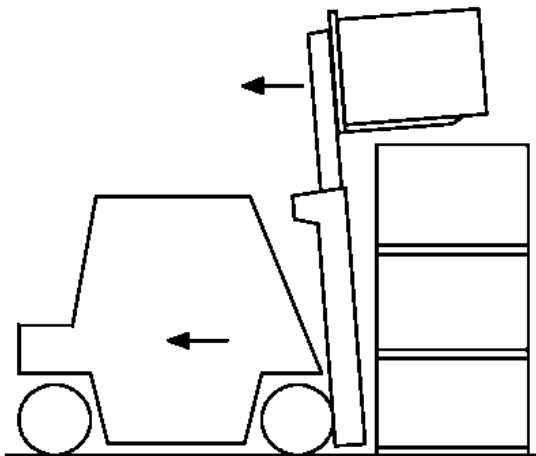

Always travel with the load as low as possible and tilted backward. Lowering speed is controlled by the position of the control lever. Lower slowly and smoothly. Slowly return the control lever to the **Neutral** position so that the load is not dropped or that the lift truck is not tipped over due to the rapid stop of the load.

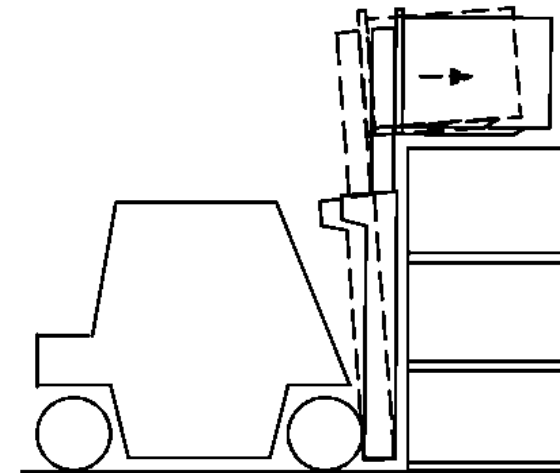

7. To put the load on a stack, align the lift truck with the stack. Lift the load to eye level and then tilt the load forward until it is level. Raise the load higher than the point where it will be placed. Do not raise the load to a point below where the load is to be placed and jog the load up into position. This operation uses added energy, particularly with an

Operating Procedures

HYSTER

electric lift truck. Use caution not to damage or move adjacent loads.

WARNING

Move carefully and smoothly when the load is raised over a stack. When the load is elevated the center of gravity of the lift truck and the load is much higher. The lift truck can tip over when the load is raised.

WARNING

If the lift truck tips over either to the side or forward, do not jump off! Hold firmly to steering wheel, brace your feet, and lean forward and away from the point of impact.

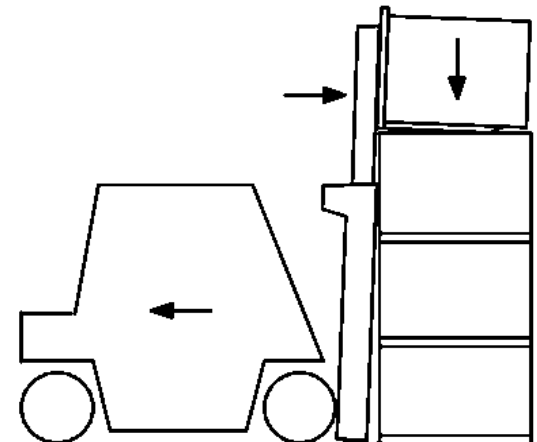

8. Move **Forward** slowly. When the load is in position, lower the load on to the stack or the rack. Lower the forks just enough to remove them from under the load. Do not lower the forks so that they will drag on the surface under the load. Carefully move the lift truck **Backward** to remove the forks from under the load. Lower the forks when traveling.

NOTE: Not every load can be lifted using only the forks of a lift truck. Some loads will require a special attachment.

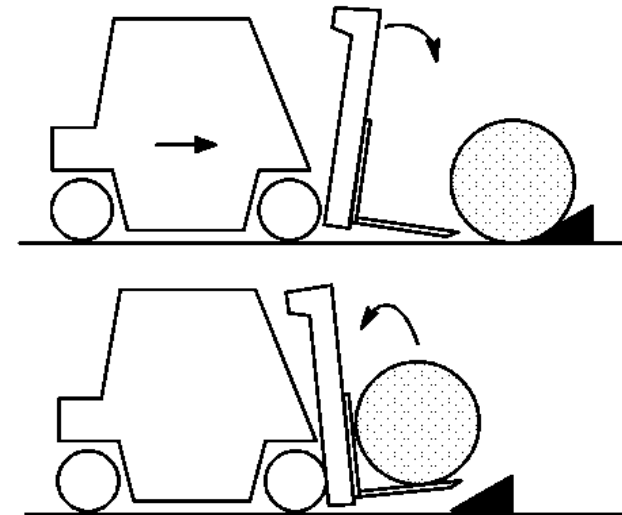

9. When lifting round objects, use a block behind the object. Tilt the mast forward so that the forks can slide



HYSTER

Operating Procedures

along the floor under the object to be lifted. Tilt the mast fully backward to help keep the load on the forks.

Load Handling, Traveling

1. When traveling with the load lowered, keep the load against the carriage and the mast tilted fully backward. This action will help keep the load on the forks and provide good forward and side stability.

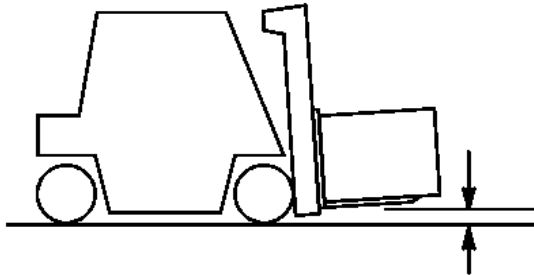

2. Travel with the lift mechanism raised only enough to clear the ground or obstacles. When any part of the mast is raised, with or without a load, the stability of the lift truck is reduced. The ability of the lift truck to resist side tipping can be less for a lift truck that is not carrying a load than it is for a lift truck that is carrying a load in the lowered (travel) position.

Therefore, a lift truck without a load is more likely to tip sideways, especially in a turn, than a lift truck with a load, provided the load is carried in the lowered position.

WARNING

Some lift trucks have mirrors for viewing along the side to observe the tail swing area. These mirrors are an aid to the driver, but are NOT driving mirrors and must NOT be used as such when operating in reverse. Always look in the direction of travel to avoid damage to something or injury to someone.

3. For better visibility with large loads, travel with the load trailing, but always keep a proper lookout in the direction of travel. Normally, direction of travel is determined by the best visibility available to the operator.

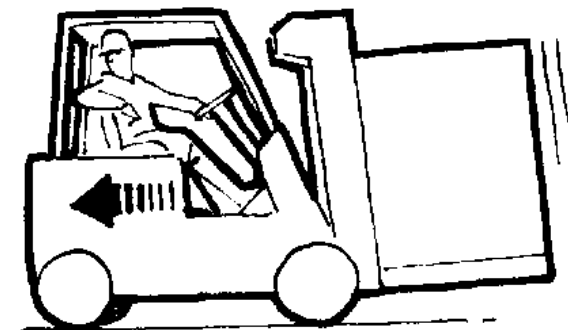



Operating Procedures

If the lift truck must travel in a direction where visibility is obstructed, a lookout helper may be required.



BO190143

4. When traveling up or down a grade with a heavily loaded lift truck, keep the load upgrade to maintain control. When operating an unloaded lift truck on a steep grade, keep the battery and counterweight upgrade.

5. Watch out for pedestrians at all times. Do not drive up close to anyone standing in front of an object. Use extra care at cross aisles, doorways, and other locations where pedestrians can step into the path of travel of the lift truck.



BO190144

Slow down when approaching blind intersections or turns. Sound the horn to warn pedestrians that there is a vehicle in the area and to be alert to possible danger.

6. Anytime the lift truck is moving, keep arms, legs, etc., inside the operator's compartment. Arms and legs outside the machine can be injured when passing obstructions.

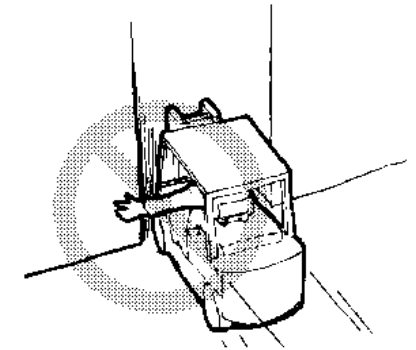

BO190145

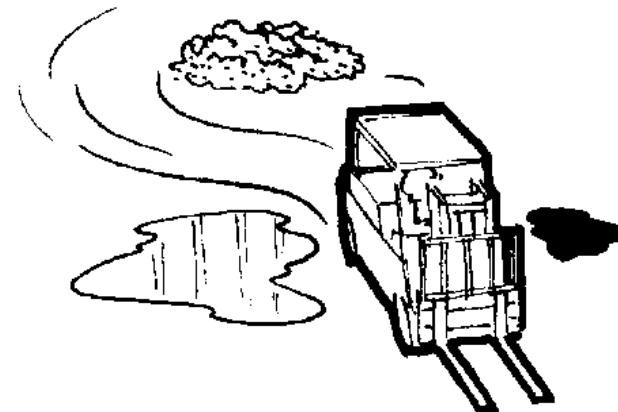

BO190146

7. Avoid bumps, holes, slick spots, and loose materials that may cause the lift truck to swerve or tip. If unavoidable, slow down.

WARNING

Serious accidents can be caused by mast and overhead guards hitting pipes and beams near the ceiling.



HYSTER

Operating Procedures

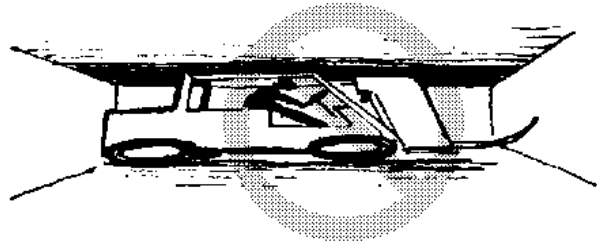

BO190147

8. Watch clearances, especially forks, mast, overhead guard, and tailswing. A lift truck is designed to perform a wide variety of functions within limited space.

The operator must be aware that the forks can sometimes extend beyond the front of the load. If the forks extend beyond the load, the operator can hit an object or lift another load.

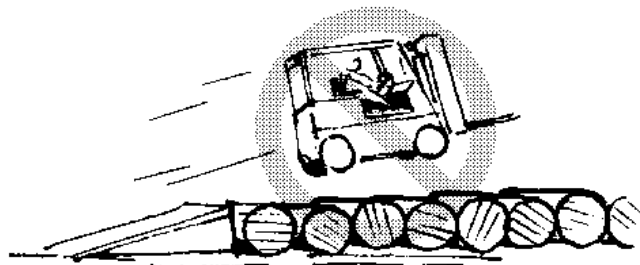

BO190148

9. Do not indulge in stunt driving or horseplay.

10. Do not pass another lift truck traveling in the same direction at intersections, blind spots, or at other dangerous locations.

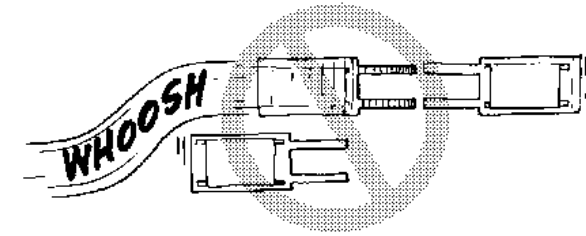

BO190149

11. Stay away from the edge of the road. Keep the wheels of the lift truck, particularly the steer wheels, on the roadway. If the wheels are allowed to run off the edge of the travel surface onto soft ground, the lift truck can tip over.

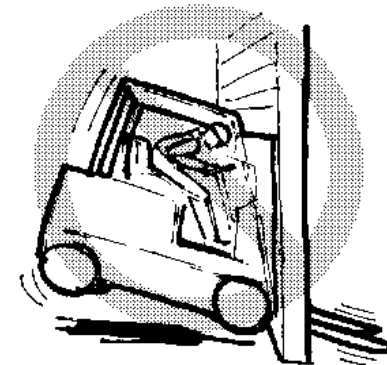

BO190150



Operating Procedures

HYSTER

12. Under all travel conditions, operate the lift truck at a speed that will permit it to be brought to a stop in a safe manner.

Load Handling, Emergency Load Lowering

WARNING

When the electronic signal is disrupted, the mast assembly can **ONLY** be lowered with the emergency load lowering valve, located on the main hydraulic valve. When using the emergency load lowering valve to lower a load, serious injury can result if anyone is near or under the load. See **Figure 21** and **Figure 22**.

WARNING

When the electronic signal is disrupted and the mast assembly is in a raised position, always lower the mast assembly with the load lowering valve before leaving the lift truck unattended.

NOTE: The emergency load lowering valve is to be used **ONLY** if the electrical signal to the main control valve has been disrupted and there is a load lifted.

The emergency load lowering valve is located on the front side of the main control valve. See **Figure 21** and **Figure 22**.

Manual Main Control Valve

To use the emergency load lowering valve, follow these steps:

1. Remove floor mat and floor plate.
2. Turn the emergency load lowering valve counterclockwise. The more opened the valve is, the faster the load is lowered. See **Figure 21**.
3. When load has been safely lowered, turn the valve clockwise until it is tight to set the emergency load lowering valve back into operation mode.
4. Install floor plate and floor mat.

HYSTER

Operating Procedures

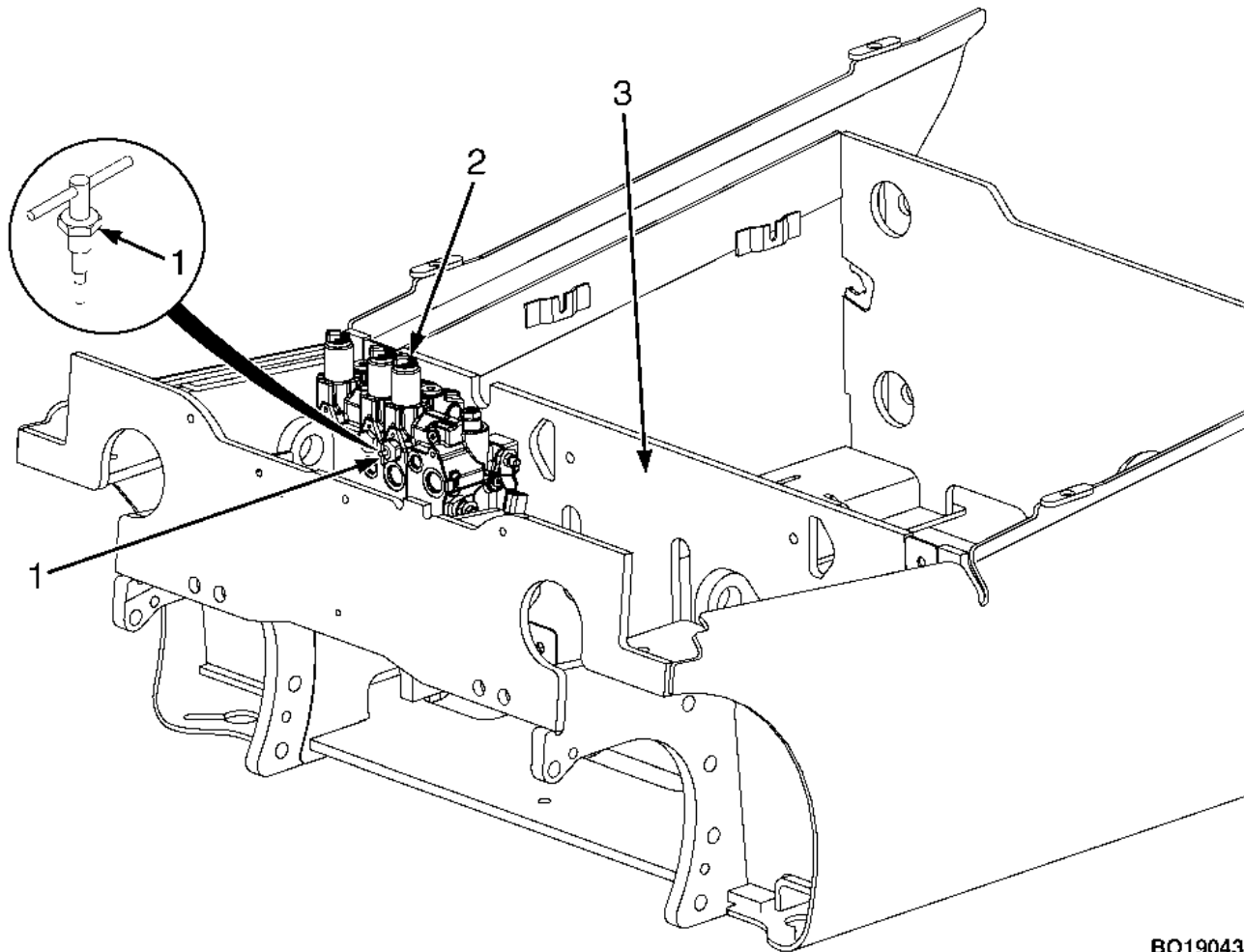

1. EMERGENCY LOAD LOWERING VALVE
2. MAIN CONTROL VALVE
3. FRONT BULKHEAD

BO190432

Figure 21. Emergency Load Lowering Valve, Manual Main Control Valve



Operating Procedures

HYSTER

E-Hydraulic Main Control Valve

To use the emergency load lowering valve, follow these steps:

1. Remove floor mat and floor plate.
2. Press the emergency load lowering valve in and rotate it 1/4 turn in any direction, then release by removing finger from valve. See **Figure 22**.

3. To disengage the emergency load lowering valve, press back in and rotate 1/4 turn in any direction. When disengaged, the red plunger will extend slightly further out of the body of the valve.

4. Install floor plate and floor mat.

HYSTER

Operating Procedures

1. EMERGENCY LOAD LOWERING VALVE
2. MAIN CONTROL VALVE
3. FRONT BULKHEAD

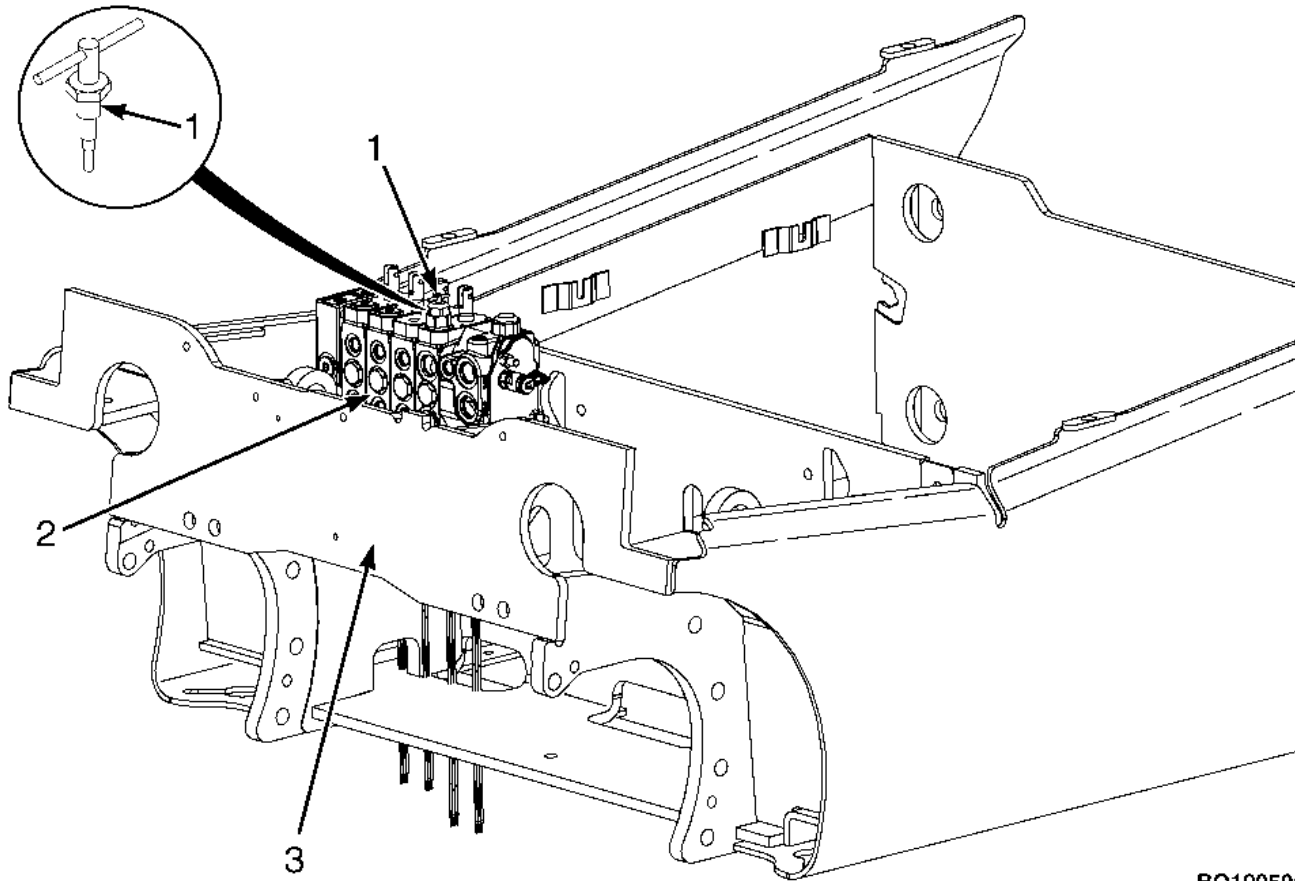

BO190505

Figure 22. Emergency Load Lowering Valve, E-Hydraulic Main Control Valve

Operating Procedures

HYSTER

Highway Truck, Railroad Cars, and Docks

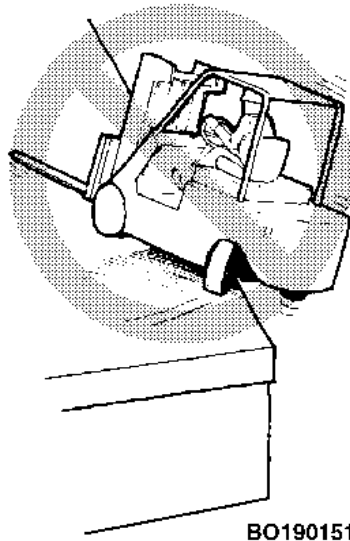

⚠️ WARNING

Maintain a safe distance from the edge of docks, ramps, platforms, and other similar working surfaces. Watch the "tail swing." Remember when travelling in the forward direction and the steering wheel is turned to move the lift truck away from the edge of the dock the rear will swing toward the edge. This action can cause the lift truck to fall off the dock.

IF THE LIFT TRUCK FALLS OFF THE DOCK, DO NOT JUMP OFF! HOLD FIRMLY TO STEERING WHEEL, BRACE YOUR FEET, AND LEAN FORWARD AND AWAY FROM THE POINT OF IMPACT.

Before operating in a highway truck or railroad car, observe the following:

DO NOT use a lift truck to move a railroad car.

DO NOT use a lift truck to open or close the door on a railroad car unless the lift truck has an attachment that is specifically designed for opening and closing railroad car doors and the operator is trained in its use.

Check to make sure that the brakes on the highway truck are set and that wheel blocks have been placed on both sides of the rear wheels (unless a dock locking mechanism is engaged). Fixed jacks may be necessary to support the front and rear of a highway truck trailer to prevent it from moving or tipping during loading or unloading.

HYSTER

Operating Procedures

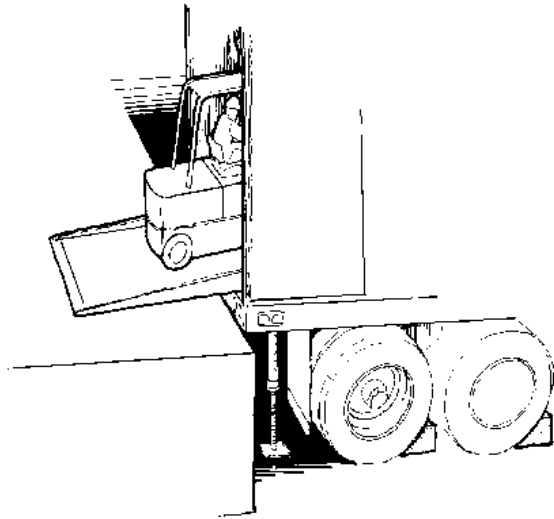

BO190152

Make sure that the railroad car brakes are set and the wheels are blocked while loading or unloading. Do this so that the railroad car will not move due to the movement of the lift truck in and out of the railroad car.

Check the condition of the driving surface. Make sure the floor will support the weight of the lift truck and the load before operating on that surface.

Make sure the dock board is secured, in good condition and of the proper capacity.

When entering a railroad car the operator can enter at an angle (if the dock plate or bridge is wide enough). This will reduce the turning required after entering.

Attachments

WARNING

Make sure the Nameplate is correct if an attachment has been installed.



BO190153

If an attachment is installed on the lift truck, make sure the operating instructions are available and understood before operating the attachment. See **Table 4** for the operation of attachment control levers. Attachments must be removed or installed by trained personnel only.

Operating Procedures

HYSTER

Stopping

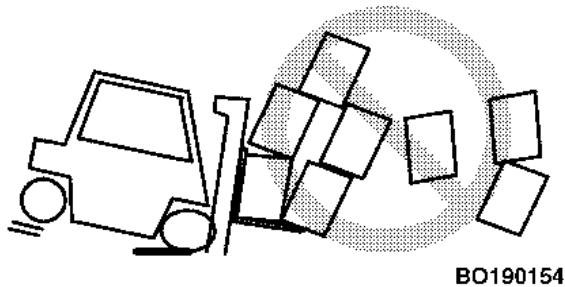

Stop the lift truck as gradually as possible. Hard braking and wheel sliding can cause the load to fall off of the forks and damage the load or hurt someone. The lift truck can also be stopped using regenerative braking (see **Model Description**) or plugging. Regenerative braking and plugging minimize brake wear damage.

Parking

WARNING

ALWAYS apply the parking brake when you leave the lift truck. **Never** apply parking brake while truck is moving.

The operator must never leave a lift truck in a condition so that it can cause damage and injury. When parking the lift truck, do the following operations:

1. Stop the lift truck. The parking brake is automatically applied.
2. Fully lower the forks or carriage. Tilt mast forward until the tips of the forks touch the ground.
3. Turn the key or keyless switch to the **OFF** position. See **Figure 11**.
4. To release seat belt, press red release button, and guide belt carefully back into the retractor with your hand.
5. Disconnect the battery when leaving the lift truck between shifts or for an extended period.
6. If the lift truck must be left on an incline, put blocks on the down hill side of the wheels so that the lift truck cannot move.
7. Do not park the lift truck so that it limits access to fire aisles, stairways, and fire equipment.



HYSTER

Maintenance

Maintenance

General

WARNING

DO NOT make repairs or adjustments unless you have both authorization and training. Repairs and adjustments that are not correct can make a dangerous operating condition.

DO NOT operate a lift truck that needs repairs. Report the need for repairs immediately. If repair is necessary, put a **DO NOT OPERATE** tag in the operator's area. Remove the key from the key switch. Disconnect the battery connector.

DO NOT work under a raised carriage. Lower the carriage or use a chain to prevent the carriage and the inner or intermediate weldments from lowering when doing maintenance. Make sure that the moving parts are attached to parts that cannot move.

CAUTION

Disposal of lubricants and fluids must meet local environmental regulations.

This section contains a **Maintenance Schedule** and instructions for daily maintenance and inspection. The **Maintenance Schedule** has time intervals for inspection, lubrication, and maintenance for your lift truck. The service intervals are provided in both operating hours recorded on the lift truck hourmeter, and in calendar time. Use the interval that occurs first.

The recommendation for time intervals are for one SHIFT of operation per day. Time intervals must be decreased from the recommendations in the **Maintenance Schedule** for the following conditions:

- If the lift truck is used more than one shift per day.
- If the lift truck must work in dirty operating conditions.
- Poor ground conditions.
- Intensive usage at high performance levels or other abnormal conditions will require more frequent servicing.

The **Maintenance Schedule** has four time periods. Perform maintenance at the SHIFT, 6-MONTHS, 1-YEAR, and 2-YEAR periods.



Maintenance

HYSTER

Your dealer for **Hyster** lift trucks will advise you on the maintenance time intervals based on their survey of the application.

Your dealer for **Hyster** lift trucks has the equipment and trained service personnel to do a complete program of inspection, lubrication, and maintenance. A regular program of inspection, lubrication, and maintenance will help your lift truck provide more efficient performance and operate for a longer period of time.

Some users have service personnel and facilities to do the items listed in the **Maintenance Schedule**. Service manuals are available from your dealer for **Hyster** lift trucks to help users who do their own maintenance.

Throughout this manual, forward will refer to travel in the direction of the forks and left and right will be determined by sitting in the seat facing forward. See **Figure 23**.

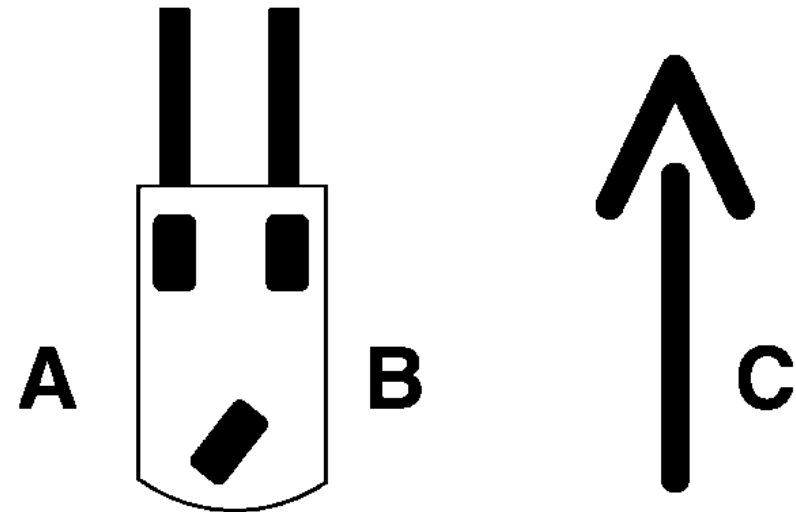

BO190444

- A. LEFT SIDE
- B. RIGHT SIDE
- C. FORWARD TRAVEL

Figure 23. Truck Orientation

Serial Number Data

The serial number code for the lift truck is on the Nameplate. The code is also stamped on the left side of the front face of cowl. See **Figure 24**.

HYSTER

Maintenance

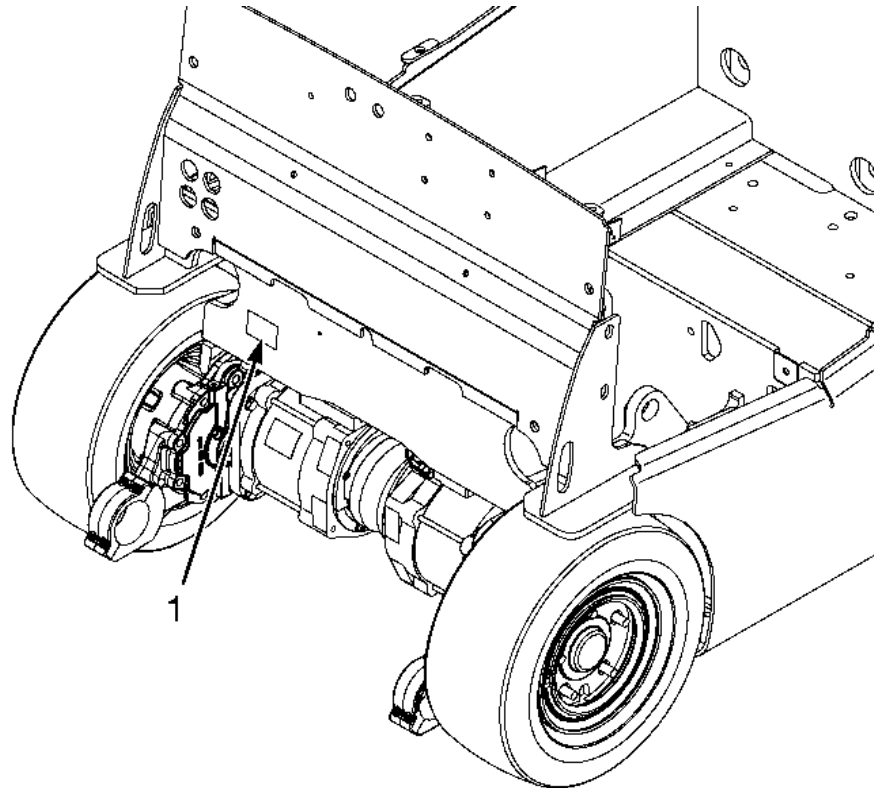

BO120004

1. SERIAL NUMBER

Figure 24. Serial Number Stamp

How to Move a Disabled Lift Truck

⚠ WARNING

Use extra care when towing a lift truck if there is a problem with any of the following:

- Brakes do not operate correctly.
- Steering does not operate correctly.
- Tires are damaged.
- Traction conditions are bad.
- The lift truck must be moved on a steep grade.

If the hydraulic pump motor, which includes the steering control functions, does not operate, steering control of the lift truck can be slow. This can make the control of the lift truck difficult. If there is no electrical power, there is no power steering. **DO NOT** tow the lift truck if there is no power. Poor traction can cause the disabled lift truck or towing vehicle to slide. Steep grades will require additional brake force to stop the lift truck.



Maintenance

HYSTER

WARNING

Never carry a disabled lift truck unless the lift truck **MUST be moved and cannot be towed. The lift truck used to carry the disabled lift truck **MUST** have a rated capacity equal to or greater than the weight of the disabled lift truck. The capacity must be for a load center equal to half the width of the disabled lift truck.**

See the Nameplate of the disabled lift truck for the approximate total weight. The forks must extend the full width of the disabled lift truck. Center the weight of the disabled lift truck on the forks and be careful not to damage the under side of the lift truck.

How to Tow the Lift Truck

1. The towed lift truck must have an operator.
2. Raise the carriage and forks approximately 300 mm (12 in.) from the surface. Install a chain to prevent the carriage and mast channels from moving.

3. Tow with another lift truck of *equal* or *greater* capacity than the disabled lift truck. Install a load of approximately half-capacity on the forks of the lift truck that is being used to tow the disabled lift truck. The half-capacity load will increase the traction of the lift truck. Keep the load as low as possible.
4. Use a towing link made of steel that fastens to the tow pins in the counterweights of both lift trucks.
5. Pull up on the manual override handle to release the automatic parking brake. See **Figure 25**.
6. Tow the lift truck slowly.

HYSTER

Maintenance

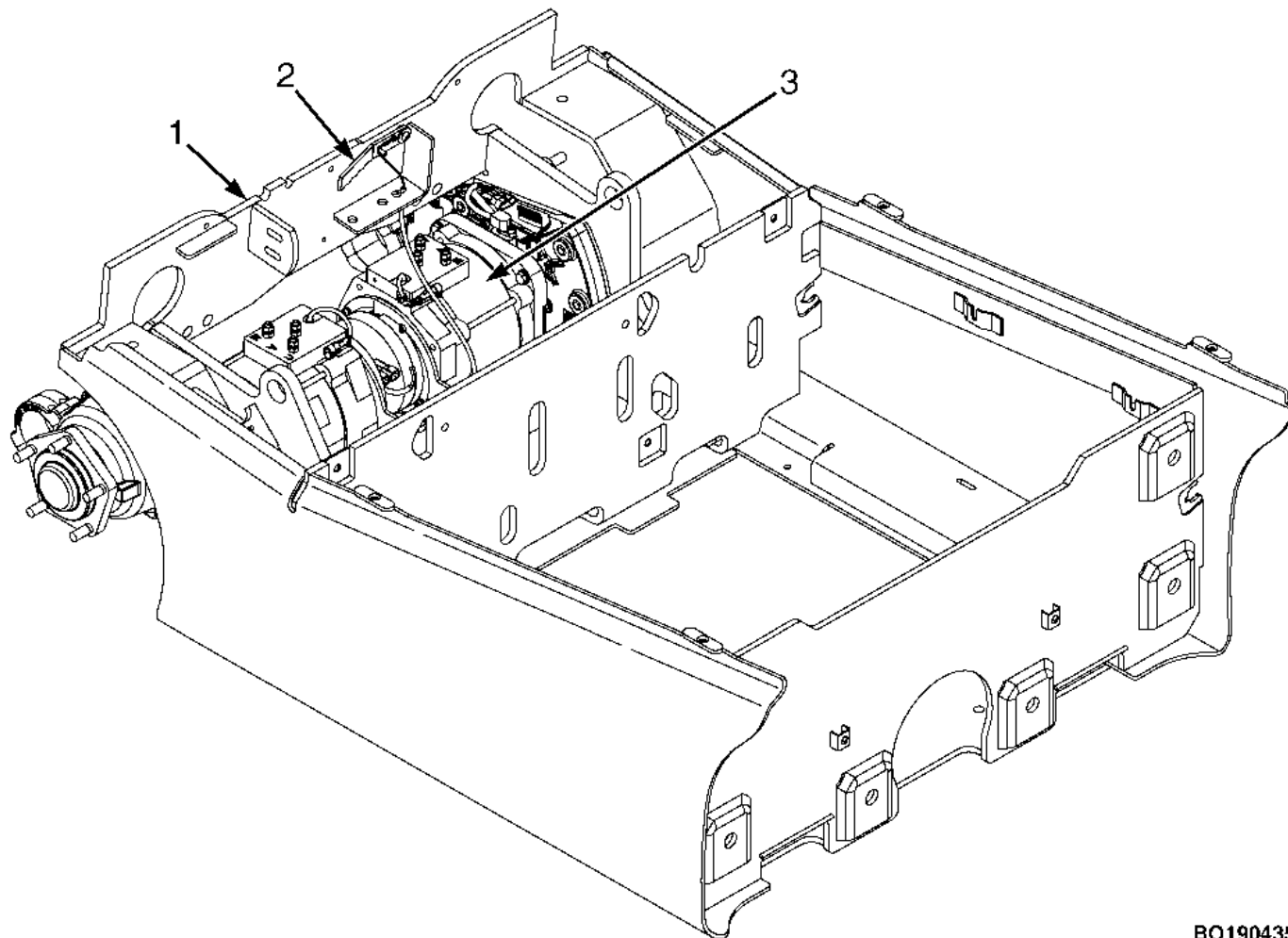

1. FRONT BULKHEAD
2. MANUAL OVERRIDE HANDLE
3. TRACTION MOTOR

BO190435

Figure 25. Automatic Parking Brake Override Handle



Maintenance

HYSTER

How to Put a Lift Truck on Blocks

WARNING

The lift truck must be put on blocks for some types of maintenance and repair. The removal of the following assemblies will cause large changes in the center of gravity: mast and drive axle assembly, battery, and the counterweight. When the lift truck is put on blocks, put additional blocks in the following positions to maintain stability:

- Before removing the mast and drive axle assembly, put blocks under the counterweight so that the lift truck cannot tip backward.
- Before removing the battery and counterweight, put blocks under the mast assembly so that the lift truck cannot tip forward.

Put the lift truck on blocks only if the surface is solid, even, and level. Make sure that any blocks used to support the lift truck are solid, one-piece units.

How to Raise the Drive Tires

1. Put blocks on each side (front and back) of the steer tires to prevent movement of the lift truck. See **Figure 26**.

2. Put the mast in a vertical position. Put a block under each outer mast channel.

3. Tilt the mast fully forward until the drive tires are raised from the surface.

4. Put additional blocks under the frame behind the drive tires.

5. If the hydraulic system will not operate, use a hydraulic jack under the side of the frame near the front. Make sure that the jack has a capacity equal to at least half the weight of the lift truck. See the Nameplate.

How to Raise the Steer Tire

NOTE: Under the counterweight cover is a hole to insert a lifting eye. This lifting point can be used to raise the steer tire so that blocks can be positioned under the frame.

1. Put blocks on both sides, front and back, of the drive tires to prevent movement of the lift truck. See **Figure 26**.

2. Use a hydraulic jack to raise the steering tires. Verify that the jack has a capacity of at least two thirds of the total weight of the lift truck as shown on the Nameplate.

3. Put the jack under the frame to raise the lift truck. Put blocks under the frame to support the lift truck.

HYSTER

Maintenance

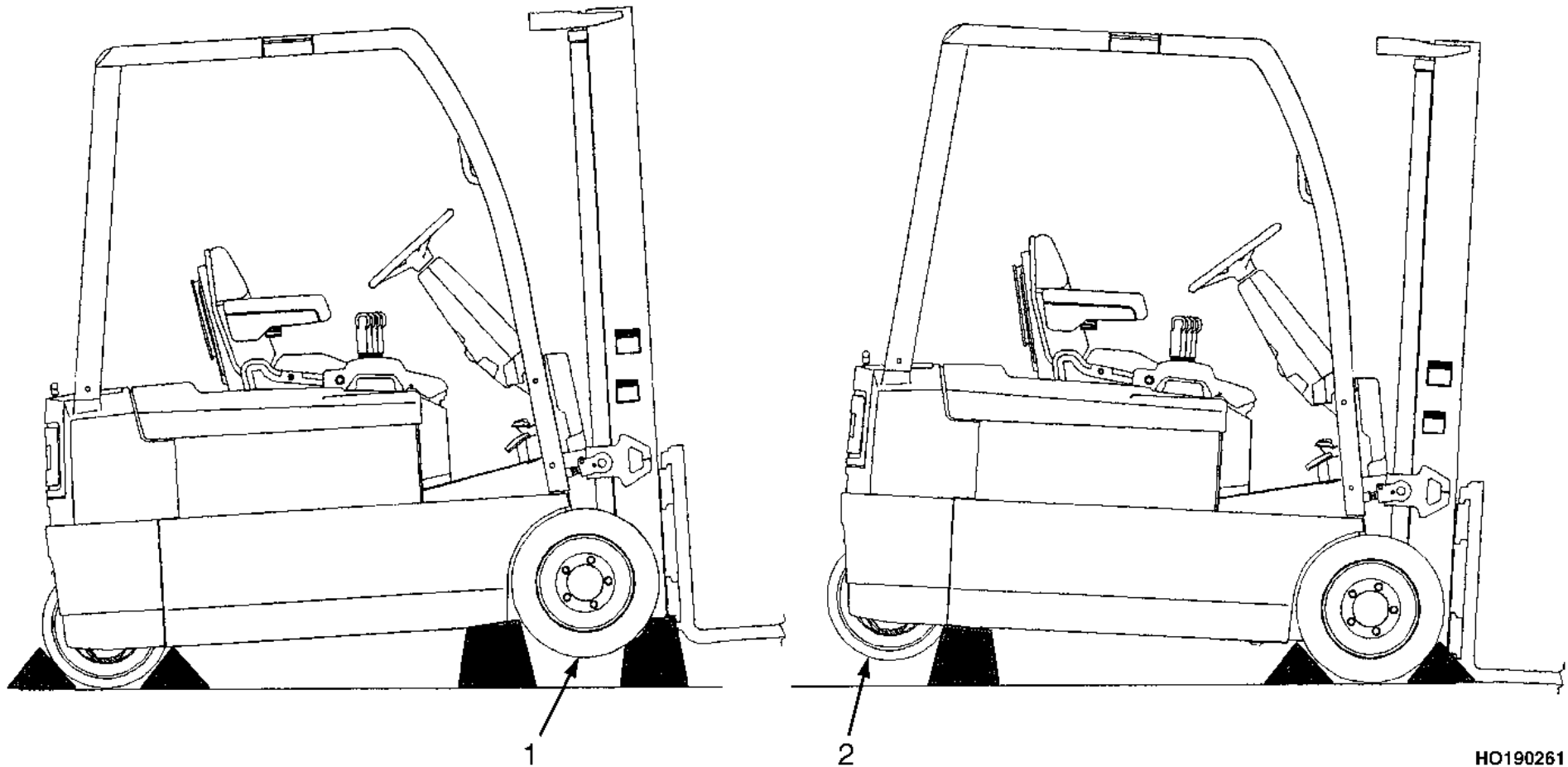

1. DRIVE TIRES

2. STEER TIRES

HO190261

Figure 26. Putting the Lift Truck on Blocks



Maintenance Schedule

HYSTER

How to Clean a Lift Truck



CAUTION

Your lift truck may be damaged if water or cleaning agents come in contact with electrical components. **DO NOT** directly spray any electrical components, especially connectors, switches, electro-hydraulic controls,

battery area, and dash display during the cleaning process.

Portions of your lift truck may be washed with a non-heated pressure washer. Steam cleaning is not recommended in most instances, as condensation may form in electrical components causing damage or erratic behavior. For cleaning guidelines and components to avoid, see the **Periodic Maintenance** section of the **Service Manual** for your lift truck.

HYSTER

Maintenance Schedule

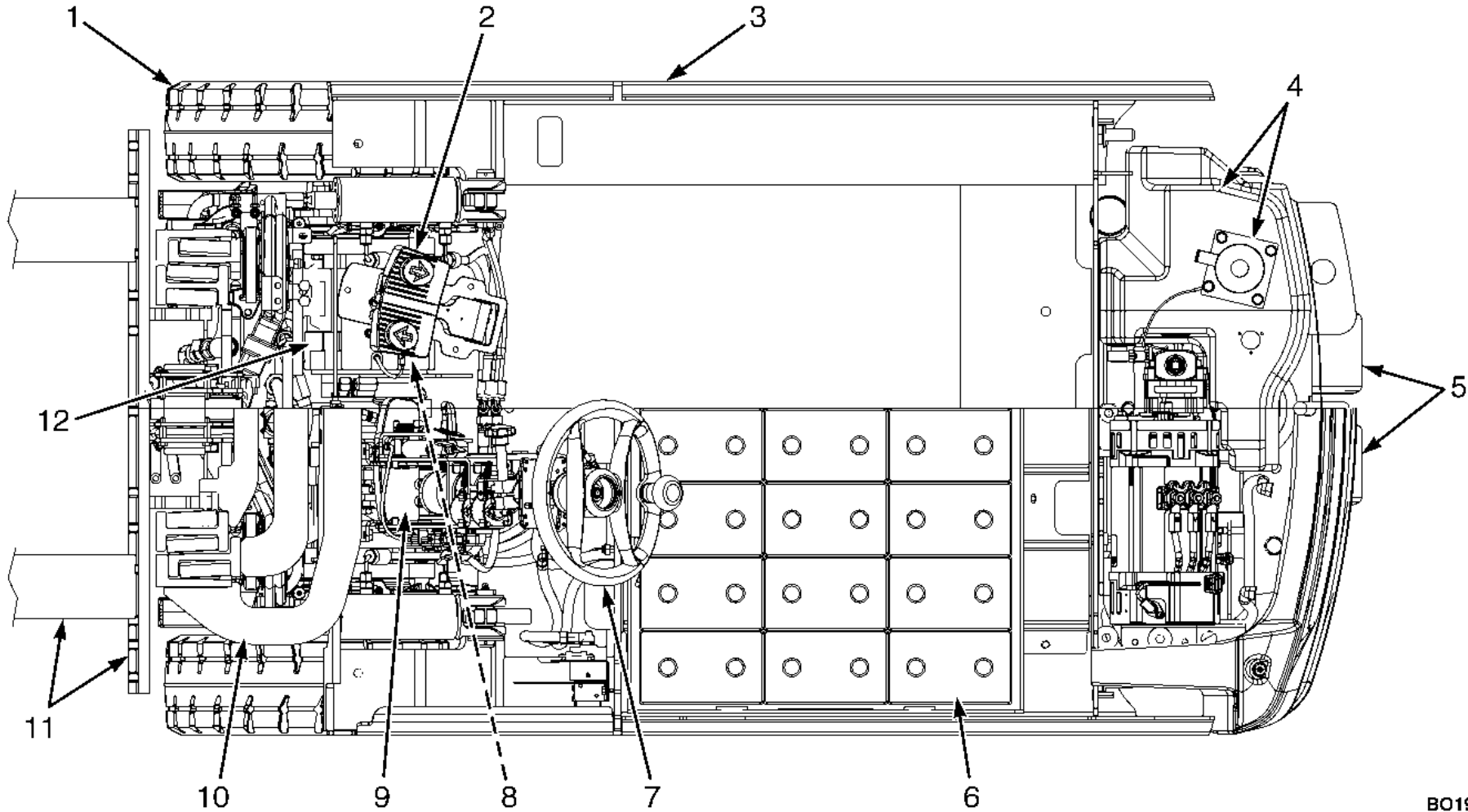

BO190425

Figure 27. Maintenance Points, Lift Trucks Manufactured Before March, 2015

Maintenance Schedule

HYSTER

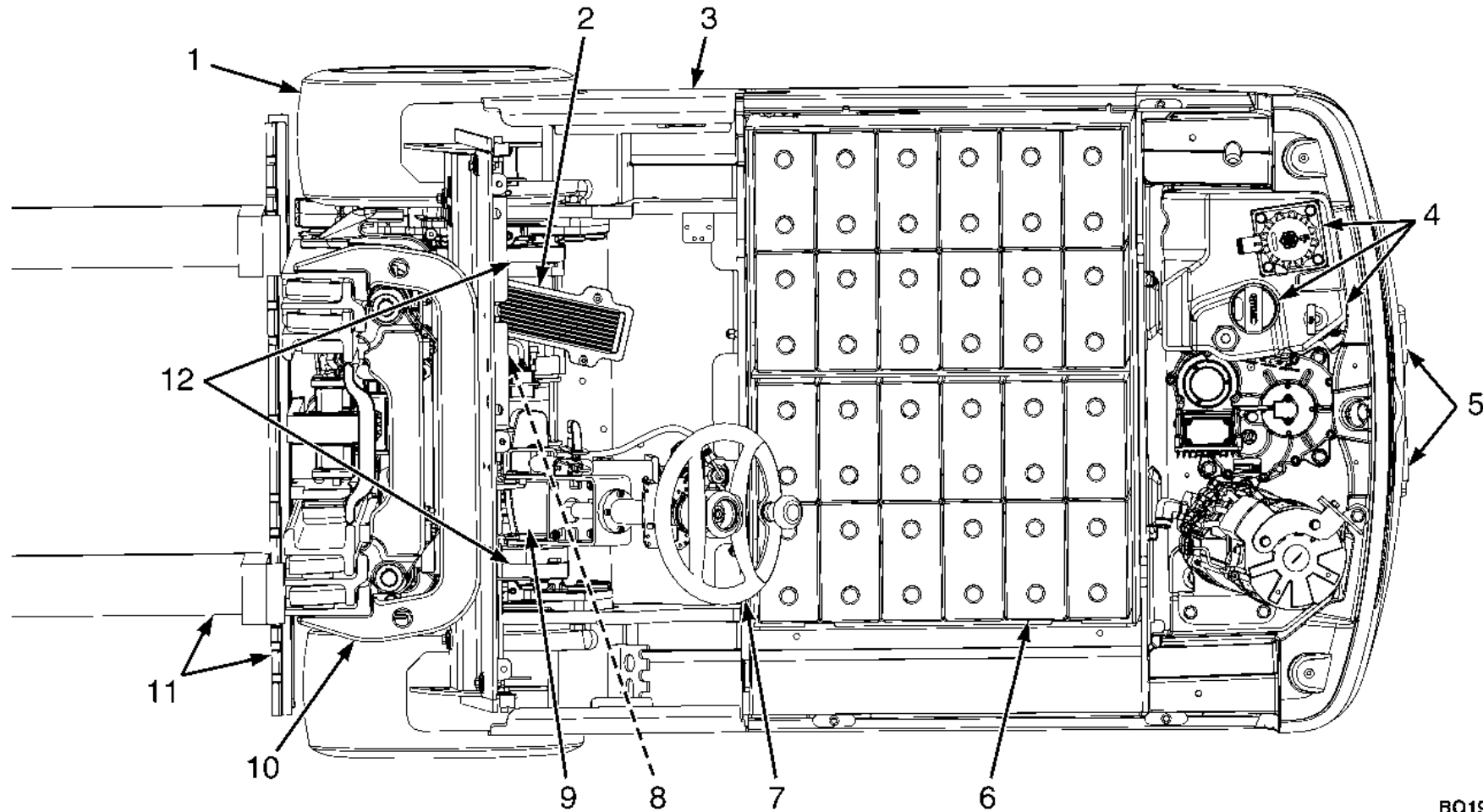

BO191151

Figure 28. Maintenance Points, Lift Trucks Manufactured After February, 2015



HYSTER

Maintenance Schedule

Maintenance Schedule

Table 9. Maintenance Schedule (See Figure 27 and Figure 28)

Item No.	Item	Shift	1000 hrs/ 6 mo	2000 hrs/ 1 yr	4000 hrs/ 2 yr	Procedure or Quantity	Specification
1	Drive Tire and Wheel Assemblies						
	Tire and Wheel	X				Check Condition. See NOTE 1.	Remove foreign objects embedded in tire.
2	Pedals, Seat Assembly, Hood, Hinges, and Hood Latch	X				Check Operation. Repair as Required.	
			L			Lube as Required.	Use Multipurpose Grease See NOTE 2. See NOTE 3.
3	Frames, Covers, and Floor Plates	X				Visually Inspect for Damage. Repair as Required.	
4	Hydraulic System	X				Check Operation. Repair as Required.	
		X				Check for Leaks. Repair as Required.	

X=Check C=Change L=Lubricate CIL=Check Indicator Light during operation.

NOTE: Never use steam to clean electrical parts.



Maintenance Schedule

HYSTER

Table 9. Maintenance Schedule (See Figure 27 and Figure 28) (Continued)

Item No.	Item	Shift	1000 hrs/ 6 mo	2000 hrs/ 1 yr	4000 hrs/ 2 yr	Procedure or Quantity	Specification
4	Hydraulic System (Cont)						
	Hydraulic Hoses, Hose Fittings, and Clamps	X				Inspect for Visible Damage and Defects. Adjust, Repair, or Replace if Necessary.	
			X			Inspect for Kinked, Flattened, Stiff or Charred Hoses. Replace if Necessary.	
	Hydraulic Oil	X				Check for Leaks. Repair as Required.	
Hydraulic Oil Standard Truck (Total Capacity)	X			C	Change Oil. 22.0 liter (5.8 gal) See NOTE 9.	0 to 48 °C (32 to 118 °F) Hydraulic Oil ISO VG 46	

X=Check C=Change L=Lubricate CIL=Check Indicator Light during operation.

NOTE: Never use steam to clean electrical parts.



HYSTER

Maintenance Schedule

Table 9. Maintenance Schedule (See Figure 27 and Figure 28) (Continued)

Item No.	Item	Shift	1000 hrs/ 6 mo	2000 hrs/ 1 yr	4000 hrs/ 2 yr	Procedure or Quantity	Specification
4	Hydraulic System (Cont)						
	Hydraulic Oil Cooler/Freezer Truck (Total Capacity)	X		C		Change Oil. 22.0 liter (5.8 gal) See NOTE 9.	-29 to 48 °C (-20 to 118 °F) Hydraulic Oil ISO VG 32 - VI ≥ 140 (High Viscosity Index Oil per ISO 11158 L-HV)
	Hydraulic Oil Sub-Zero Construction (Total Capacity)	X		C		Change Oil. 22.0 liter (5.8 gal) See NOTE 9.	-40 to 22 °C (-40 to 71.6 °F) MIL-H-5606A
	Hydraulic Oil Filter			C		Change Oil Filter. See NOTE 3 and NOTE 9.	See Parts Manual .
	Breather Cap		X	C		Clean or Replace. See NOTE 3.	See Parts Manual .
	Heater - Air Filter		C			Replace Air Filters. 2 Filters	See Parts Manual .

X=Check C=Change L=Lubricate CIL=Check Indicator Light during operation.

NOTE: Never use steam to clean electrical parts.



Maintenance Schedule

HYSTER

Table 9. Maintenance Schedule (See Figure 27 and Figure 28) (Continued)

Item No.	Item	Shift	1000 hrs/ 6 mo	2000 hrs/ 1 yr	4000 hrs/ 2 yr	Procedure or Quantity	Specification
	Heater - Heater Element		X			Clean Heater Element.	Use Compressed Air.
	Heater - Operating Condition		X			Check Operation and Heater Condition.	
5	Steering Tire and Wheel Assemblies						
	Tire and Wheel	X				Check Condition. See NOTE 1.	Remove Foreign Objects embedded in Tire.
6	Battery	X				Check Level. See NOTE 5. Check Connection Between Truck and Battery.	Use Distilled Water. Maintain in Accordance with Manufacturer's Service Instructions.
	Battery Restraint	X				Check Operation.	

X=Check C=Change L=Lubricate CIL=Check Indicator Light during operation.

NOTE: Never use steam to clean electrical parts.



HYSTER

Maintenance Schedule

Table 9. Maintenance Schedule (See Figure 27 and Figure 28) (Continued)

Item No.	Item	Shift	1000 hrs/ 6 mo	2000 hrs/ 1 yr	4000 hrs/ 2 yr	Procedure or Quantity	Specification
7	Steering System	X				Check Operation.	Repair as Required.
		X				Check for Leaks.	
	Steering Position Sensor				X	Check Sensor Assembly and Column Gear Teeth.	Replace Sensor or Column Gear as Required.
	Telescopic Steering Column				L	Lubricate.	Use Manual Steering Gear Grease. See NOTE 7.
	Steering Actuator Bolts			X		Check Torque. 3 Bolts.	270 N•m (200 lbf ft)
	Steering Plate Bolts			X		Check Torque. 4 Bolts.	305 N•m (225 lbf ft)

X=Check C=Change L=Lubricate CIL=Check Indicator Light during operation.

NOTE: Never use steam to clean electrical parts.



Maintenance Schedule

HYSTER

Table 9. Maintenance Schedule (See Figure 27 and Figure 28) (Continued)

Item No.	Item	Shift	1000 hrs/ 6 mo	2000 hrs/ 1 yr	4000 hrs/ 2 yr	Procedure or Quantity	Specification
8	Automatic Parking Brake	CIL X				Check Operation. Make Sure Applies and Releases Properly.	Must Hold Full Capacity Load on a 15% Grade.
	Manual Override Handle		L			Lubricate Pivot Pin. See NOTE 3.	Use Multipurpose Grease. See NOTE 2.
9	Service Brake (Lift Trucks Manufactured Before February, 2016, with- out E-Brake)	X				Check Operation.	Use Dexron III.
		X				Check for Leaks.	
	Linkage and Shafts		L			Lubricate.	Silicone Spray Lubricant. Hyster P/N 328388.
	Master Cylinder Reservoir	CIL	X				Check Oil Level.
				C		Change Oil. 0.25 liter (0.26 qt).	Use Dexron III.

X=Check C=Change L=Lubricate CIL=Check Indicator Light during operation.

NOTE: Never use steam to clean electrical parts.



HYSTER

Maintenance Schedule

Table 9. Maintenance Schedule (See Figure 27 and Figure 28) (Continued)

Item No.	Item	Shift	1000 hrs/ 6 mo	2000 hrs/ 1 yr	4000 hrs/ 2 yr	Procedure or Quantity	Specification
10	Mast	X				Inspect for Visible Damage. Check Operation.	
	Pivot Pins		L			2 Fittings. Check Lubrication. See NOTE 1.	Use Multipurpose Grease. See NOTE 2.
	Sliding Surfaces	X L	L			Lubricate as Required. See NOTE 1 and NOTE 4.	Use Multipurpose Grease. See NOTE 2.
	Mast Mounting Capscrews		X			Tighten if Required. See NOTE 1.	24 N•m (212 lbf in).

X=Check C=Change L=Lubricate CIL=Check Indicator Light during operation.

NOTE: Never use steam to clean electrical parts.



Maintenance Schedule

HYSTER

Table 9. Maintenance Schedule (See Figure 27 and Figure 28) (Continued)

Item No.	Item	Shift	1000 hrs/ 6 mo	2000 hrs/ 1 yr	4000 hrs/ 2 yr	Procedure or Quantity	Specification	
10	Mast (Cont)							
	Lift Chains	X				Check Stretch and Lubricate. See NOTE 3 and NOTE 6.	SAE 30W Engine Oil.	
			X			Check Adjustment and Length. See NOTE 3.		
				L		Remove Chains to Clean and Lubricate.	SAE 30W Engine Oil.	
	Header Hoses, Hose Fittings, and Clamps	X				Inspect for Visible Damage and Defects. See NOTE 1.	Adjust, Repair, or Replace if Necessary.	
		X			Inspect for Kinked, Flattened, Stiff, or Charred Hoses. Replace if Necessary.			
<p>X=Check C=Change L=Lubricate CIL=Check Indicator Light during operation. NOTE: Never use steam to clean electrical parts.</p>								



HYSTER

Maintenance Schedule

Table 9. Maintenance Schedule (See Figure 27 and Figure 28) (Continued)

Item No.	Item	Shift	1000 hrs/ 6 mo	2000 hrs/ 1 yr	4000 hrs/ 2 yr	Procedure or Quantity	Specification
	Mast Fourth Function Mini Rollers		L			Lubricate as Required. See NOTE 8.	Use Multipurpose Grease. See NOTE 2.

X=Check C=Change L=Lubricate CIL=Check Indicator Light during operation.

NOTE: Never use steam to clean electrical parts.



Maintenance Schedule

HYSTER

Table 9. Maintenance Schedule (See Figure 27 and Figure 28) (Continued)

Item No.	Item	Shift	1000 hrs/ 6 mo	2000 hrs/ 1 yr	4000 hrs/ 2 yr	Procedure or Quantity	Specification
11	Carriage Assembly	X				Inspect for Visible Damage. Check Operation.	
	Forks	X				Check Condition. Replace if Necessary.	
	Fork Guides and Pins	X	L			Lubricate as Required. See NOTE 1.	SAE 30W Engine Oil
	Integral Sideshift Carriage		L			Lubricate 2 Fittings. See NOTE 1.	Use Multipurpose Grease. See NOTE 2.
	Integral Sideshift Carriage Upper/Lower Bearings		X			Check Wear. 4 Bearings. See NOTE 1.	2.50 mm (0.098 in.) Minimum Thickness.
				C		Replace Bearings.	See Parts/Service Manual.

X=Check C=Change L=Lubricate CIL=Check Indicator Light during operation.

NOTE: Never use steam to clean electrical parts.



HYSTER

Maintenance Schedule

Table 9. Maintenance Schedule (See Figure 27 and Figure 28) (Continued)

Item No.	Item	Shift	1000 hrs/ 6 mo	2000 hrs/ 1 yr	4000 hrs/ 2 yr	Procedure or Quantity	Specification
11	Carriage Assembly (Cont)						
	Integral Sideshift Carriage Fork Positioner		L			Lubricate as Required. 2 Fittings. See NOTE 1, NOTE 3, and NOTE 8.	Multipurpose Grease. See NOTE 2.
	Integral Sideshift Carriage Lower Mounting Hook		X			Check for Wear and Clearance. See NOTE 1, NOTE 3, and NOTE 8.	0.76 mm (0.03 in.) Minimum Wear Limit.
12	Transaxle						
	Oil Change				C	Change Oil. 0.6 liter (0.63 qt)	Use GS-80W
	Breather			X		Clean and Check Operation. Replace as Necessary.	

X=Check C=Change L=Lubricate CIL=Check Indicator Light during operation.

NOTE: Never use steam to clean electrical parts.



Maintenance Schedule

HYSTER

Table 9. Maintenance Schedule (See Figure 27 and Figure 28) (Continued)

Item No.	Item	Shift	1000 hrs/ 6 mo	2000 hrs/ 1 yr	4000 hrs/ 2 yr	Procedure or Quantity	Specification
	Electric Circuits						
	Battery Disconnect Switch	X				Check Operation.	
	Horn, Lights, Alarms, and Seat Switch	X				Check Operation. Repair as Required.	
	Display Panel	X				Check Operation.	
	Contactors		X			Check Condition. Repair as Required.	
	Direction and Speed Control Pedals	X	L			Check Operation. Lubricate as Needed.	Use Silicone Spray Lubricant. Hyster P/N 328388
	Safety Labels and Operating Manual	X				Replace if Necessary.	See Parts Manual .
	Steering Column Tilt Memory Lever	X				Check Operation.	
	Seat Belt and Seat Rails	X CIL				Check Condition.	

X=Check C=Change L=Lubricate CIL=Check Indicator Light during operation.

NOTE: Never use steam to clean electrical parts.



HYSTER

Maintenance Schedule

Table 9. Maintenance Schedule (See Figure 27 and Figure 28) (Continued)

Item No.	Item	Shift	1000 hrs/ 6 mo	2000 hrs/ 1 yr	4000 hrs/ 2 yr	Procedure or Quantity	Specification
	Operator Presence System Check	X	X			Check Operation. Repair if Needed.	

NOTE 1: Perform maintenance after the first 100 hours or 2 months of service.

NOTE 2: Multipurpose grease with 2 to 4% Molybdenum Disulfide for normal operations.

NOTE 3: Recommended service intervals are based on a normal application in a clean environment. Applications involving contaminated environments such as high levels of airborne debris (dust and waste paper); chemical or abrasive compounds; poor ground conditions; intensive usage at high performance levels; or other abnormal conditions will require more frequent servicing. At your request, your **Hyster** dealer will advise you of the appropriate service intervals based on an application survey.

NOTE 4: Maximize life of surfaces by lubricating every 250 hours for first 1000 hours.

NOTE 5: Equalization charge is required approximately each month. See manufacturer's service instructions.

NOTE 6: Lubricate if dry or at first sign of visible surface rust.

NOTE 7: Multipurpose lithium base grease.

NOTE 8: This interval is for trucks working in a clean, dry warehouse-type operation. Trucks working in a more severe environment should reduce interval to 500 hours.

NOTE 9: Hydraulic oil sampling and analysis is a recommended practice. See **Hydraulic Cleanliness Procedures** 1900 SRM 1620 for oil cleanliness and water content guidelines. For lift trucks operating in heavy duty applications or highly contaminated environments, take oil samples every 500 hours. Normal operating conditions may allow for less frequent oil sampling. Oil sampling should be done just prior to all oil and filter changes.

X=Check C=Change L=Lubricate CIL=Check Indicator Light during operation.

NOTE: Never use steam to clean electrical parts.



Maintenance Procedures Every Shift

WARNING

DO NOT operate a lift truck that needs repairs. Report the need for repairs immediately. If repair is necessary, put a **DO NOT OPERATE** tag in the operator's area. Remove the key from the key switch.

Inspect the lift truck after every shift or daily before use. Put the lift truck on a level surface. Lower the carriage and forks and turn the key or keyless switch to the **OFF** position. Remove the floor mat and floor plate. Inspect for leaks and conditions that are not normal. Clean any oil spills. Make sure that lint, dust, paper, and other materials are removed from the compartments. Make the additional checks as described in the following paragraphs of **How to Make Checks With the Key or Keyless Switch OFF** and **How to Make Checks With the Key or Keyless Switch ON**.

How to Make Checks With the Key or Keyless Switch OFF

Wheels and Tires

Inspect the drive tires and wheel assemblies and the steer tire and wheel assemblies for damage. Look for deep grooves or cuts in the tires. Remove objects embedded in the tire, such as wire, rocks, glass, and pieces of metal that can cause damage. See **Figure 29**. Remove any wire, strapping, or other material that is wrapped around the axle to prevent damage to the transaxle seals. Inspect wheel rims for rust or cracks and check for loose or missing lug nuts and broken studs. **DO NOT** operate a lift truck with damage to any wheel rim, lug nuts, or studs.

HYSTER

Maintenance

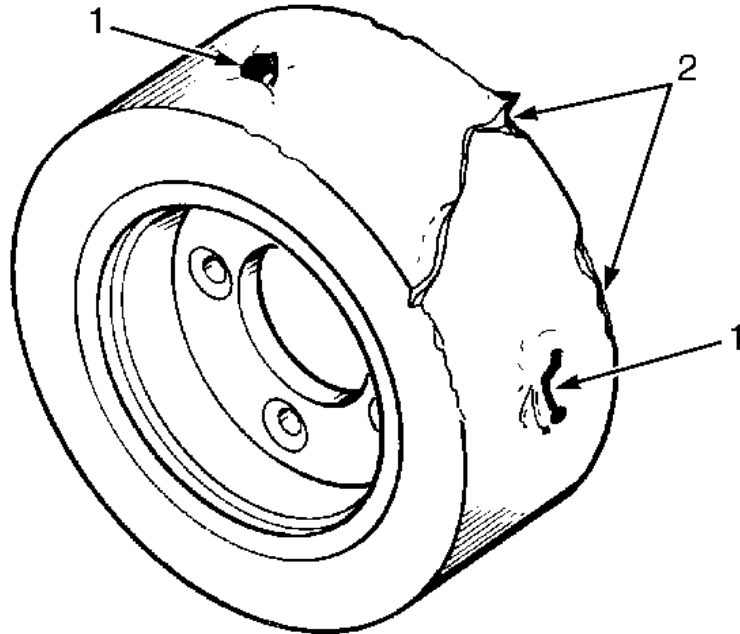

BO190155

1. CHECK FOR DAMAGE (REMOVE NAILS, GLASS, AND OTHER OBJECTS FROM THE TREAD)
2. MAKE SMOOTH EDGES

Figure 29. Tire Check

Safety Labels

WARNING

Safety labels are installed on the lift truck to provide information about possible hazards. It is important that

all safety labels are installed on the lift truck and can be read.

Check that all safety labels are installed in the correct locations on the lift truck. See the **Parts Manual** or the section **Frame 100 SRM 1329** of the **Service Manual** for the correct locations of the safety labels.

Check that the **Operating Manual** is not worn or damaged and replace it if necessary.

Frame and Covers

The frame is a single weldment with mounts for the counterweight, overhead guard, mast, steering system, hydraulic system, and transaxles. Check the condition of the frame, especially around welds, for rust, cracks, or other damage. The overhead guard must be free from defects to ensure protection to the operator. A variety of covers and floor plates provide protection and allow easy access to systems located inside and around the frame. See **Figure 30**. Make certain that all covers and floor plates are present and secured in their proper locations.

Maintenance

HYSTER

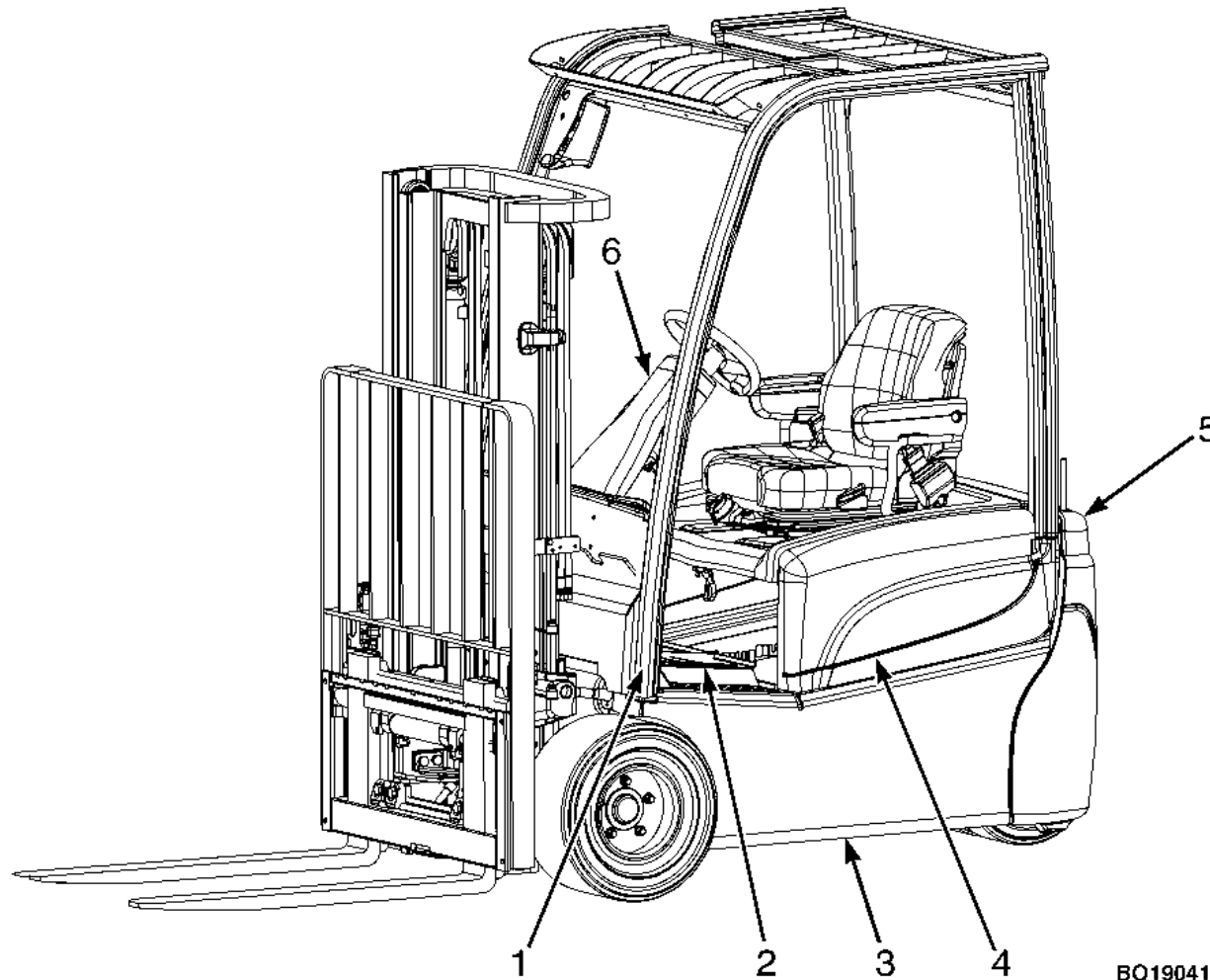

1. OVERHEAD GUARD
2. FLOOR PLATE
3. FRAME
4. HOOD SIDE COVER
5. COUNTERWEIGHT COVER
6. STEERING COLUMN COVER

BO190412

Figure 30. Frame and Covers Check



HYSTER

Maintenance

Forks, General

NOTE: Forks must be removed or installed by trained personnel only.

The identification of a fork describes how the fork is connected to the carriage. These lift trucks have hook forks.

Forks, Remove

NOTE: If lift truck is equipped with a fork positioner attachment, perform **Step 1** first, before going to **Step 2**. If lift truck is not equipped with a fork positioner attachment, go to **Step 2**.

1. Lower the carriage and remove four capscrews from inner fork carriers. Remove inner fork carriers from fork positioner. See **Figure 31**.

WARNING

DO NOT try to move a fork without a lifting device. The forks can weigh 45 to 115 kg (99 to 254 lb).

NOTE: Forks are to be replaced only in sets and not individually.

2. A fork can be removed from the carriage for replacement of the fork or other maintenance. Slide a hook fork to the fork removal notch on the carriage. See **Figure 32**. Lower the fork onto blocks so that the lower fork hook moves through the fork removal notch. See **Figure 33** and **Figure 35**. Lower the carriage further so that the top fork hook is disengaged from the top carriage bar. Move the carriage away from the fork, or use a lifting device to move the fork away from the carriage.

Maintenance

HYSTER

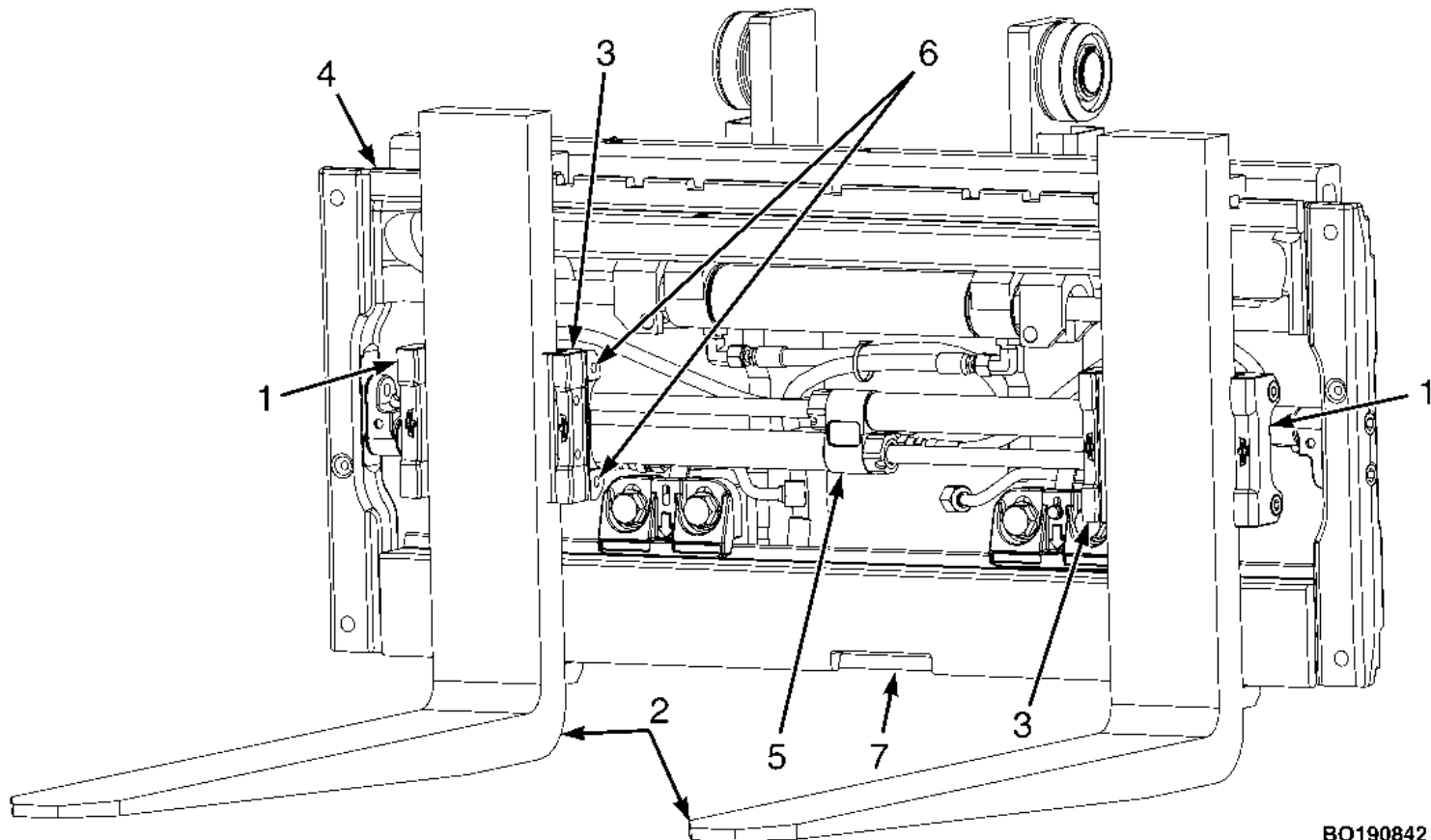

1. OUTER FORK CARRIER
2. FORKS
3. INNER FORK CARRIER
4. SIDESHIFT CARRIAGE
5. FORK POSITIONER
6. CAPSCREWS
7. FORK REMOVAL NOTCH

BO190842

Figure 31. Fork Positioner

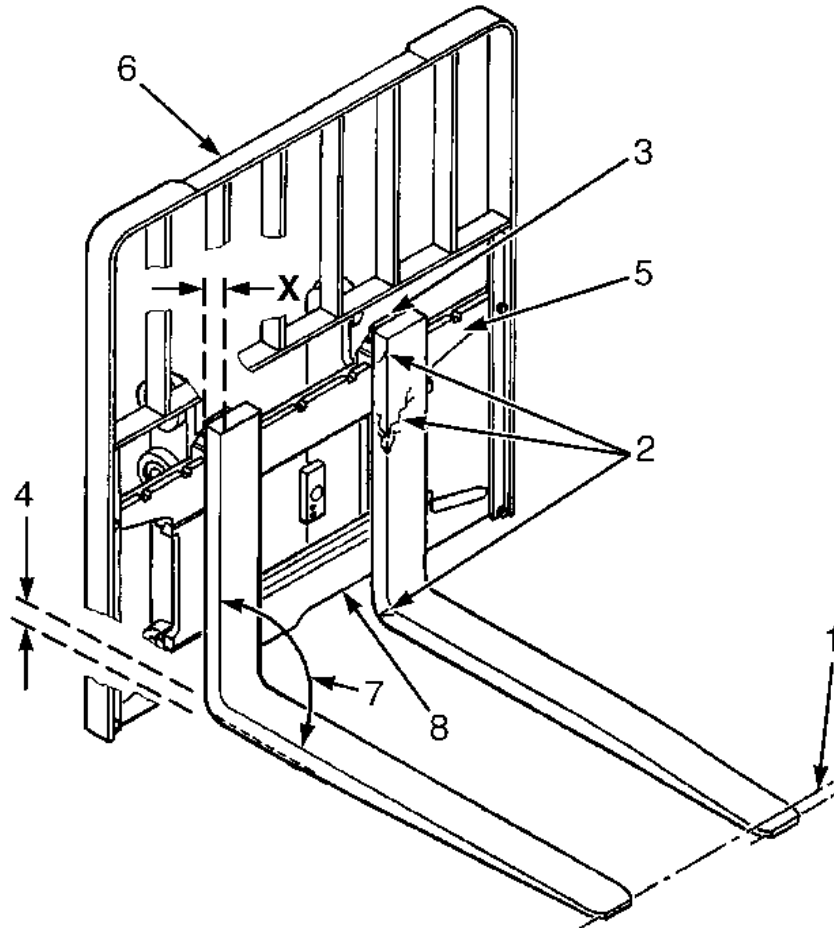

Fork Tip Alignment	
Length of Forks	3% Dimension
915 mm (36 in)	27 mm (1.10 in)
1067 mm (42 in)	32 mm (1.26 in)
1220 mm (48 in)	37 mm (1.46 in)
1372 mm (54 in)	41 mm (1.61 in)
1524 mm (60 in)	46 mm (1.81 in)
1830 mm (72 in)	55 mm (2.17 in)

1. TIP ALIGNMENT (MUST BE WITHIN 3% OF FORK LENGTH)
2. CRACKS
3. LATCH DAMAGE
4. HEEL OF FORK (MUST BE 90% OF DIMENSION "X")
5. CARRIAGE
6. LOAD BACKREST EXTENSION
7. MAXIMUM ANGLE 93°
8. FORK REMOVAL NOTCH

BO190157

Figure 32. Forks Check

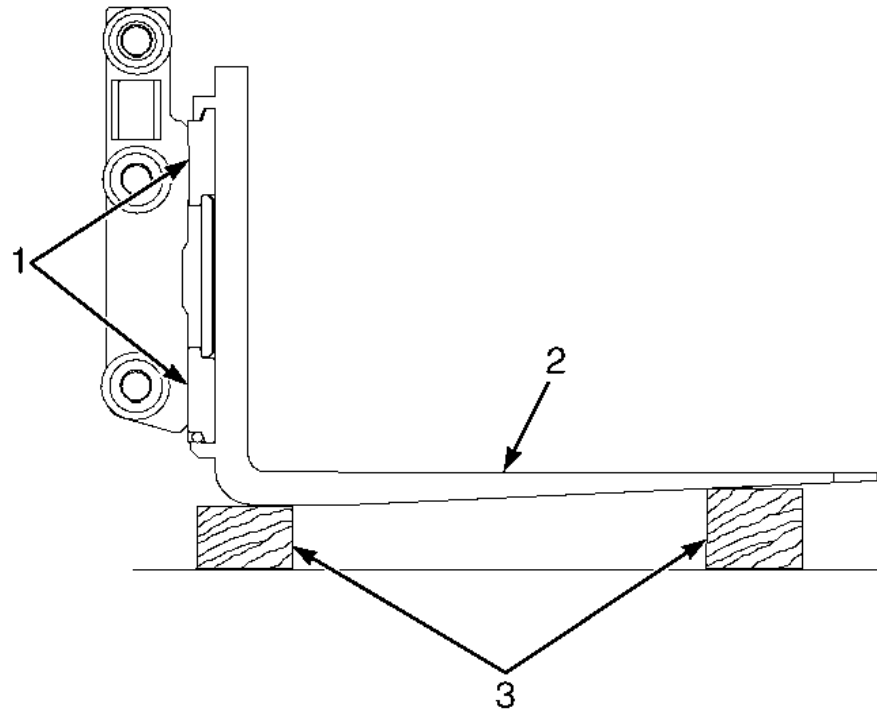

BO190824

1. CARRIAGE BARS
2. HOOK FORK
3. BLOCKS

Figure 33. Remove a Hook Fork

Forks, Inspect

WARNING

DO NOT try to correct fork tip alignment by bending the forks or adding shims. Replace bent forks.

Never repair damaged forks by heating or welding. Forks are made of special steel using special procedures. Replace damaged forks. Forks are to be replaced only in sets and not individually.

1. Inspect the forks for cracks and wear. Check that the fork tips are aligned as shown in **Figure 32**. Check that the bottom of the fork is not worn (item 4 in **Figure 32**).
2. Replace any damaged or broken parts that are used to keep the forks locked in position. See **Figure 35**.
3. Inspect fork wear. Ensure heel wear is not more than 10% of original thickness. If fork wear is more than 10%, fork must be replaced or rerated. Perform fork wear inspection using a BOL256N1 caliper ruler Hyster P/N 4092984 as follows. See **Figure 34**.

- a. Determine normal thickness of "N" of fork using scale or ruler portion of caliper ruler. Measurement has to be done on fork shank using caliper ruler.

HYSTER

Maintenance

b. Position caliper at end of heel internal radius (item 4, **Figure 32**) with opening corresponding to measured thickness of fork shank in **Step a** above. (e.g. for N 1.75 use N 1.75 opening). This is typically the section of fork where wear is greatest. Note that opening distance has been reduced by 10% from nominal thickness.

c. If fork enters opening, it is mandatory to replace it. **DANGER OF BREAKING.** Furthermore, a 10% reduction in fork blade thickness results in 20% reduction in operating capacity.

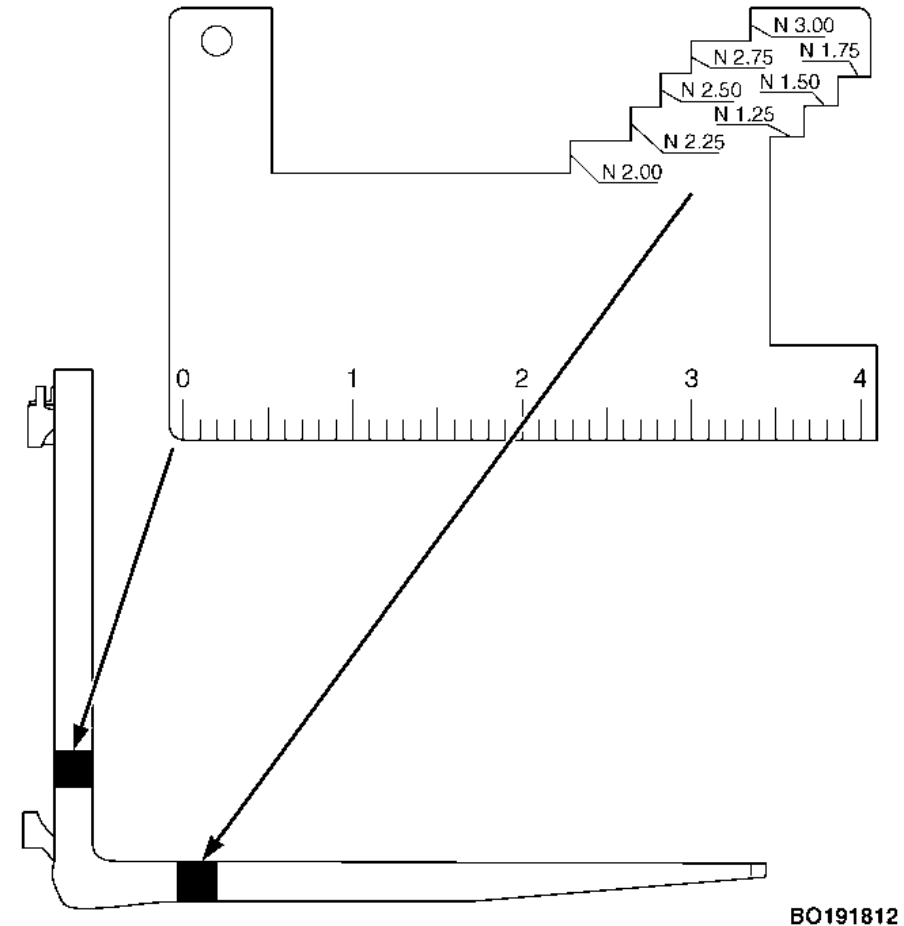

BO191812

Figure 34. Fork Wear Check

Maintenance

HYSTER

Forks, Install

WARNING

DO NOT try to move a fork without a lifting device. The forks can weigh 45 to 115 kg (99 to 254 lb).

1. Move the fork and carriage so that the top fork hook can engage the top carriage bar. Raise the carriage to move the lower fork hook through the fork removal notch. Slide the fork on the carriage so that both upper and lower fork hooks engage the carriage. Engage the lock pin with a notch in the top carriage bar. See **Figure 35**.

2. If lift truck is equipped with a fork positioner, install inner fork carriers using four capscrews. Tighten capscrews to 35 N•m (25 lbf ft). See **Figure 31**.

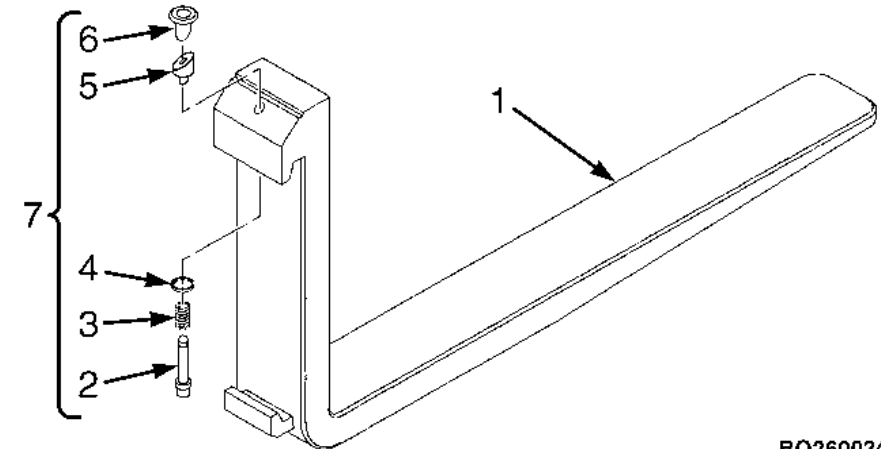

BO260034

1. FORK
2. LOCK PIN
3. SPRING
4. WASHER
5. WEDGE
6. KNOB
7. LOCK PIN ASSEMBLY

Figure 35. Fork Lock Pin Assembly



HYSTER

Maintenance

Forks, Adjust

NOTE: During the adjustment of the forks, the heel of the forks should not be touching the ground.

The forks are connected to the carriage by hooks and lock pins. See **Figure 35**. These lock pins are installed through the top fork hooks and fit into slots in the top carriage bar. Adjust the forks as far apart as possible for maximum support of the load. Hook forks will slide along the carriage bars to adjust for the load to be lifted. Raise the lock pin in each fork to slide the fork on the carriage bar. Make sure the lock pin is engaged in the carriage bar to lock the fork in position after the width adjustment is made.

Inspection of Mast, Carriage, Header Hoses, Lift Chains, and Attachments

WARNING

Lower the lift mechanism completely. Never allow any person under a raised carriage. DO NOT put any part of your body in or through the lift mechanism unless all parts of the mast are completely lowered and the lift truck motor is OFF.

1. Inspect the welds on the mast, cylinders, and carriage for cracks. Make sure that the capscrews and nuts are tight.
2. Inspect the channels for wear in the areas where the rollers travel. Inspect the rollers for wear or damage.
3. Check mast lubrication. If necessary, lubricate the sliding surfaces and the load roller surfaces along the full length of the channels as shown in **Figure 36**. Only apply lubricant to surfaces that are clean and dry. Only apply lubricant to the darker areas as indicated by (1) and (2) in **Figure 36**.
4. Inspect the load backrest extension for cracks and damage.
5. If the lift truck is equipped with a sideshift carriage or attachment, inspect the parts for cracks and wear. Make sure the parts that fasten the sideshift carriage or attachment to the carriage are in good condition.

Maintenance

HYSTER

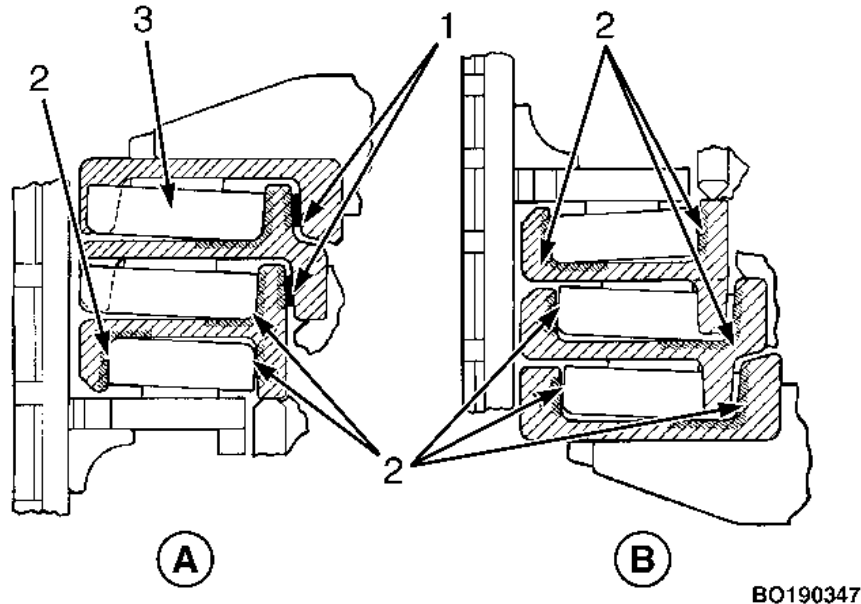

NOTE: MAST IS DIFFERENT, BUT LUBRICATION AREAS ARE THE SAME.

- A. UPPER LOAD ROLLERS
 - B. LOWER LOAD ROLLERS
1. LUBRICATE STRIP BEARINGS SURFACES
 2. LUBRICATE LOAD ROLLER SURFACES
 3. LOAD ROLLER

Figure 36. Mast Lubrication

⚠ WARNING

Always wear the proper protective equipment including eye protection and petroleum-resistant gloves when handling hydraulic oil. Thoroughly wash oil from exposed areas of skin as soon as possible.

⚠ WARNING

Never check for leaks by putting hands on hydraulic lines or components under pressure. Hydraulic oil under pressure can be injected into the skin.

6. Visually inspect hoses/fittings for hydraulic leaks; hose covers for cuts, cracks, or exposed reinforcement; defective/broken clamping devices or sheaves; and proper tracking during operation. Adjust/repair/replace hose/components as necessary.

7. Check that lift chains are correctly lubricated. Use SAE 30W engine oil to lubricate lift chains.

8. Inspect the lift chains for cracks or broken links and worn or turned pins. Lift chains must be replaced as a set. See **Figure 37**.

NOTE: Chain anchor pins **MUST** be replaced any time chains are replaced.

HYSTER

Maintenance

9. Inspect the chain anchors and pins for cracks and damage.

10. Make sure the lift chains are adjusted so that they have equal tension. **Adjustments or replacement of the lift chains must be done by authorized personnel.**

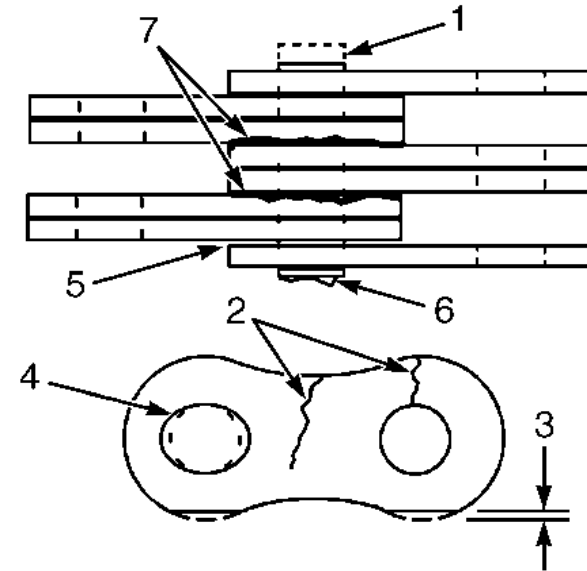

BO190158

1. WORN PIN
2. CRACKS
3. EDGE WEAR (MAXIMUM 5% OF NEW)
4. HOLE WEAR
5. LOOSE LEAVES
6. DAMAGED PIN
7. CORROSION

Figure 37. Check the Lift Chains



Maintenance

HYSTER

Hydraulic Oil Level and Leaks

WARNING

At operating temperature the hydraulic oil is **HOT**. **DO NOT** permit the oil to contact the skin and cause a burn.

WARNING

Always wear the proper protective equipment including eye protection and petroleum-resistant gloves when handling hydraulic oil. Thoroughly wash oil from exposed areas of skin as soon as possible.

CAUTION

DO NOT permit dirt to enter the hydraulic system when the oil level is checked or the filter is changed.

Never operate the pump without oil in the hydraulic system. The operation of the hydraulic pump without oil will damage the pump.

Inspect the hydraulic system for leaks and damaged or loose components. Heavy-duty or high-temperature operations can require more frequent checks.

Operator Restraint System

There is an indicator icon on the display panel for the seat belt. The icon is ON as described in the **Model Description** section of this manual. The indicator icon can help the operator remember to fasten the seat belt.

The seat belt, armrests, and the seat and mounting are the parts of the operator restraint system. See **Figure 38** and **Figure 39**. Each item must be checked to make sure it is attached securely, functions correctly, and is in good condition.

The seat belt must latch securely. Make sure the seat belt extends and retracts smoothly and is not damaged or torn. If the seat belt cannot be pulled from the belt housing, the seat belt assembly must be replaced. Keep the belt straight so that it pulls out and retracts smoothly.

Make sure the seat rails are not loose. See **Figure 39**. The seat rails must lock securely in position, but move freely when unlocked. The seat rails must be securely attached to the mounting surface.

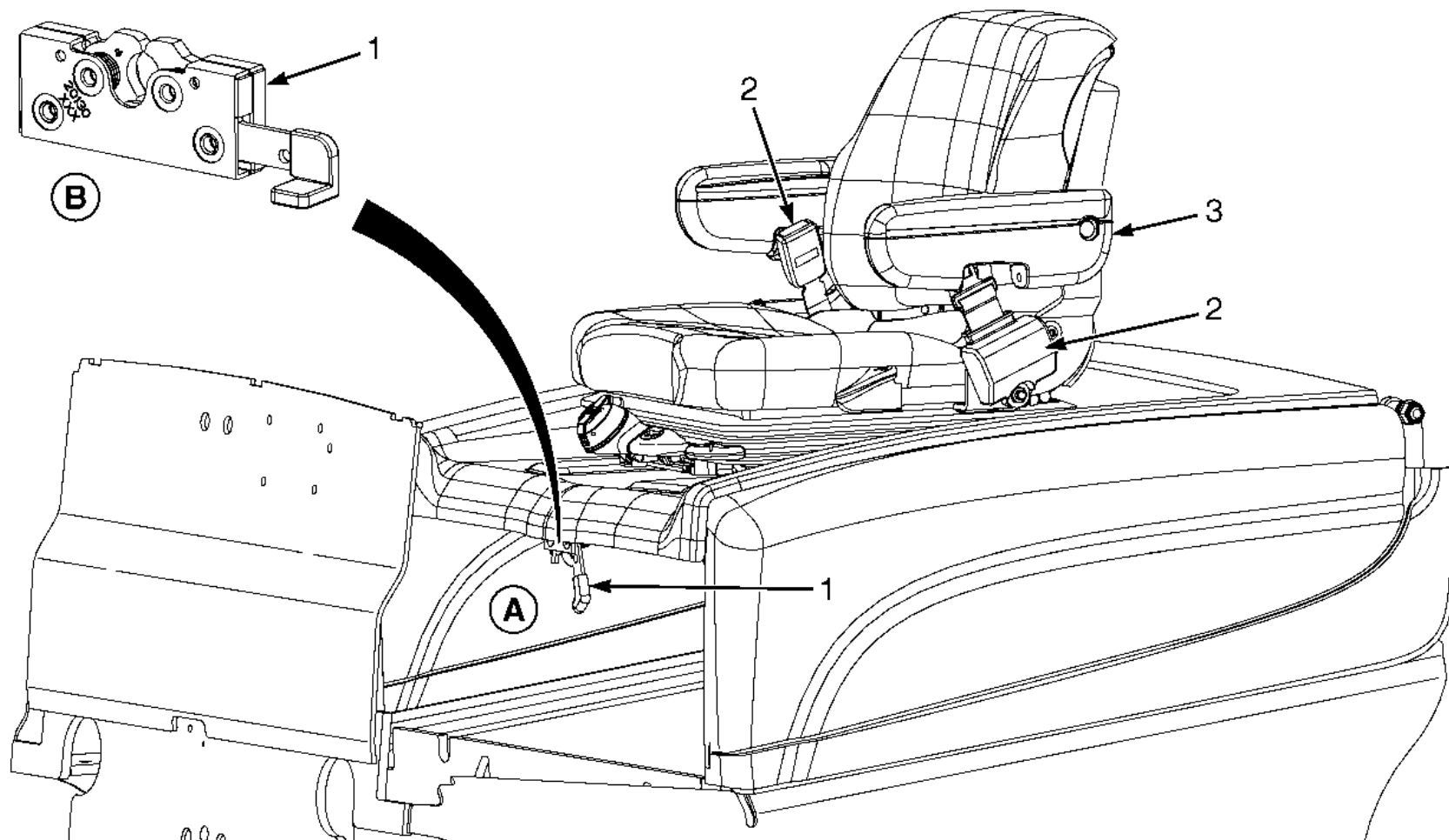

BO191143

Figure 38. Operator Restraint System



Maintenance

HYSTER

Legend for Figure 38

- A. HOOD LATCH ASSEMBLY, LIFT TRUCKS MANUFACTURED BEFORE MARCH, 2015
 - B. HOOD LATCH ASSEMBLY, LIFT TRUCKS MANUFACTURED AFTER FEBRUARY, 2015
- 1. HOOD LATCH HANDLE
 - 2. SEAT BELT
 - 3. ARMRESTS

Emergency Locking Retractor (ELR)

When the ELR style seat belt is properly buckled across the operator, the belt will permit slight operator repositioning without activating the locking mechanism. If the truck tips over, travels off a dock, or comes to a sudden stop, the locking mechanism will be activated and hold the operator's lower torso in the seat. See **Figure 38** and **Figure 39**.

A seat belt that is damaged, worn, or does not operate properly will not provide protection when it is needed. The end of the belt must fasten correctly in the latch. The seat belt must be in good condition. Replace the seat belt if it is damaged or worn.

The following seat belt operation checks must be performed three times before replacing the seat belt assembly:

- With the hood closed and in the locked position, pull the seat belt slowly from the retractor assembly. Make sure

the seat belt pulls out and retracts smoothly. If the seat belt does not pull out of the retractor assembly the internal latch may be locked. Pull firmly on the seat belt and hold for a moment to remove slack from the belt in the retractor. Release the seat belt. Seat belt will retract and the internal latch will unlock. If the seat belt cannot be pulled from the retractor assembly or the belt will not retract, replace the seat belt assembly.

- With the hood closed and in the locked position, pull the seat belt with a sudden jerk. Make sure the seat belt will not pull from the retractor assembly. If the seat belt can be pulled from the retractor when it is pulled with a sudden jerk, replace the seat belt assembly.
- With the hood in the open position, make sure the seat belt will not pull from the retractor assembly. If the seat belt can be pulled from the retractor, with the hood in the open position, replace the seat belt assembly.

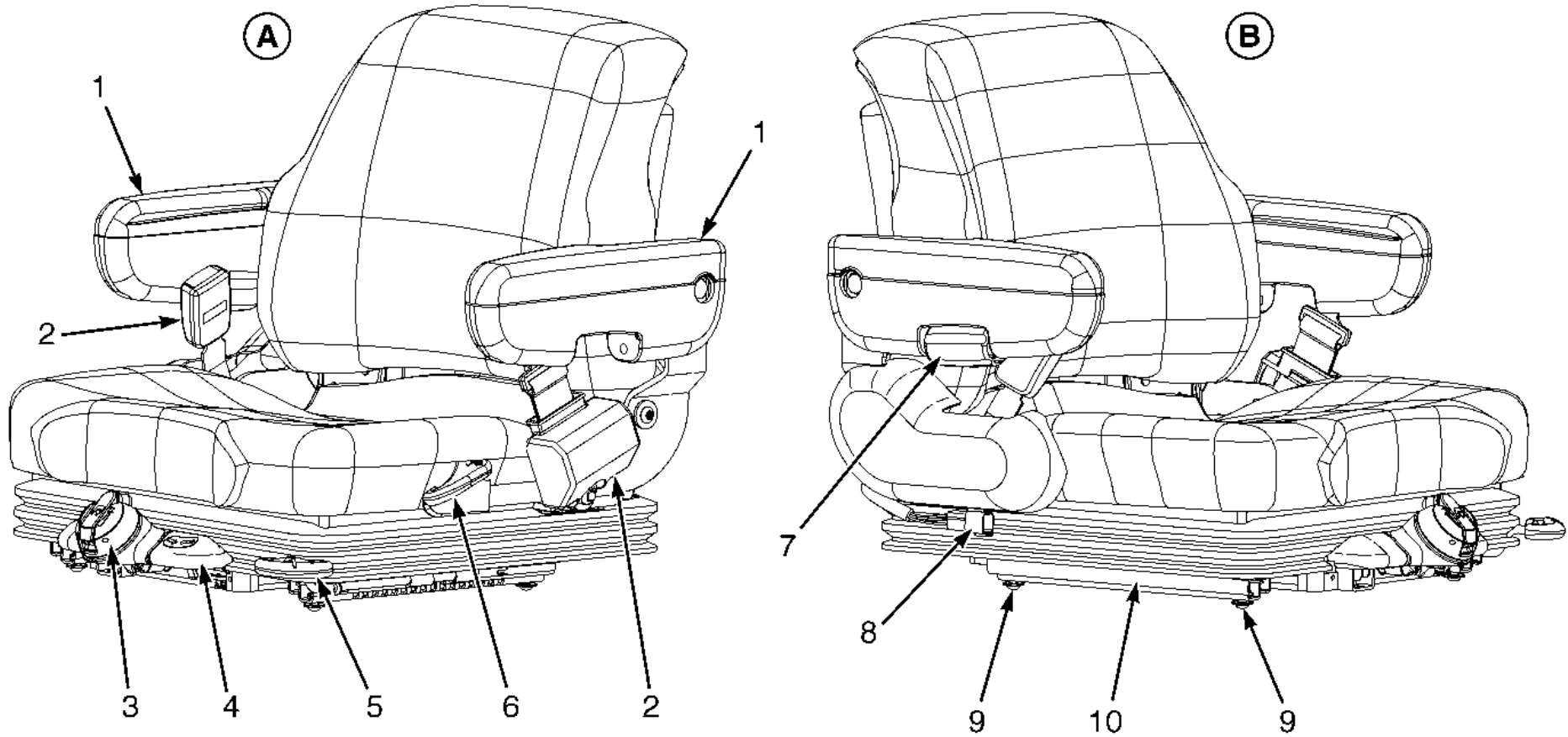

BO190416

Figure 39. Seat Components



Maintenance

HYSTER

Legend for Figure 39

NOTE: FULL SUSPENSION, NON-SWIVEL SEAT SHOWN. AN OPTIONAL SWIVEL SEAT IS AVAILABLE. SWIVEL SEAT ARRANGEMENT IS THE SAME. MANUAL HYDRAULIC ARMRESTS SHOWN.

A. LEFT VIEW

1. ARMRESTS
2. SEAT BELT
3. WEIGHT ADJUSTMENT KNOB
4. RIDE POSITION INDICATOR
5. FORWARD/BACKWARD ADJUSTMENT LEVER

B. RIGHT VIEW

6. BACKREST ANGLE ADJUSTMENT LEVER
7. ARMREST BRACKET KNOB
8. SEAT HARNESS
9. MOUNTING HARDWARE
10. SEAT RAIL

Battery Restraint System

The Battery Restraint System is designed to hold the battery within the battery compartment if a tipover occurs. The battery restraint system contains a front spacer plate, a battery plate, front and rear bulkheads, and the left and right frame plates. Lift trucks with a 750mm battery compartment may also have a spacer block to help prevent the battery from moving. See **Figure 40**, **Figure 41**, **Figure 42**, **Figure 43**, and **Figure 44**.

The hood and hood latch mechanism also help keep the battery within the battery compartment if a tipover occurs. The hood can be raised for access to the battery. A gas spring helps raise and hold the hood in the up position.

The battery restraint system must function so that the operator restraint system can operate correctly. Operation of the battery restraint system requires that the maximum movement allowed for the battery is 13 mm (0.5 in.) in any horizontal direction. This will reduce the risk of operator injury in a truck tipover. An adjustable front battery spacer plate prevents the front-to-back movement of the battery. Batteries for this series of lift trucks must all have the same length dimension to just fit the battery compartment width. For correct battery sizes, see the **Battery Specifications** in the back of this manual.

HYSTER

Maintenance

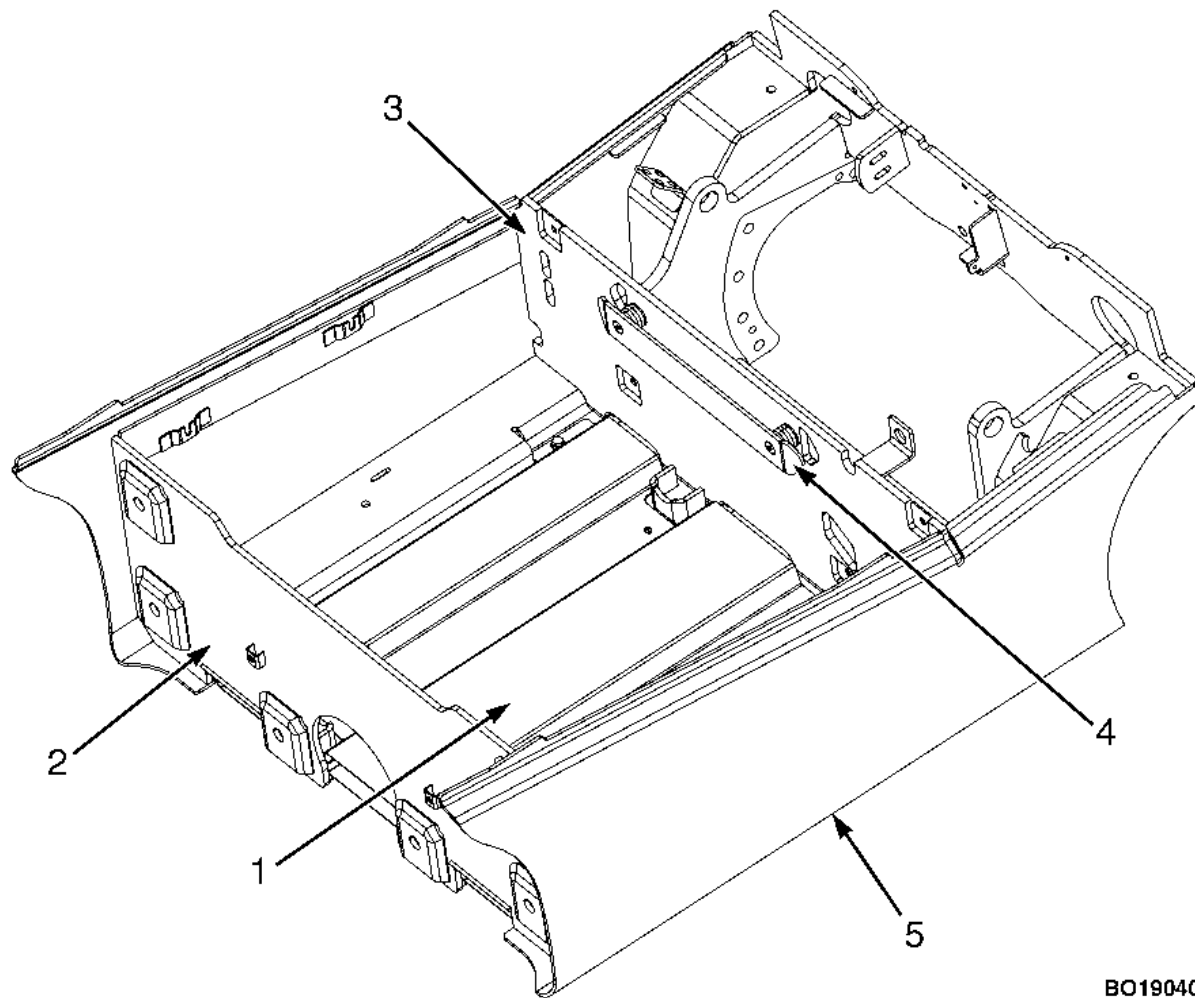

- 1. BATTERY PLATE
- 2. REAR BULKHEAD
- 3. FRONT BULKHEAD
- 4. FRONT SPACER PLATE
- 5. RIGHT FRAME PLATE

BO190406

Figure 40. Standard Battery Restraint System

Maintenance

HYSTER

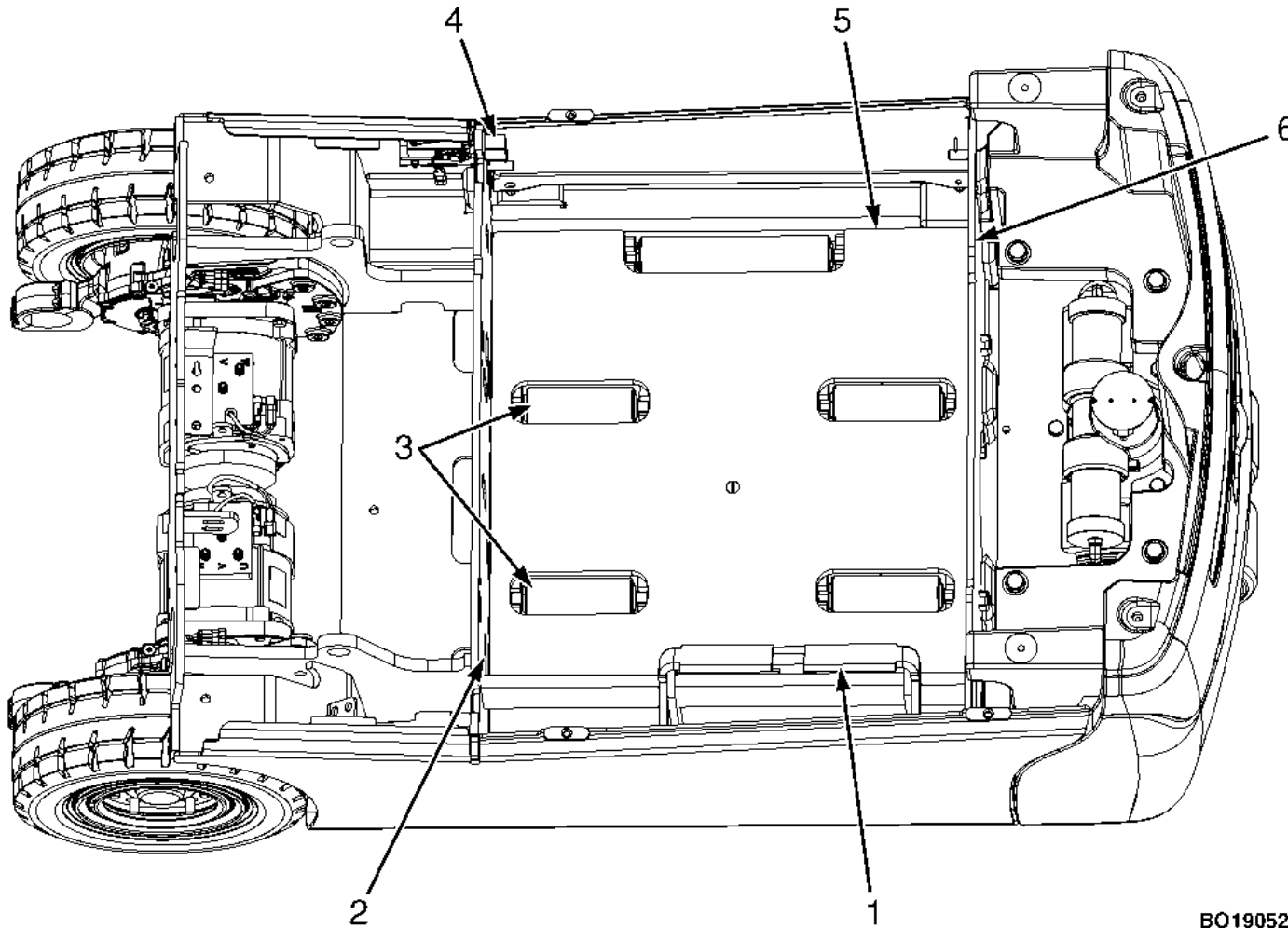

NOTE: 750 MM BATTERY COMPARTMENT SHOWN.

1. SPACER BLOCK
2. FRONT BULKHEAD
3. ROLLERS
4. BATTERY RESTRAINT BAR
5. BATTERY PLATE
6. REAR BULKHEAD

BO190521

Figure 41. Optional Battery Restraint System With Side Rollers, Lift Trucks Manufactured Before March, 2015

HYSTER

Maintenance

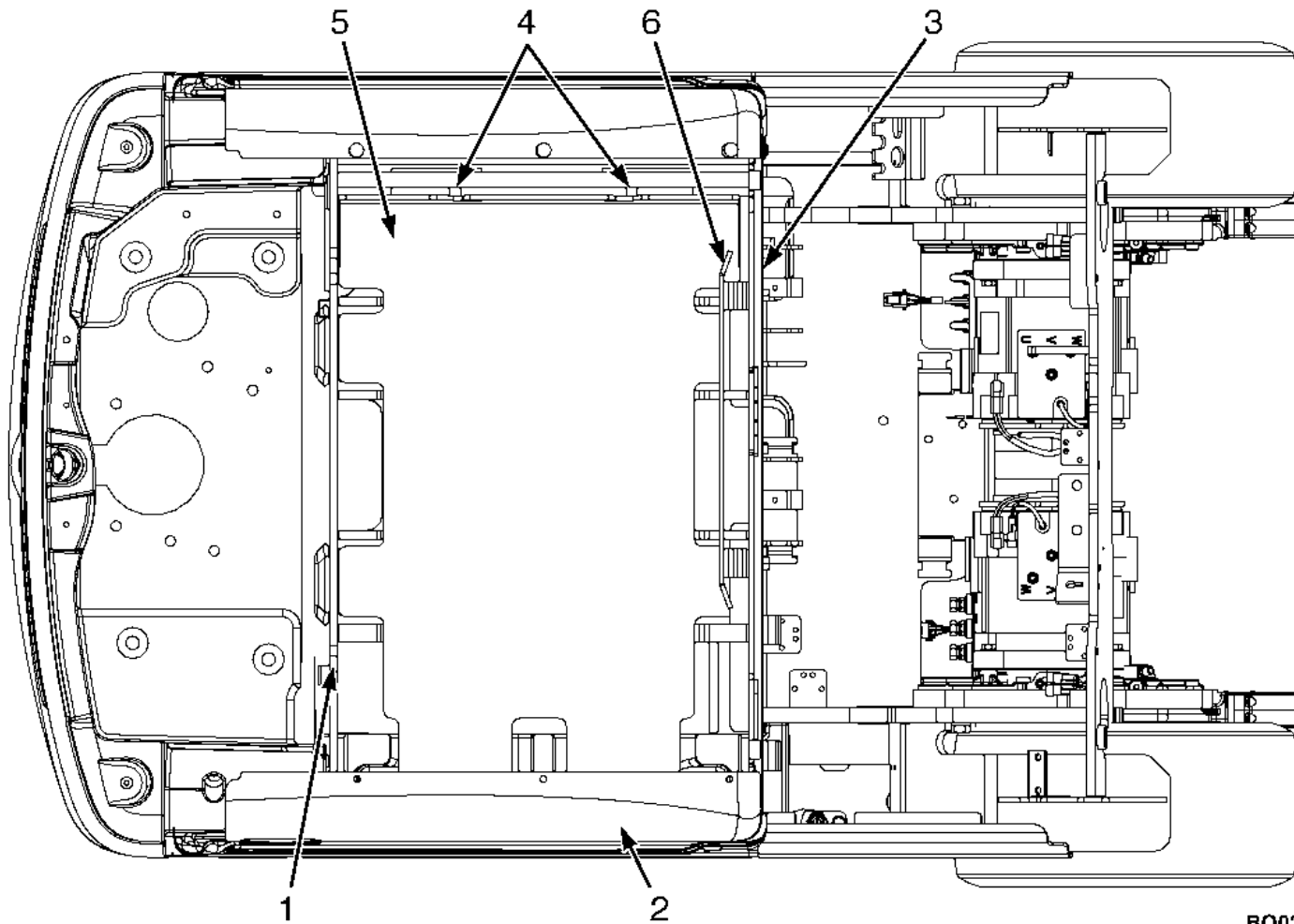

1. REAR PLATE
2. 180-DEGREE HINGED BATTERY REMOVAL DOOR
3. FRONT BULKHEAD
4. BATTERY SPACER
5. BATTERY TRAY
6. FRONT SPACER PLATE

BO030008

Figure 42. Optional Removable Battery Tray, Lift Trucks Manufactured After February, 2015

Maintenance

HYSTER

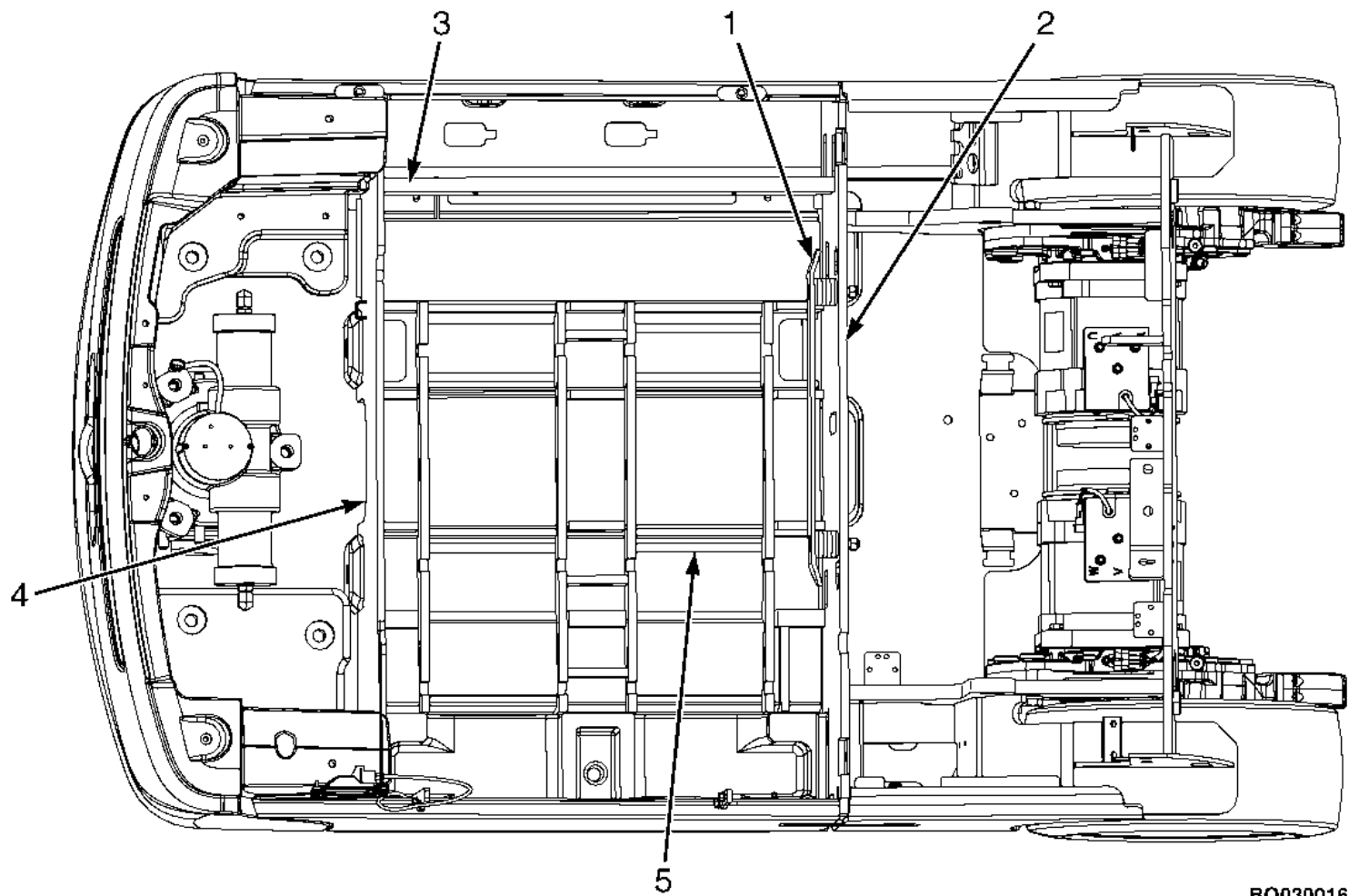

1. FRONT SPACER PLATE
2. FRONT BULKHEAD
3. BATTERY RESTRAINT BAR
4. REAR BULKHEAD

B0030016

Figure 43. Optional Battery Tray Used With Battery Exchange Stacker

HYSTER

Maintenance

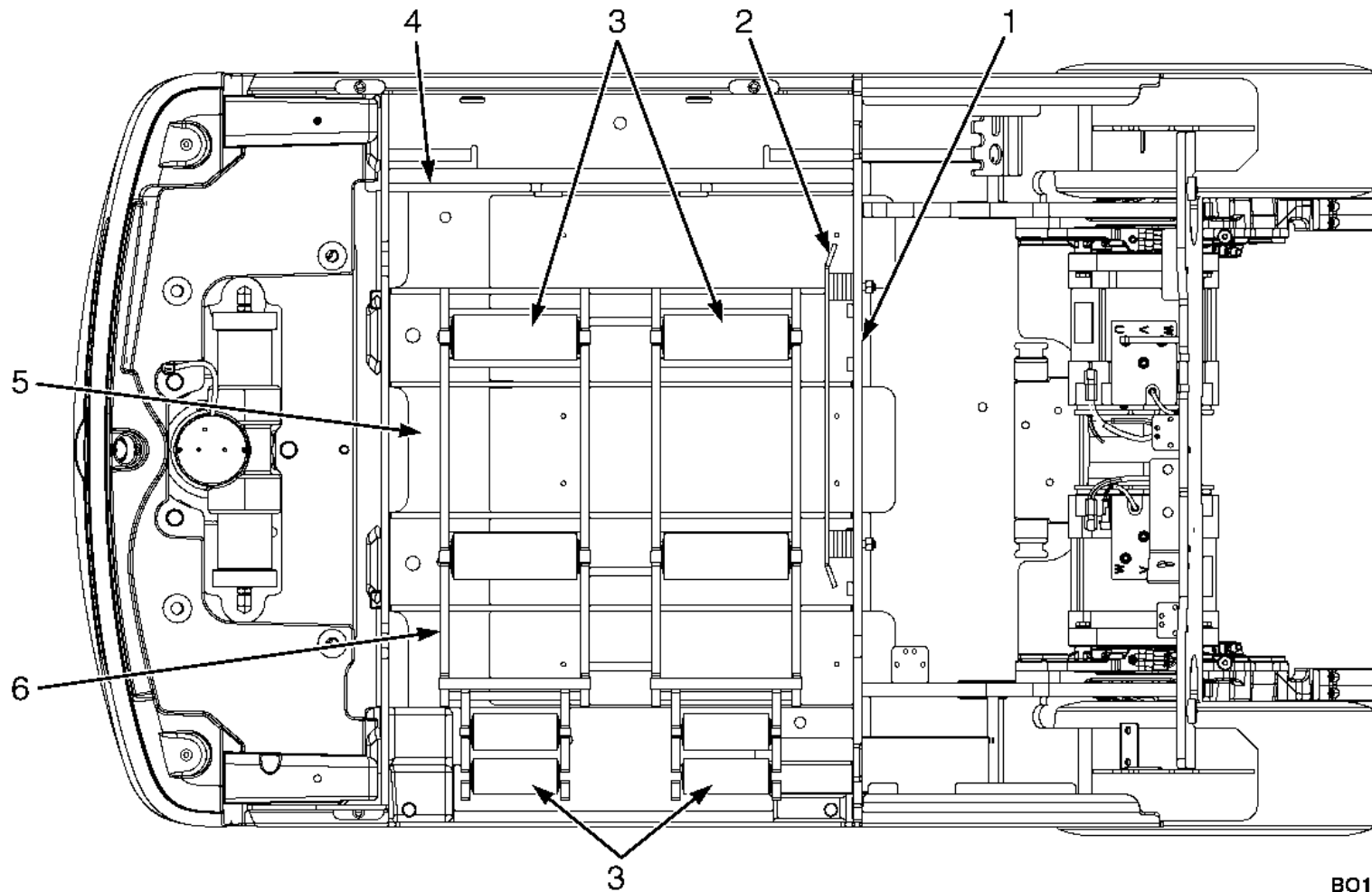

1. FRONT BULKHEAD
2. FRONT SPACER PLATE
3. ROLLERS
4. BATTERY RESTRAINT BAR
5. BATTERY PLATE
6. REAR BULKHEAD

BO191140

Figure 44. Optional Battery Restraint System with Side Rollers, Lift Trucks Manufactured After February, 2015



Maintenance

HYSTER

To raise the hood, perform the following:

1. Use the tilt memory lever and tilt the steering column all the way up.
2. Slide the seat all the way back. For lift truck equipped with Rapid/Fast Charging, slide the seat all the way forward. If necessary, move the armrest all the way back if lift truck is equipped with E-Hydraulic control levers.
3. If lift truck is equipped with manual hydraulic levers, release the latch for the control lever assembly and move the assembly to the forward position before raising the hood. See **Table 1**.

Lift Trucks Manufactured Before March, 2015

From the left side of the lift truck, push the hood release lever out toward the right side of the truck to unlatch the hood. Place hand on the hood handle on left side of the hood, and raise hood to the UP position. See **Figure 45**.

To close hood, lower the hood to the DOWN position and pull the hood release lever toward right side of the truck

and release to lock, it should click twice. Try to lift the hood to make sure the hood is fastened correctly.

The hood must be locked in the down position during lift truck operation. The battery must have the front and side spacer plates correctly adjusted to prevent any horizontal movement of more than 13 mm (0.50 in.).

Lift Trucks Manufactured After February, 2015

To open the hood, push hood release lever up to unlatch the hood. Place one hand in the plastic handle on the hood and the other hand on the hood latch and raise hood to the UP position. See **Figure 46**.

To close hood, lower the hood until the latch clicks once. Try to lift the hood to make sure the hood is locked down.

The hood must be locked in the down position during lift truck operation. The battery must have the front and side spacer plates correctly adjusted to prevent any horizontal movement of more than 13 mm (0.50 in.).

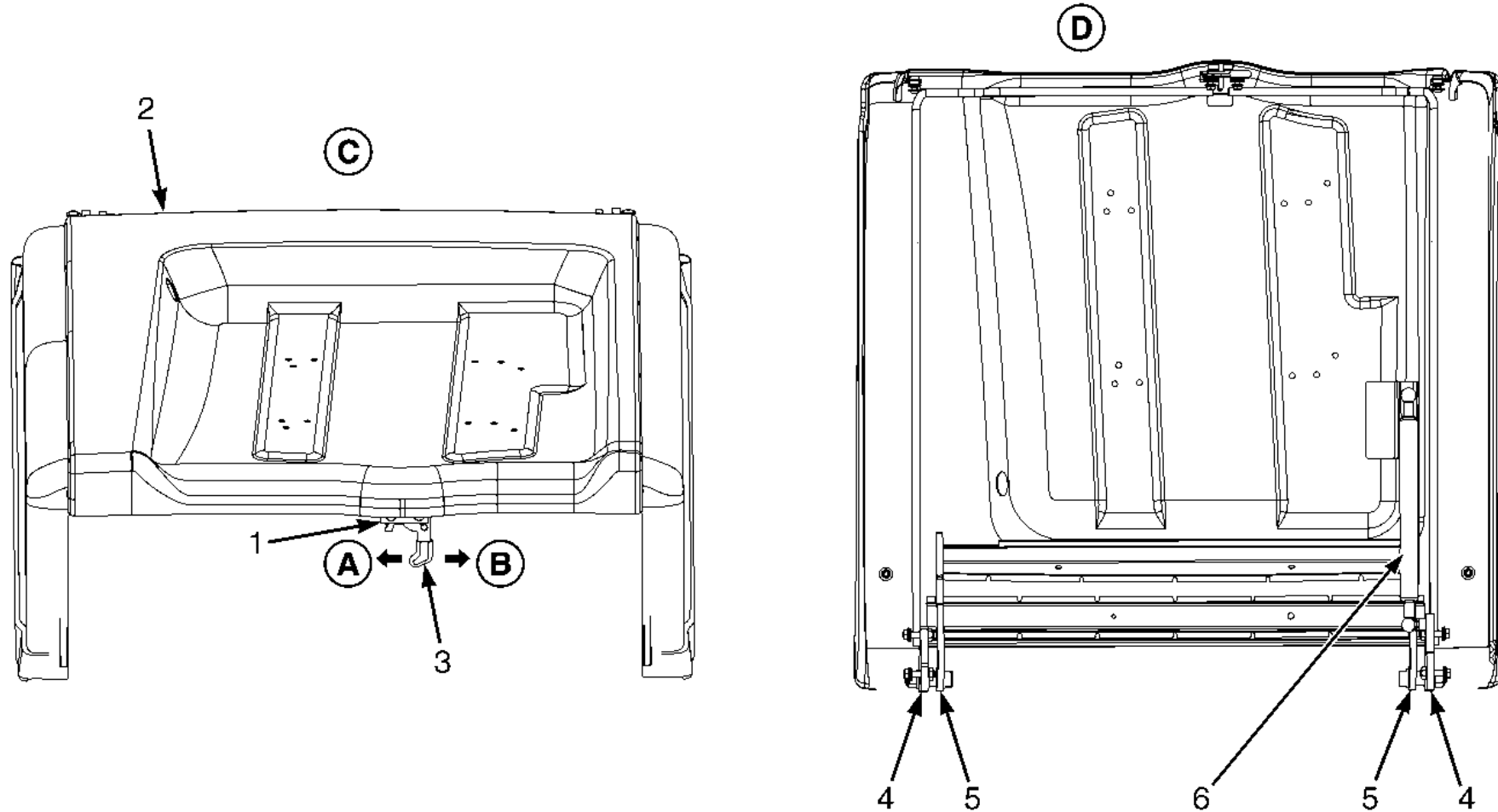

BO190417

Figure 45. Hood and Hood Latch Components, Lift Trucks Manufactured Before March, 2015



Maintenance

HYSTER

Legend for Figure 45

- | | | | |
|-----------|--------------------|-----------|-----------------------|
| A. | CLOSED POSITION | C. | FRONT VIEW |
| B. | OPEN POSITION | D. | BOTTOM VIEW |
| 1. | LATCH ASSEMBLY | 4. | HOOD MOUNTING BRACKET |
| 2. | HOOD | 5. | HOOD HINGE |
| 3. | HOOD RELEASE LEVER | 6. | GAS SPRING |

HYSTER

Maintenance

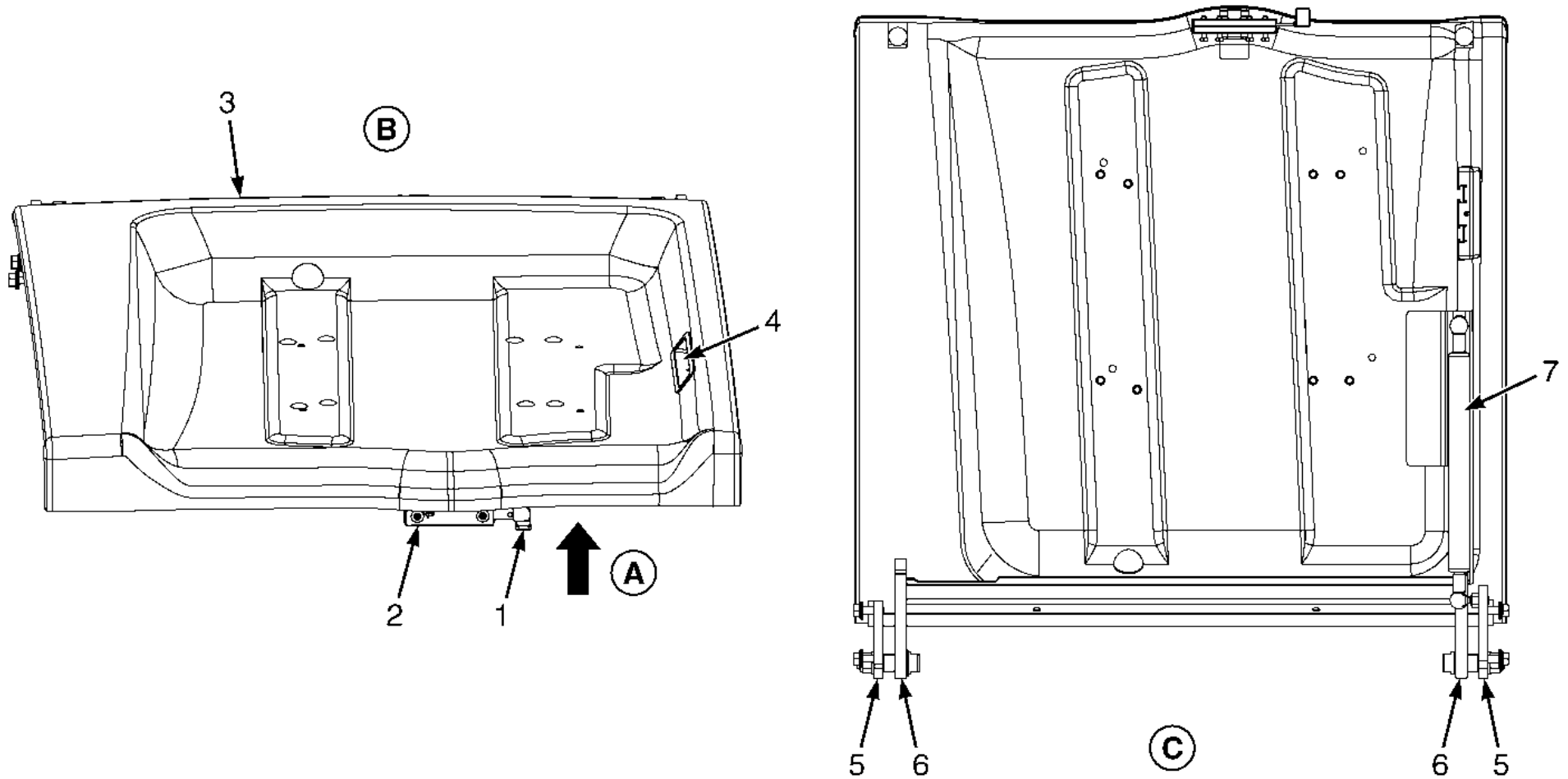

BO191148

Figure 46. Hood and Hood Latch Components, Lift Trucks Manufactured After February, 2015



Maintenance

HYSTER

Legend for Figure 46

- | | |
|--|--|
| <p>A. RELEASE DIRECTION</p> <p>B. FRONT VIEW</p> <p>1. HOOD RELEASE LEVER</p> <p>2. HOOD LATCH ASSEMBLY</p> <p>3. HOOD</p> <p>4. HOOD HANDLE</p> | <p>C. BOTTOM VIEW</p> <p>5. HOOD MOUNTING BRACKET</p> <p>6. HOOD HINGE</p> <p>7. GAS SPRING</p> |
|--|--|

Steering Column Adjustments

Make sure the steering column adjustment features are functioning properly. If lift truck is equipped with the

optional telescoping steering column, make sure the tilt memory and telescoping features are operating correctly. The tilt memory lever must **NOT** allow the column to move unless the tilt memory lever is released. See **Figure 47**.

HYSTER

Maintenance

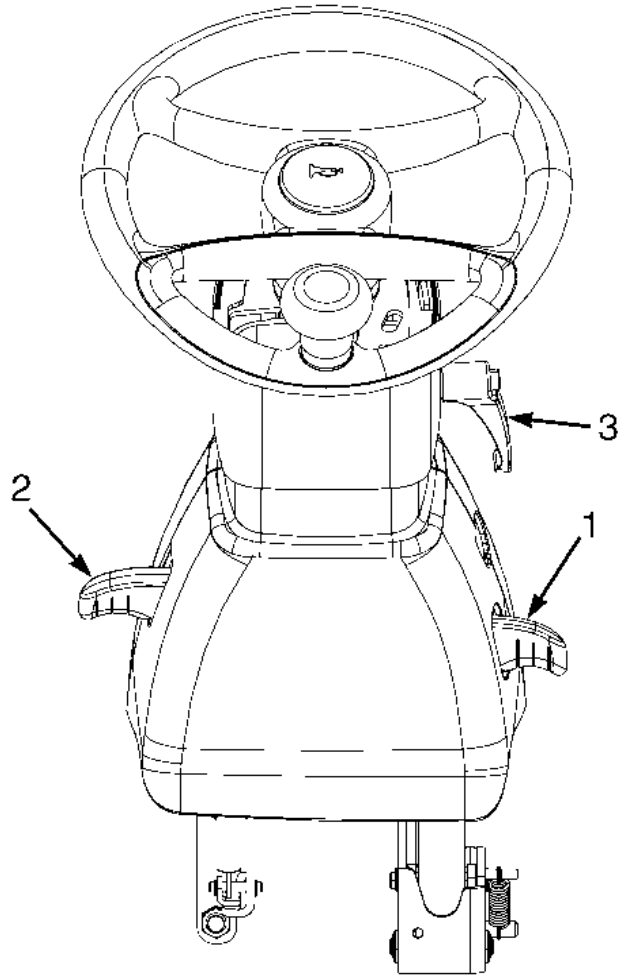

NOTE: OPTIONAL TELESCOPIC STEERING COLUMN SHOWN.

1. TILT POSITION LEVER
2. TILT MEMORY LEVER
3. TELESCOPIC COLUMN LOCKING HANDLE

BO190518

Figure 47. Steering Column Tilt Memory Lever



Maintenance

HYSTER

Tilt Adjust Feature

The column tilt angle should be locked in position whenever the steering column tilt position lever is released. Use multipurpose grease as shown in the **Maintenance Schedule** and lubricate the lever and pivots as needed.

NOTE: DO NOT use multipurpose grease to lubricate the sliding surfaces of the telescopic column.

Tilt Memory Feature

After the tilt memory lever is released, tilt the column down until the column locks into position. The column should remain locked in place and **NOT** move. Use multipurpose grease as shown in the **Maintenance Schedule** and lubricate the lever and pivots as needed.

Telescopic Feature

When the telescopic column locking handle is tightened to 6 N•m (53 lbf in), the steering wheel should remain locked in place. Use multipurpose grease as shown in the **Maintenance Schedule** and lubricate the lever and pivots as needed.

Battery Check

WARNING

Never put tools or other metal on the battery. Metal on the battery can cause a short circuit and possible damage or injury.

The acid in the electrolyte can cause injury. If the electrolyte is spilled, use water to flush the area. Make the acid neutral with a solution of sodium bicarbonate (soda). Acid in the eyes must be flushed with water immediately.

Batteries generate explosive fumes. Keep the vents in the caps clean. Keep sparks or open flames away from the battery area. DO NOT make a spark from the battery connections.

Disconnect the battery when doing maintenance.

NOTE: There can be one of two types of batteries. One type has removable cell caps. The other type has sealed cells. The sealed batteries require a different charger, the electrolyte level or specific gravity cannot be checked and water cannot be added to the electrolyte.



HYSTER

Maintenance

Make sure that the voltage and the weight of the battery are correct as shown on the Nameplate. See **Table 10** to check for correct battery dimensions.

Keep the battery case and the area for the battery clean and painted. Leakage from the battery and corrosion can cause a malfunction in the electric controls of the lift truck. Use a water and sodium bicarbonate (soda) solution to clean the battery and the battery area. Keep the top of the battery clean, dry and free of corrosion.

Make sure the battery is charged and has the correct voltage and ampere hour rating for the lift truck. See the Nameplate.

Inspect the battery case, connector and cables for damage, cracks or breaks. See the battery dealer in the area to repair any damage.

On batteries with cell caps, check the level of the electrolyte daily on a minimum of one cell. Add only distilled water, as necessary, to all cells that do not have the correct electrolyte level. The correct level is halfway between the top of the plates and the bottom of the fill hole.

How to Make Checks With the Key or Keyless Switch ON

WARNING

FASTEN YOUR SEAT BELT! The seat belt is installed to help the operator stay on the truck if the lift truck tips over. **IT CAN ONLY HELP IF IT IS FASTENED.**

After completing the **How to Make Checks With the Key or Keyless Switch OFF**, perform the **How to Make Checks With the Key or Keyless Switch ON** before placing the lift truck into service.

Make sure the area around the lift truck is clear before moving the lift truck. Be careful when making the checks.

Control Levers and Pedals

Check that the levers for the mast and attachment operate as described in **Model Description** section of this manual. The brake pedals are checked as described in the **Service Brakes** and **Automatic Parking Brake** paragraphs with the operation of the brakes.



Maintenance

HYSTER

Direction and Speed Control Pedals

Check that the direction and speed control pedals operate as described in the **Model Description** section of this manual.

Electrical Components

1. Check the operation of the horn by pressing the horn button on the steering wheel. The horn will operate when the key or keyless switch is in any position. If lift truck is equipped with E-Hydraulic controls, there is another horn button located on the armrest. See **Figure 8**, **Figure 9**, and **Table 1**.

There is also a handle with an optional horn button on the right overhead guard leg. See the **Model Description** section and **Table 1**.

2. If lift truck is equipped with lights, check the operation of the lights using the appropriate rocker switch, located to the right of the steering column. See **Figure 8**, **Figure 9**, and **Table 1**. The lights will operate when the key or keyless switch is in any position.

3. Check the strobe light by turning the key or keyless switch to the **ON** position and checking the operation of the

light. The strobe light can also be operated with a rocker switch.

4. Check the backup alarm on lift trucks equipped with a direction control switch. Sit in the seat, turn the key or keyless switch to the **ON** position, press the brake pedal and push down on the direction control switch to put it in reverse to sound the alarm.

5. Check the backup alarm on lift trucks equipped with a MONOTROL pedal by sitting in the seat, turning the key or keyless switch to the **ON** position, pressing the brake pedal, and pressing the reverse arrow on the MONOTROL pedal.

6. The display panel, located in the upper right corner of the operator's compartment (see **Figure 8** and **Figure 9**), is also energized when the key or keyless switch is turned to the **ON** position. The display is essential to safe and productive operation of the lift truck. Systems such as the battery condition and fault codes are monitored by the controller and are expressed by the display. A malfunctioning display unit may not alert an operator to a condition in time to prevent damage to system components on the lift truck.

HYSTER

Maintenance

In the event of an emergency, the emergency disconnect switch may be used to cut off power and automatically apply the park brake. To test that this switch is working properly, turn the key or keyless switch to the **ON** position. The operator can disconnect all electrical power to the lift truck by pushing the emergency disconnect switch in until it clicks. To reset (re-connect) the emergency disconnect switch and energize the electrical circuits, the operator must turn the switch clockwise until it pops up. See **Figure 48**.

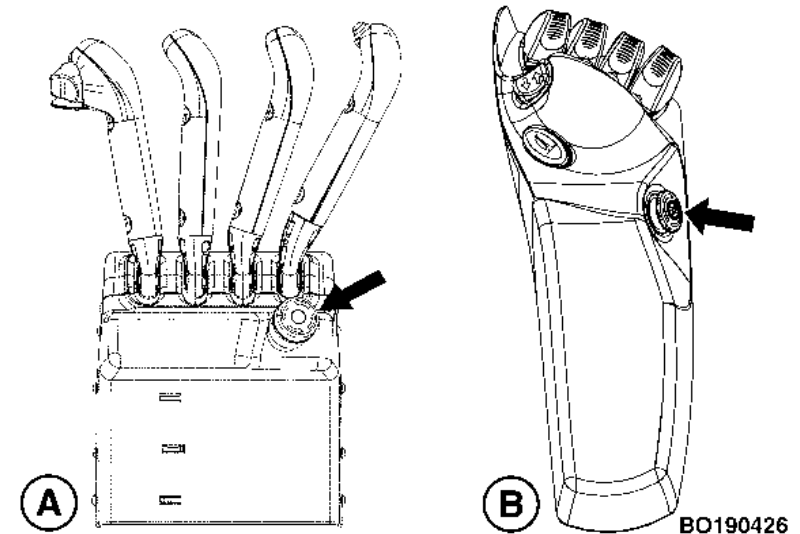

- A. MANUAL HYDRAULIC LEVERS
- B. E-HYDRAULIC MINI-LEVERS

Figure 48. Emergency Disconnect Switch

Steering System

The steering system should operate when a properly charged battery is connected, an operator is present in the seat, and the key or keyless switch is in the **ON** position. Move the steering tire and wheel assembly completely to the left by turning the steering wheel. The assembly should turn smoothly to its stop. The steering tire should stop approximately parallel to the battery. Turn the steering tire



Maintenance

HYSTER

and wheel assembly completely to its right hand stop using the steering wheel. The steering system should move smoothly and make a full range of motion from its full left to full right position (approximately 180 degrees).

Hydraulic System

WARNING

At operating temperature the hydraulic oil is **HOT**. **DO NOT** permit the oil to contact the skin and cause a burn.

WARNING

Always wear the proper protective equipment including eye protection and petroleum-resistant gloves when handling hydraulic oil. Thoroughly wash oil from exposed areas of skin as soon as possible.

CAUTION

DO NOT permit dirt to enter the hydraulic system when the oil level is checked or the filter is changed.

Never operate the pump without oil in the hydraulic system. The operation of the hydraulic pump without oil will damage the pump.

NOTE: Some parts of the mast move at different speeds during raising and lowering.

Slowly raise and lower the mast several times without a load. The mast components must raise and lower smoothly in the correct sequence. The carriage raises first, then the inner weldment and intermediate weldment (three-stage masts only).

The inner and intermediate weldments and the carriage must lower completely.

Raise the forks 1 m (3 ft) with a capacity load. The inner weldment and carriage must raise smoothly. Lower the forks. All moving components must lower smoothly.

With the load lowered, tilt the mast backward and forward. The mast must tilt smoothly and both tilt cylinders must stop evenly.

Check that the controls for the attachment operate the functions of the attachment. See the symbols by each of the controls as shown in **Table 4**. Make sure all of the hydraulic lines are connected correctly and do not leak.



HYSTER

Maintenance

Service Brakes

WARNING

Loss of fluid from the brake fluid reservoir indicates a leak. Repair the brake system before using the lift truck. Replace the brake fluid in the system if there is dirt, water, or oil in the system.

NOTE: Lift truck models J1.5-2.0XNT (K160) manufactured after February, 2016 are equipped with an Electronic Brake system (E-Brake) and do not use brake fluid.

There is an indicator icon on the display panel for the brake fluid level. The icon is illuminated as described in the **Model Description** section of this manual. If the icon is illuminated during operation, the fluid in the reservoir for the brake master cylinder is too low. Add brake fluid and check for leaks. The reservoir is under the brake pedal and floor plate. See **Figure 27** and **Figure 28**. Clean the area around the fill cap so that no dirt enters the reservoir.

Check the operation of the service brakes. Push on the brake pedal. The brakes must be applied before the pedal reaches the floor plate. The brake pedal must stop firmly and must not move slowly down after the brakes are

applied. The brakes must apply equally to both drive wheels with no noticeable pull to either side.

Automatic Parking Brake

There is an indicator icon on the display panel for the Automatic Parking Brake (APB). The icon is illuminated as described in the **Model Description** section of this manual. If the APB is not applied and the operator leaves the seat or turns the key or keyless switch to the **OFF** position, an alarm will sound for approximately 60 seconds. This is only on manually applied parking brakes, not the Seat Activated parking brake option. **ALWAYS** apply the parking brake when leaving the seat.

Make sure the service brakes operate correctly before checking the operation of the Automatic Parking Brake. Check the operation of the APB. The Automatic Parking Brake, when in good condition and correctly adjusted, will hold a lift truck with a capacity load on a 15% grade [a slope that increases 1.5 m in 10 m (1.5 ft in 10 ft)]. If parking brake requires adjustment, notify service personnel.

Operator Presence System

Check the operation of the Operator Presence System (OPS). Turn the lift truck power **ON** while sitting in the seat.



Maintenance

HYSTER

Once lift truck power is **ON**, get up off the seat. If the OPS is working correctly, a switch in the operator's seat will automatically disable all hydraulic and electrical functions so that the lift truck cannot travel forward or backward when the operator is not on the seat. If the lift truck can travel forward or backward, or the hydraulic functions operate, when the operator is not on the seat, the OPS system is not working properly. See the section **Electrical System** 2200 SRM 1337 to repair or replace the seat switch that makes up the OPS system. See **Operating Procedures** section for more information on how the OPS works.

This lift truck may be equipped with an optional operator presence system which will not allow the truck to travel unless the seat belt is fastened. When equipped, a seat belt interlock includes sequencing/logic for the seat pressure switch and seat belt switch. The weight of the operator must be detected prior to the seat belt switch being engaged to enable operations.

Oil Leaks

Visually check the hydraulic system, steering system, brake system, and transaxle for leaks.

How to Charge the Battery

WARNING

The acid in the electrolyte can cause injury. If electrolyte is spilled, use water to flush the area. Make the acid neutral with a solution of sodium bicarbonate (soda) and water. Acid in the eyes must be immediately flushed with water.

Batteries generate explosive fumes when they are being charged. Keep fire, sparks, and burning material away from the battery charger area. Prevent sparks from the battery connectors.

Charge batteries only in the special area for charging batteries. When charging the batteries, keep the vent caps clean. The battery charger area must have ventilation so that explosive fumes are removed. Open the hood over the battery or remove the cover if the battery has a cover.

Disconnect the battery when doing cleaning and maintenance.



HYSTER

Maintenance

CAUTION

Never connect the battery charger plug to the plug of the lift truck. You can damage the traction control circuit. Make sure the charger voltage is the correct voltage for the battery.

Use only battery chargers approved by the battery manufacturer or dealer.

CAUTION

Always make sure the color in the window of the charger connector is the same as the color in the window of the battery connector.

NOTE: This series of trucks can have one of two types of batteries. One type has removable cell caps. A green key for battery voltage shows in the window of the battery connector for batteries with cell caps. The other type has sealed cells and the electrolyte cannot be checked. A gray key for battery voltage shows in the window of the battery connector for sealed batteries. These sealed batteries also require a different charger.

NOTE: Many installations have battery chargers that can follow a program to automatically charge a battery according to recommendations of the battery manufacturer. Use

the recommendations of the battery manufacturer for charging the battery.

Correct use of the hydrometer and proper operation of the battery charger is important. See **Figure 49**. Follow the instructions of the charger manufacturer. Never let the battery discharge below the minimum value given by the battery manufacturer. A fully charged battery will have a specific gravity of 1.265 to 1.310 at 25 °C (77 °F). See **Figure 49**. Never charge a battery at a rate that will raise the electrolyte temperature above 49 °C (120 °F). Never let a battery stay discharged for long periods.

Normal Charge: This charge is normally given to a battery that is discharged from normal operation. Many customers charge the battery at regular intervals that depend on use. This procedure will keep the battery correctly charged if the battery is not discharged below the limit. Always use a hydrometer to check the battery if the battery is charged at regular intervals and has cell caps. Frequent charging of a battery that has a 2/3 or more charge can decrease the life of the battery.

NOTE: Some batteries are maintenance free and do not require checking the electrolyte. DO NOT attempt to check electrolyte in batteries with sealed cells.



Maintenance

HYSTER

Equalizing Charge: This charge is at a low rate and balances the charge in all of the cells. The equalizing charge is normally given approximately once a month. It is a charge at a slow rate for three to six hours in addition to the regular charging cycle. Do not give an equalizing charge more than once a week. The most accurate specific gravity measurements for a charged battery will be after an equalizing charge. If the specific gravity difference is more than 0.020 between cells of the battery after an equalizing charge, there can be a defective cell. Consult your battery dealer.

Also see the service manual **Industrial Battery**, 2240 SRM 1, for additional information on the charging and maintenance of a battery.

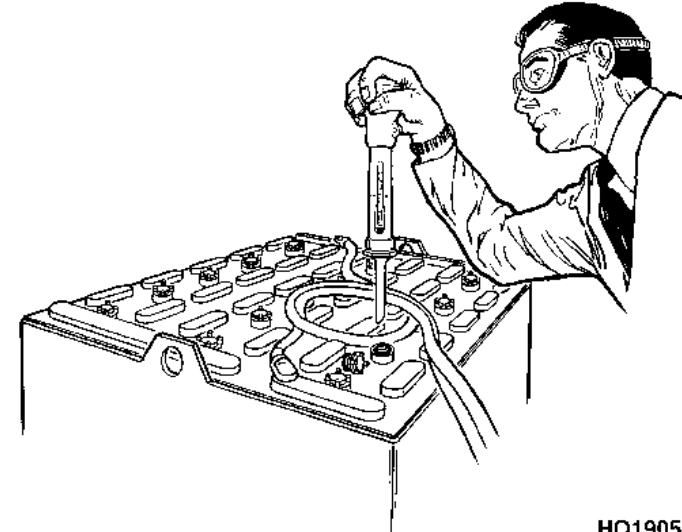

HO190516

Specific Gravity Reading	Electrolyte Temp.	Correction Points	Correct Value
1.210	31 °C (87 °F)	+0.003	1.213
1.210	27 °C (80 °F)	+0.001	1.211
1.210	25 °C (77 °F)	0.000	1.210
1.210	18 °C (64 °F)	-0.004	1.206

+0.001 or -0.001 for each 2 degrees C from the 25-degree base value.

Figure 49. Check Specific Gravity

HYSTER

Maintenance

Rapid Charge

On lift trucks equipped with the Rapid Charge System, the battery is charged during operator breaks or when the truck is not being used. The Rapid Charge System provides extended operation with a single battery. Connect or disconnect battery from Rapid Charge System using connector shown in **Figure 50**.

Features of the Rapid Charge System include:

- Battery connector externally mounted for easy access.
- Vented side covers for improved battery cooling.
- Requires rapid charge vented battery and sealed battery fan box with thermostat.

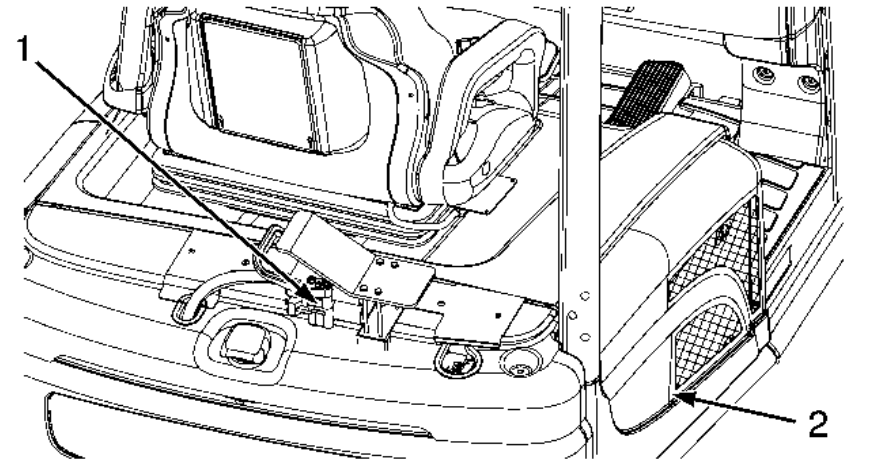

BO190920

1. RAPID CHARGE
CONNECTOR

2. VENTED SIDE COVER

Figure 50. Rapid Charge System



Maintenance

HYSTER

How to Change Batteries

General

WARNING

Batteries are heavy and can cause an injury. Use care to avoid injury. A single trained operator should perform the battery exchange, while other personnel remain clear. **DO NOT** put hands, arms, feet, or legs between the battery and solid objects.

Make sure the capacity of the crane and spreader bar is greater than the weight of the battery. The weight of the battery is normally shown on the battery case. The maximum battery weight is shown on the lift truck Nameplate. The spreader bar must **NOT** be made of metal or it must have insulated straps.

The replacement battery must fit the battery area correctly. Adjust the front spacer plate to prevent battery movement in the battery compartment. Make sure that the battery voltage and weight of the replacement battery is correct as shown on the Nameplate.

Before connecting the battery, make sure the key or keyless switch is in the OFF position and the parking brake is set.

CAUTION

Batteries must be discarded or recycled according to local environmental regulations.

Remove the Battery

1. Use the tilt memory lever and tilt the steering column all the way up. Make sure it is latched.
2. If lift truck is equipped with manual hydraulic control levers, release the latch for the control lever assembly and move the assembly to the forward position. On lift trucks equipped with E-Hydraulic control mini-levers, move the armrest all the way back if necessary to raise the hood. See **Table 1**.
3. Slide the seat all the way back. For lift trucks equipped with Rapid/Fast Charging, slide the seat all the way forward. Push the latch handle to the right to raise the hood and seat to fully raised position.

HYSTER

Maintenance

4. Disconnect the battery connector and move it to a position where it will not be damaged during battery removal. Lift the side panels to remove them.
5. Use a spreader bar and crane to lift the battery from the lift truck. See **Figure 51**.

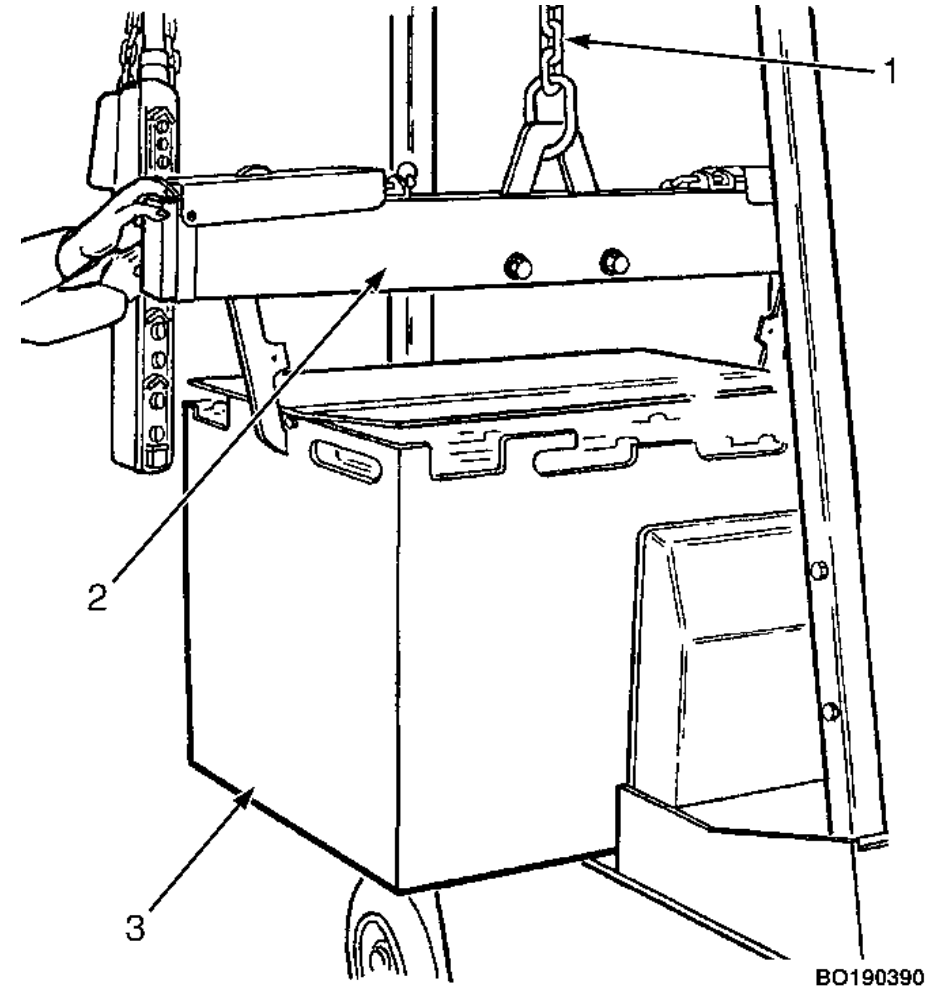

Figure 51. Change the Battery



Maintenance

HYSTER

Legend for Figure 51

1. LIFTING CHAIN
2. SPREADER BAR
3. BATTERY

Install the Battery

WARNING

Correct operation of the battery restraint system requires that the battery does not move more than 13 mm (0.50 in.). Make sure the battery spacer plate is correctly adjusted. Serious injury or property damage can occur if battery spacer plate is not adjusted correctly.

1. When a replacement battery is installed, make sure the battery fits the battery compartment width with a maximum of 13 mm (0.50 in.) clearance. Use a spreader bar and crane and install battery into lift truck. See **Figure 51**.

NOTE: Lift trucks with a 750mm battery compartment may be equipped with a spacer block. See **Figure 52**.

2. The lift trucks are equipped with adjustable spacers in the battery compartment. Add or remove shims from under the front spacer bar to control the movement of the battery. The battery must not move more than a total of 13 mm (0.50 in.) forward or backward. See **Figure 53**.

3. Connect the battery connector. Install the side panels.

4. Close the hood. On lift trucks manufactured through February, 2015 pull latch handle to lock the hood. On lift trucks manufactured after February, 2015 lower the hood until the latch clicks. Slide seat to desired position.

5. If lift truck is equipped with E-Hydraulic mini-levers, adjust the armrest if it was moved prior to raising the hood. If lift truck is equipped with manual hydraulic control levers, pull release lever out and move the control lever assembly into position over the hood. Release the release lever to lock the control lever assembly into place.

HYSTER

Maintenance

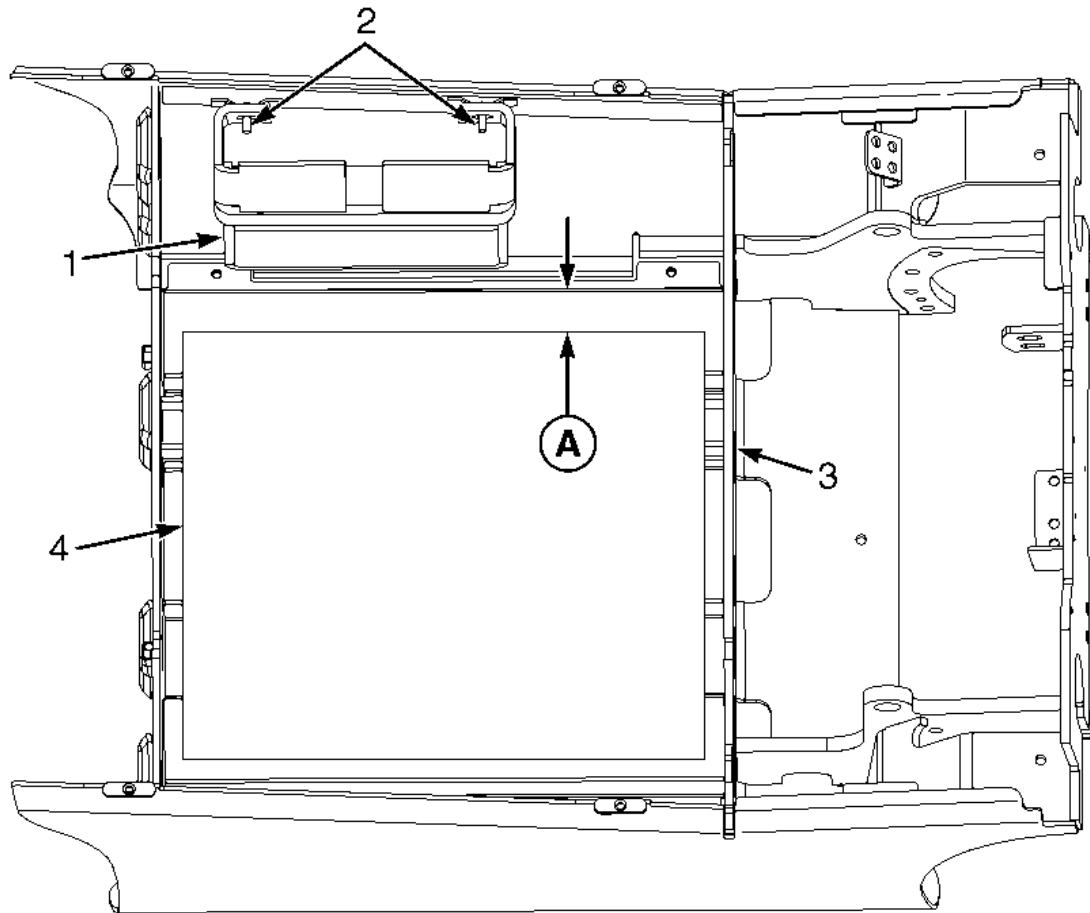

- A. 13 MM (0.50 IN.) MAXIMUM
- 1. SPACER BLOCK
- 2. ADJUSTMENT CAPSCREW
- 3. FRONT BULKHEAD
- 4. BATTERY

BO190509

Figure 52. Battery Compartment Adjustment, Lift Trucks with 750mm Battery Compartment

Maintenance

HYSTER

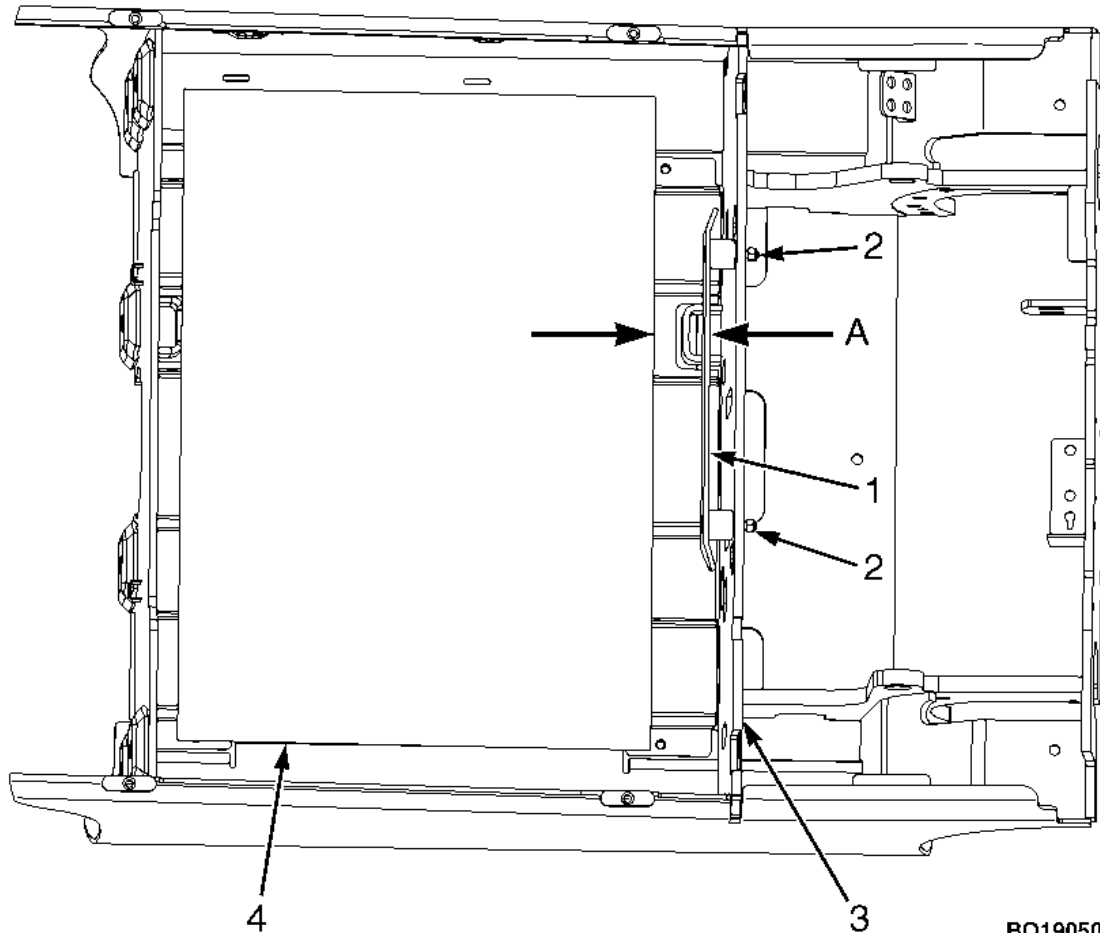

A. 13 MM (0.50 IN.) MAXIMUM

1. FRONT SPACER PLATE
2. ADJUSTMENT CAPSCREW
3. FRONT BULKHEAD
4. BATTERY

BO190508

Figure 53. Battery Compartment Adjustment, Lift Trucks with Front Spacer Plate



HYSTER

Maintenance

Optional Side Removal of Battery - Lift Trucks Manufactured Before March, 2015

WARNING

Batteries are heavy and can cause an injury. Always use a battery roller stand or tray when trucks are equipped with optional battery rollers or slide. Use extreme care to protect hands and other body parts from serious injury while removing and installing battery.

Lift trucks can be equipped for optional side battery removal. See **Figure 54**. This option consists of a battery removal door on the right side of the lift truck and a roller or slider tray beneath the battery. To remove the battery, reach through the slot in the right side floor plate, grasp the

vertical bar, and slide the mechanism toward the front of the truck. The mechanism will lock in place. Position a suitable battery stand or roller tray next to the battery compartment. Be sure that the height of the battery stand is the same as the height of the bottom of the battery in the lift truck. Remove the battery from the lift truck onto the battery stand.

To install the battery, position the battery and battery stand next to the lift truck. Slide the battery from the battery stand into the battery compartment using the roller tray.

Make sure the battery fits the battery compartment width with a maximum of 13 mm (0.50 in.) clearance. Secure the battery retention mechanism and install the battery removal door.

Maintenance

HYSTER

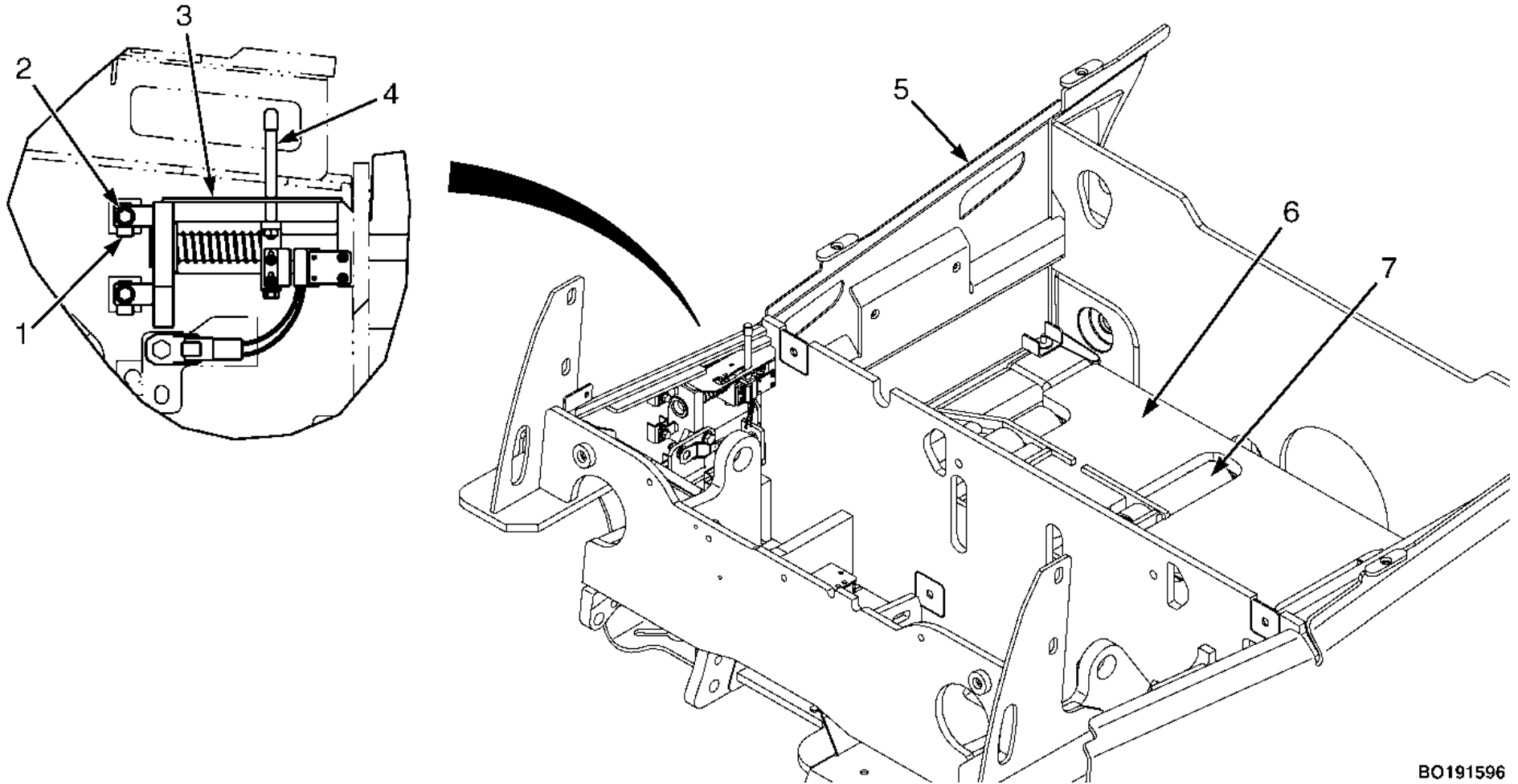

BO191596

Figure 54. Optional Side Removal of Battery - Lift Trucks Manufactured Before March, 2015



HYSTER

Maintenance

Legend for Figure 54

- | | |
|--|---|
| <ol style="list-style-type: none"> 1. RETAINER ASSEMBLY 2. FOLD-OVER NUT 3. CAPSCREW 4. VERTICAL BAR | <ol style="list-style-type: none"> 5. BATTERY REMOVAL DOOR 6. ROLLER TRAY 7. ROLLER ASSEMBLY |
|--|---|

Optional Side Removal of Battery - Lift Trucks Manufactured After February, 2015

WARNING

Batteries are heavy and can cause an injury. Always use a battery roller stand or tray if lift truck is equipped with optional battery rollers or slider. Use extreme care to protect hands and other body parts from serious injury while removing and installing battery.

Lift trucks can be equipped with an optional side battery removal frame. This option consists of a 180-degree hinged battery removal door on the right side of lift truck and one of three options listed below:

- A removable battery tray/stand that is removed from the truck with another lift truck. See **Figure 55** and **Figure 56**. The battery rests on this tray/stand at all times, including when it is outside the lift truck.

- A battery that is removed from the lift truck with a Battery Exchange Stacker. See **Figure 57**. The battery is placed on an external stand for charging.
- A side roller extraction using a slider tray with rollers beneath the battery to roll or slide it off lift truck. See **Figure 58**. The slider tray remains in the lift truck at all times.

To remove the battery, pull latch handle to the right to disengage door from frame. See **Figure 59**. Swing the door assembly all the way to right side, 180 degrees. Door will lock in place to prevent it from moving during removal of the battery. Reach through the slot in the right side floor plate, grasp the vertical bar, and slide the mechanism toward the front of the truck. The mechanism will lock in place.

Maintenance

HYSTER

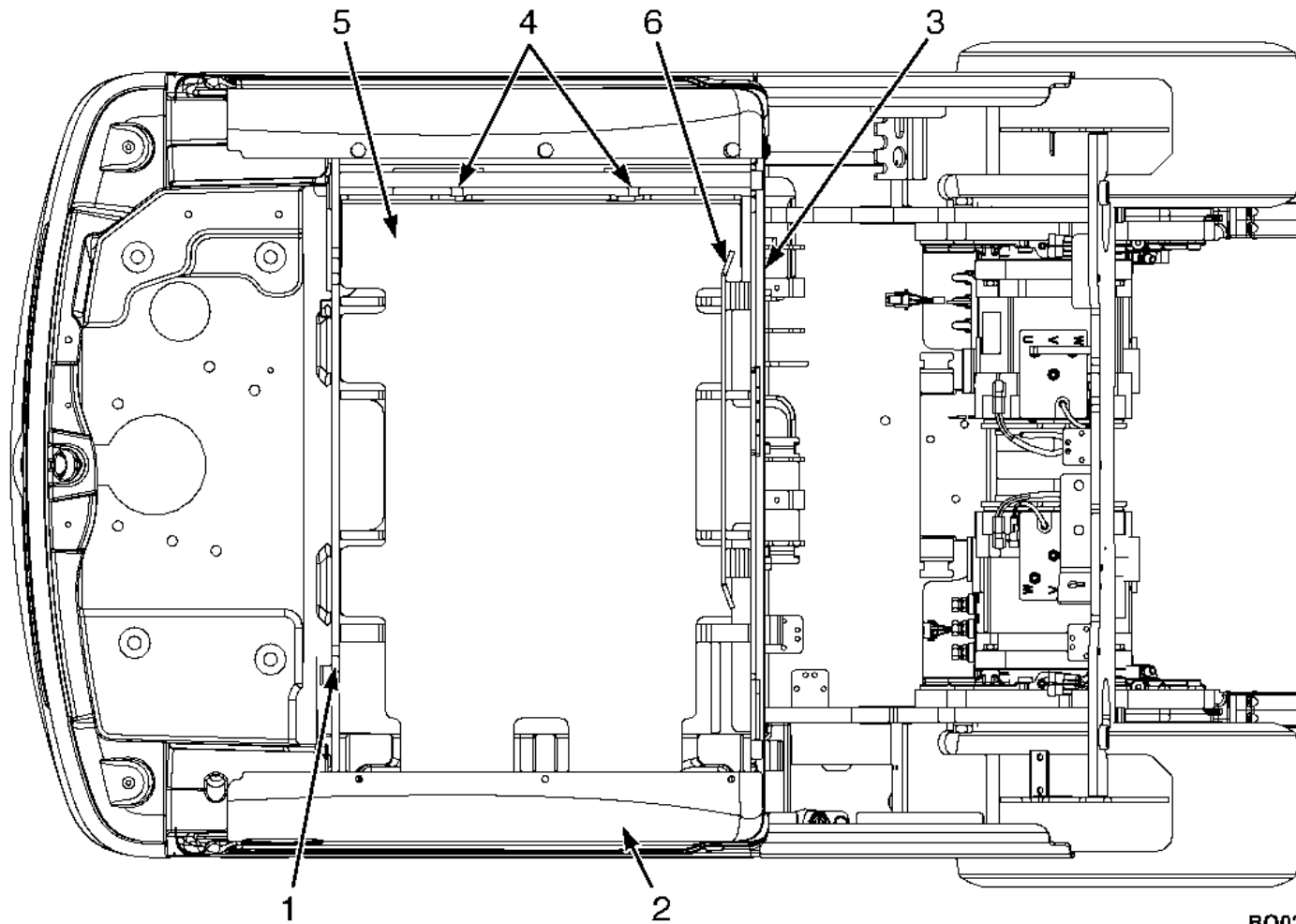

1. REAR PLATE
2. 180-DEGREE HINGED BATTERY REMOVAL DOOR
3. FRONT BULKHEAD
4. BATTERY SPACER
5. REMOVABLE BATTERY TRAY/STAND
6. FRONT SPACER PLATE

BO030008

Figure 55. Optional Removable Battery Tray/Stand (Tray in Place)

HYSTER

Maintenance

1. HOSE COVER
2. CAPSCREW

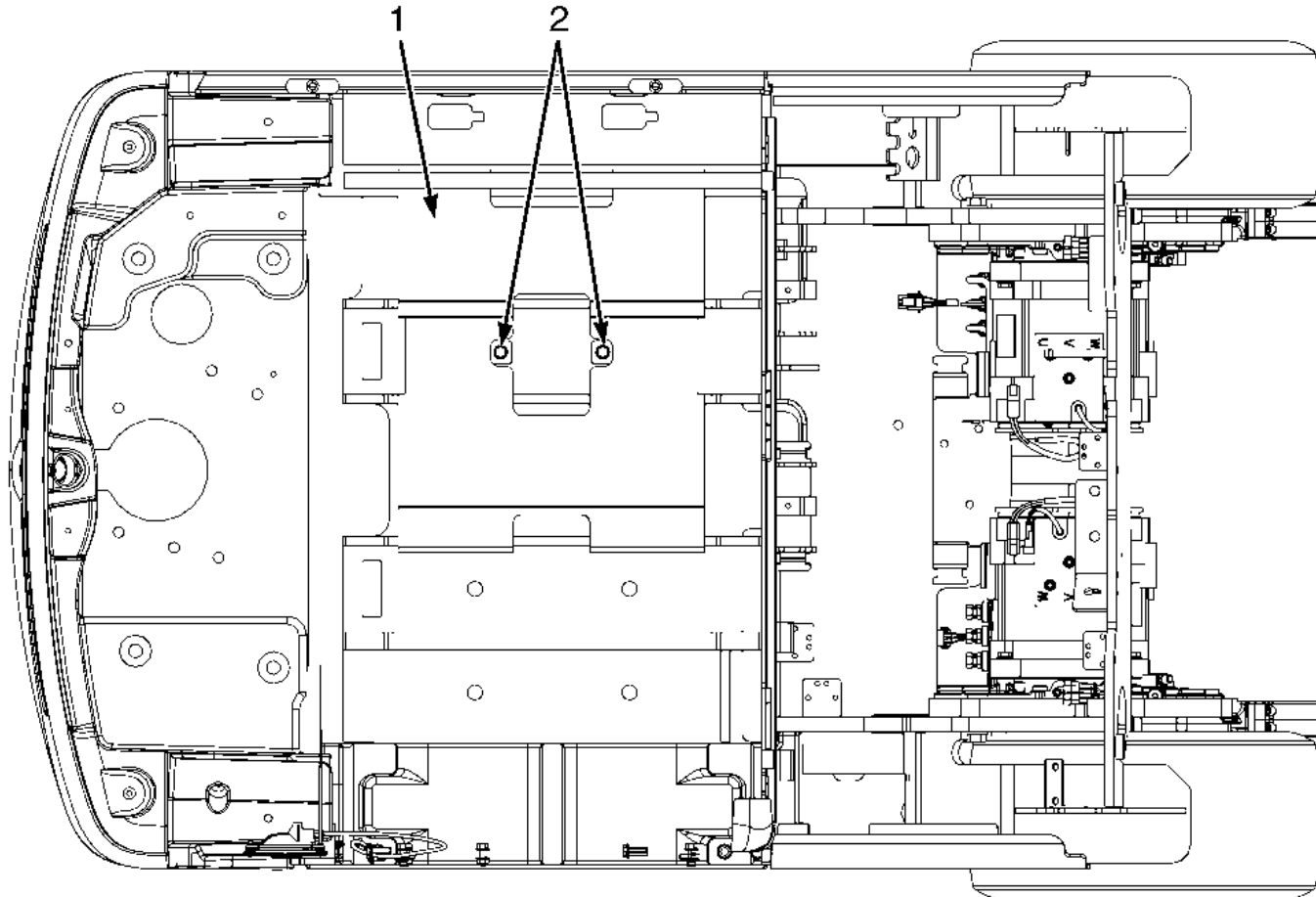

BO030009

Figure 56. Hose Cover, Optional Removable Battery Tray/Stand (Tray Removed)

Maintenance

HYSTER

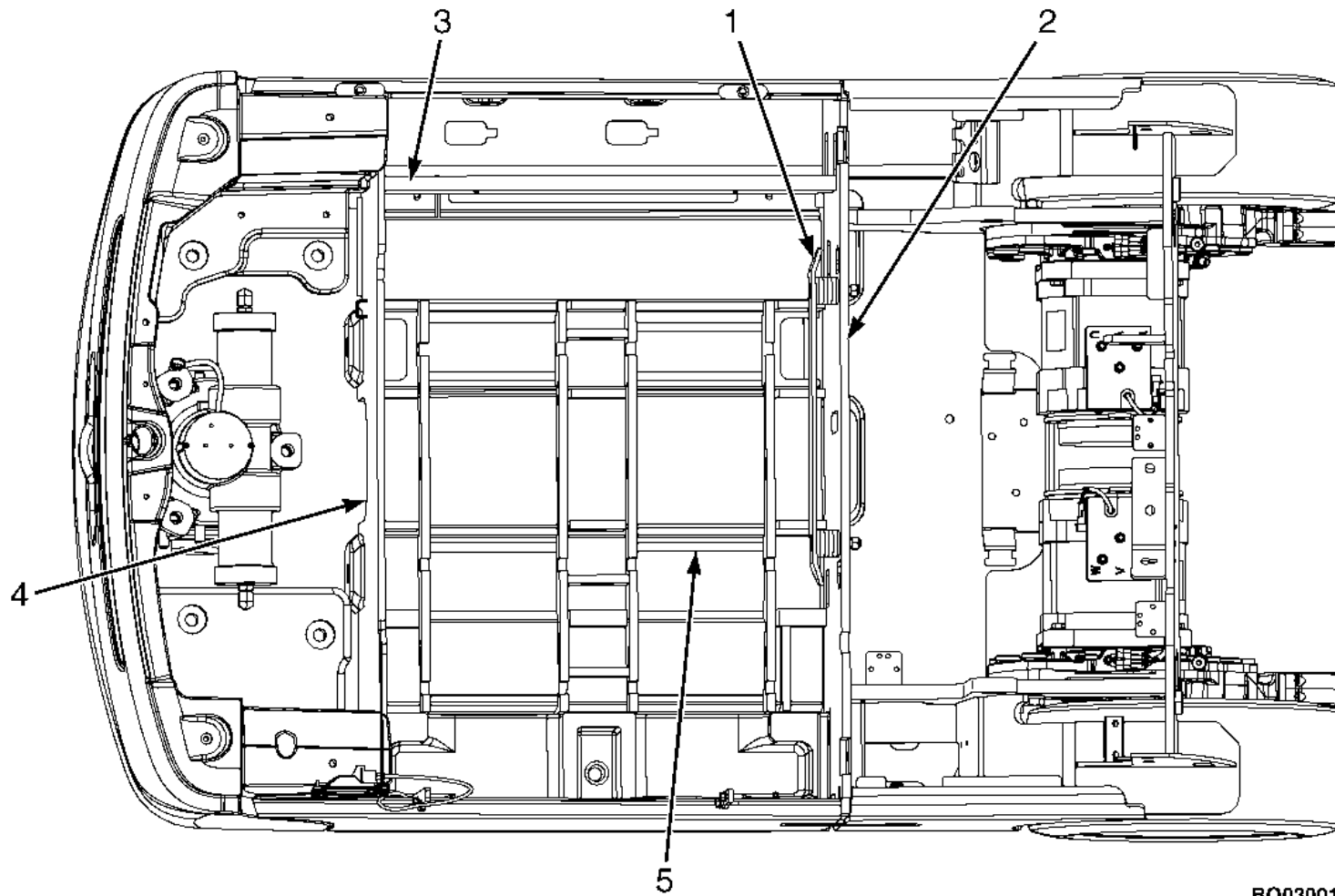

1. FRONT SPACER PLATE
2. FRONT BULKHEAD
3. BATTERY RESTRAINT BAR
4. REAR BULKHEAD
5. BASE PLATE

B0030016

Figure 57. Battery Compartment Used With Optional Battery Exchange Stacker

HYSTER

Maintenance

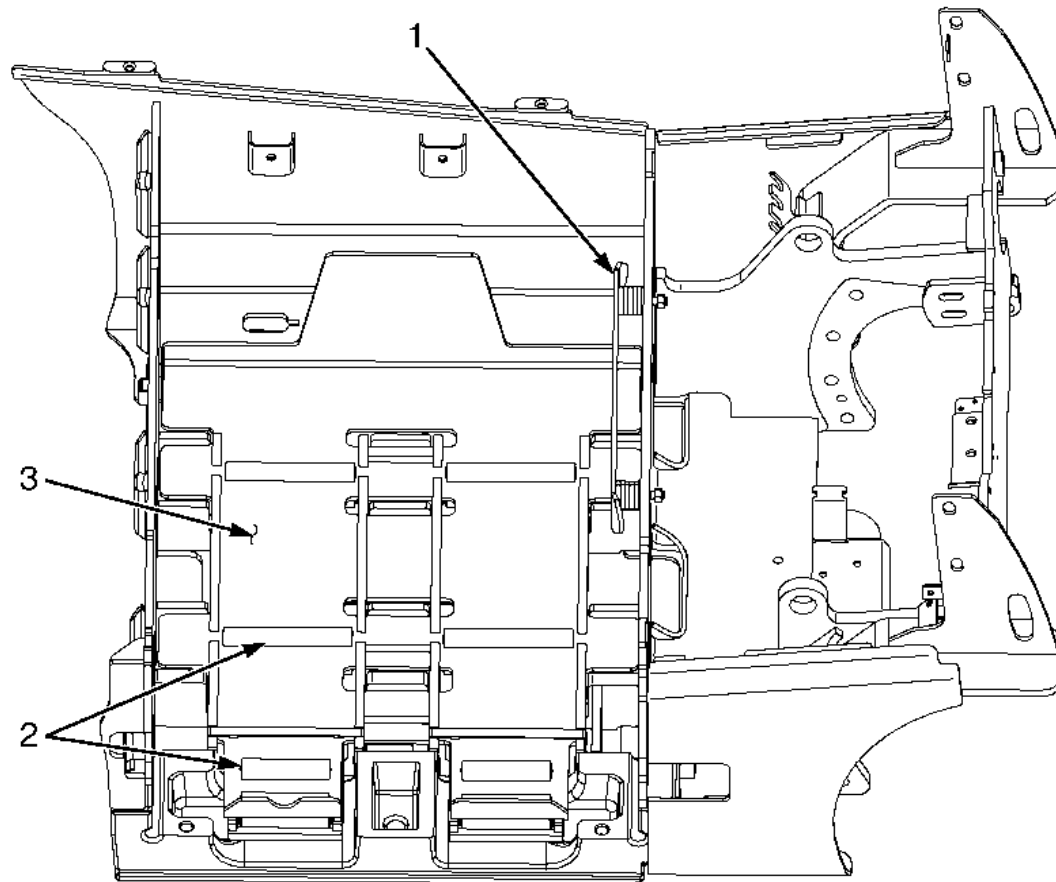

1. FRONT SPACER PLATE
2. ROLLER
3. SLIDER TRAY

BO191136

Figure 58. Battery Compartment with Rollers and Slider Tray

Maintenance

HYSTER

1. 180-DEGREE HINGED BATTERY REMOVAL DOOR
2. LATCH
3. HINGE
4. BRACKET
5. LEVER BAR

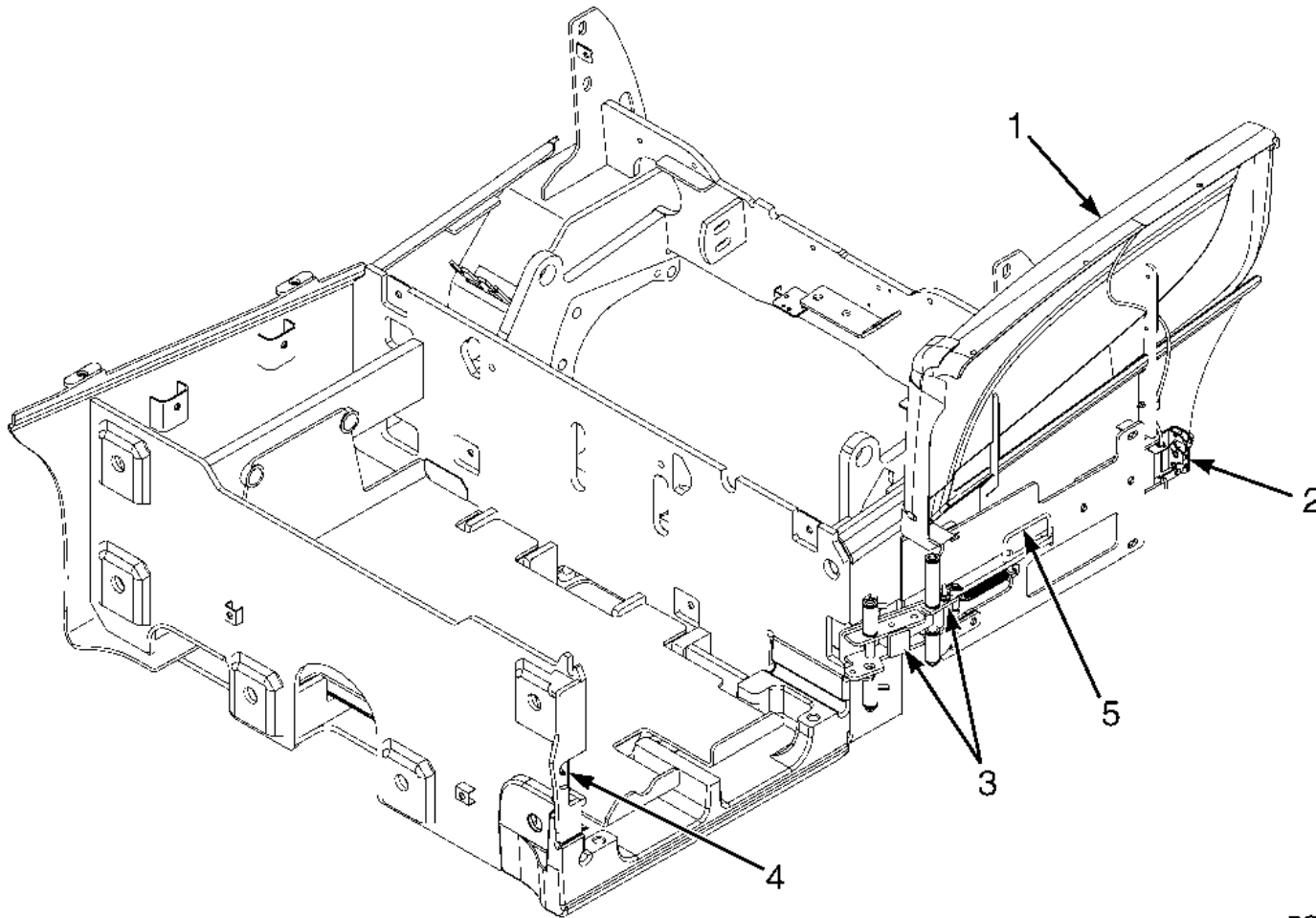

BO120003

Figure 59. 180-Degree Hinged Battery Removal Door Assembly, Lift Truck with Optional Battery Side Removal Compartment

HYSTER

Maintenance

Optional Removable Battery Tray/Stand, Battery Remove

WARNING

To avoid injury and to prevent damage to battery and lift truck, be sure that any lift truck used to remove the battery from another lift truck has enough lifting capacity to safely remove the battery. See the Nameplate for lifting capacity.

Disconnect the battery connector and move it to a position so that it will not be damaged during battery removal. Using another lift truck remove the battery; see below for removal procedure.

NOTE: Forks shown for lift truck removing and transporting the battery.

1. Ensure forks are spaced to insert into fork pockets in removable battery tray/stand. See **Figure 60**.

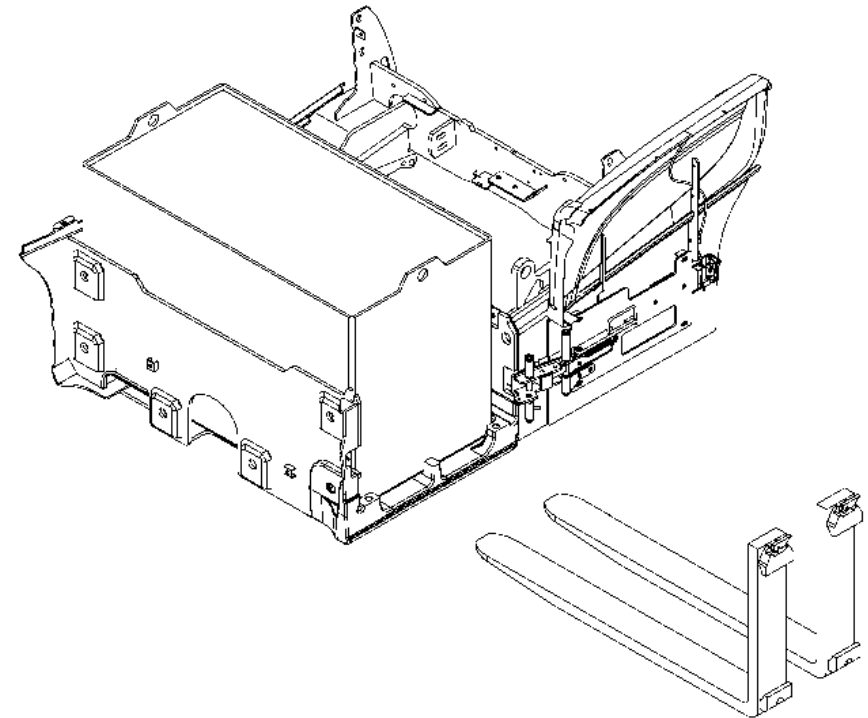

BO030010

Figure 60. Fork Placement

2. If forks are longer than 1000 mm (39.4 in.), remove the fork stop (item 1, **Figure 61**) following steps below:
 - a. Remove battery tray/stand from lift truck frame.
 - b. Turn battery tray/stand upside down.

Maintenance

HYSTER

- c. Remove two nuts, two capscrews, and fork stop from battery tray/stand.
- d. Install battery tray/stand into lift truck frame.

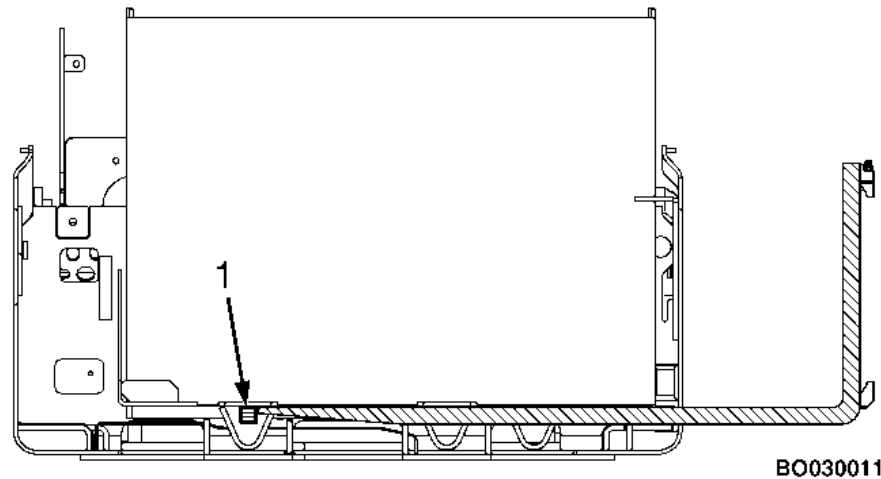

1. FORK STOP

Figure 61. Fork Stop and Inserting Forks

3. Insert forks until the end rests against the fork stop. See **Figure 61**.
4. Raise forks approximately 100 mm (3.94 in.) to clear the frame. See **Figure 62**.

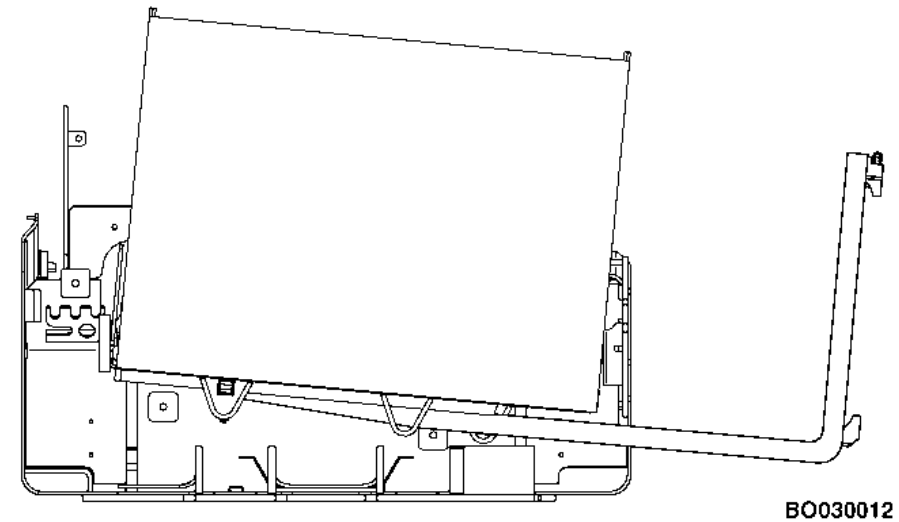

Figure 62. Raise Forks

5. Reverse out of the truck until battery tray/stand is clear of the truck. See **Figure 63**.

HYSTER

Maintenance

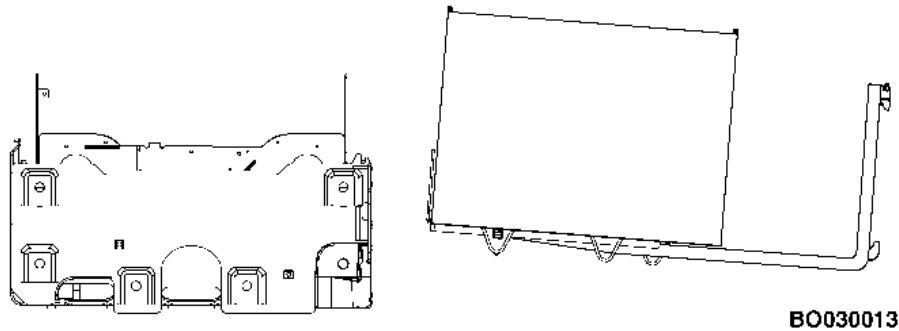
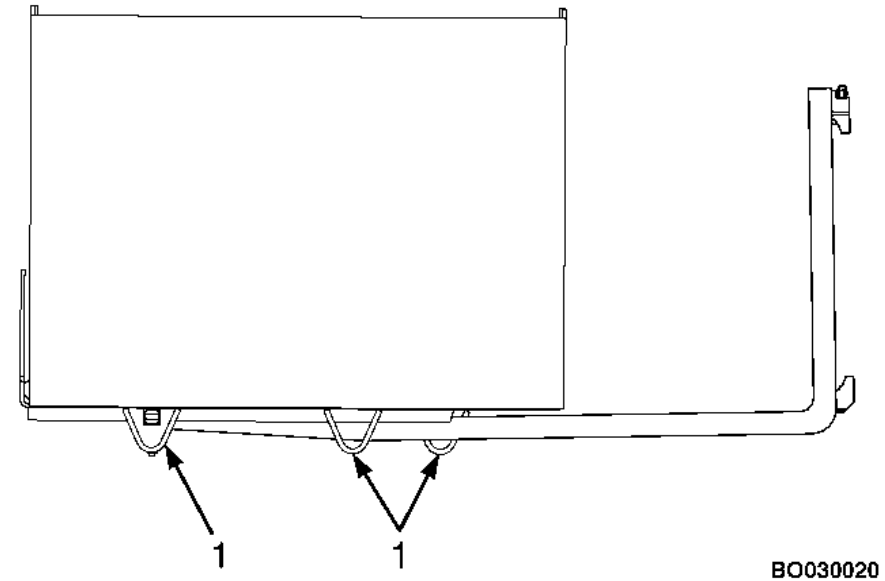

Figure 63. Reverse Out of Truck

6. Lower battery tray/stand so the support plates are on the ground. See **Figure 64**.



1. SUPPORT PLATE

Figure 64. Lowering Battery

7. Lower forks and pull forward until the battery is positioned against the face of the forks. See **Figure 65**. Then lift and transport battery tray/stand to charging area.

Maintenance

HYSTER

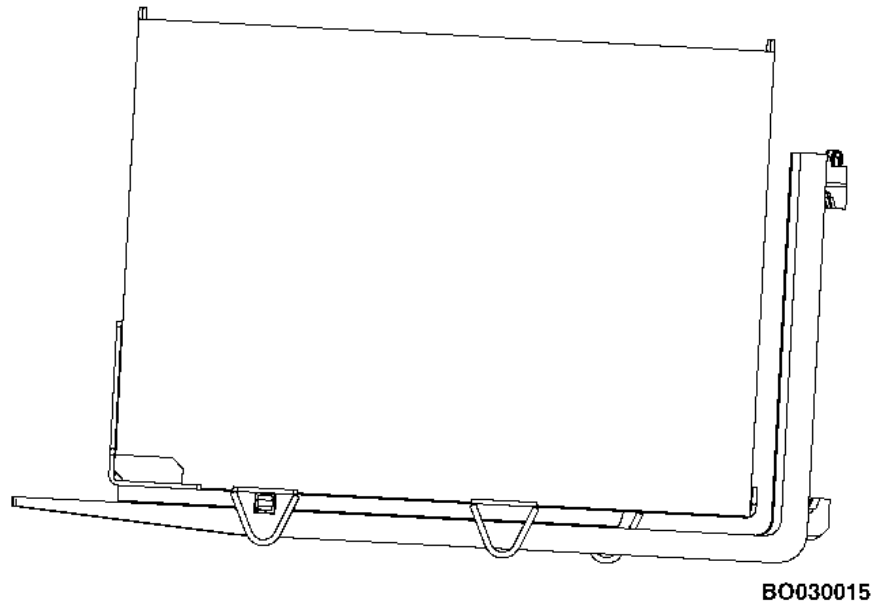

Figure 65. Transport Battery

Optional Removable Battery Tray/Stand, Battery Install

If lift truck is equipped with optional removable battery tray, use another lift truck to install the battery. See below for installation procedures.

1. Lower forks and pull forward until the battery is positioned against the face of the forks. Then lift and transport battery tray/stand to lift truck waiting for battery. Lower the battery tray/stand to the floor. See **Figure 65**.

2. Reverse the truck, raise the forks, and then move forward until forks contact the fork stop. There will be a gap between the battery and the face of the forks. See **Figure 64**.

3. Raise forks approximately 100 mm (3.94 in.) higher than the frame. See **Figure 63**.

4. Insert battery tray/stand into lift truck battery compartment until it hits the frame stop. See **Figure 62**.

5. Lower the forks and reverse out of the lift truck.

If required, after battery is installed into battery compartment, add or remove shims on the battery spacer to control battery movement. The battery is not to move more than a total of 13 mm (0.50 in.) forward or backward. See **Figure 55**.

Connect the battery connector, secure the battery retention mechanism. Close the 180-degree hinged battery removal door. To unlock the door lift red bar, then swing door to the left, and lock latch to striker. See **Figure 59**.

Battery Exchange Stacker Option

The Battery Exchange Stacker is a special tool for removing and installing batteries.



HYSTER

Maintenance

NOTE: Before operating Stacker, read and understand the Stacker Operating Manual. Truck configurations making use of the S2.4HBE (B440) require the battery to sit in a battery tray. The battery and tray are installed to and removed from the truck as one.

To remove battery from lift truck:

- a. Open 180-degree hinged battery removal door. See **Figure 59**.
- b. Reach through slot in the right side floor plate, grasp vertical bar, and slide mechanism toward the front of the truck. The mechanism will lock in place.
- c. Disconnect the battery connector and move it to a position where it will not be damaged during battery remove/install.
- d. Raise the forks enough to enter the battery compartment. Ensure forks of stacker are spaced to insert into fork pockets. See **Figure 60**.
- e. Steer stacker forward until forks can enter lift truck battery compartment. Make sure forks are centered in battery compartment.

- f. Move forks forward until the fork end meets the fork stop. See **Figure 61**.

NOTE: See Stacker Operating Manual for fork face adjustments.

- g. Raise forks and battery (in its tray, if so equipped) then back out of battery compartment. Make sure battery is against fork face.
- h. Using stacker, transport battery (in its tray, if equipped) to charging/storage area.
- i. Place battery (in its tray, if equipped) on battery stand. See **Figure 66**.
- j. Remove forks, leaving battery (in its tray, if equipped) on the stand.

Maintenance

HYSTER

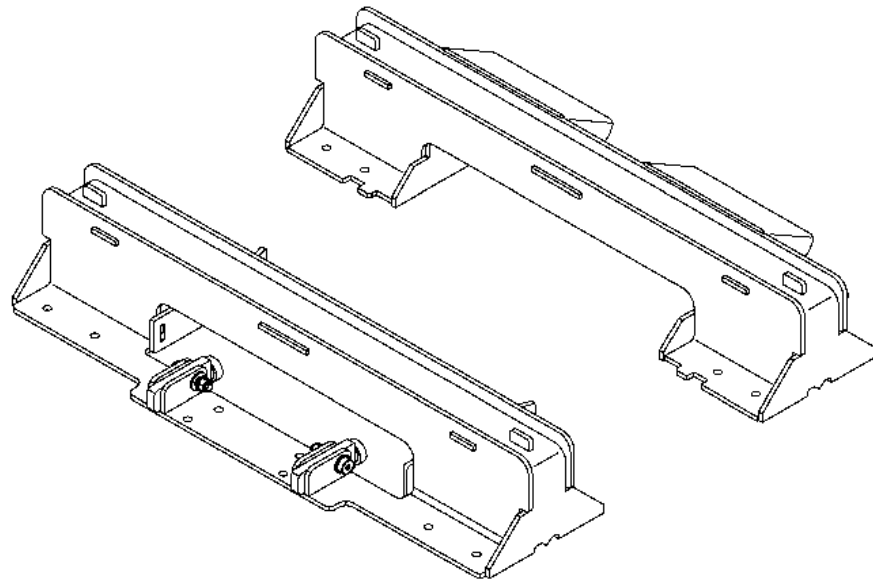

BO210163

Figure 66. Battery Stand

To install a battery in a lift truck:

- a. Position stacker with forks pointing toward battery stand.
- b. Insert forks under battery (in its tray, if equipped) until fork end meets fork stop. See **Figure 61**.

NOTE: See Stacker Operating Manual for fork face adjustments.

- c. Raise battery (in its tray, if equipped) away from battery stand. Make sure battery is against fork face.
- d. Back stacker away from the battery stand; then transport battery (in its tray, if equipped) to lift truck requiring battery installation.
- e. Position stacker with forks facing lift truck battery compartment; make sure forks are centered in compartment.
- f. Raise forks enough to enter battery compartment and move stacker forward, positioning battery (in its tray, if equipped) in lift truck.
- g. Lower battery (in its tray, if equipped) into position and reverse stacker out of compartment.
- h. Connect battery connector.
- i. Reach through slot in the right side floor plate, grasp vertical bar, and slide mechanism toward the rear of the truck. The mechanism will lock in place.
- j. Close 180-degree hinged battery removal door.
- k. Select drive position on tiller handle and move stacker to storage area.

HYSTER

Maintenance

Battery Stand Set-up

The supports need to be placed on the floor in the configuration shown in **Figure 67**. They must be bolted to the floor

for stability. Usage of this system requires two battery stands.

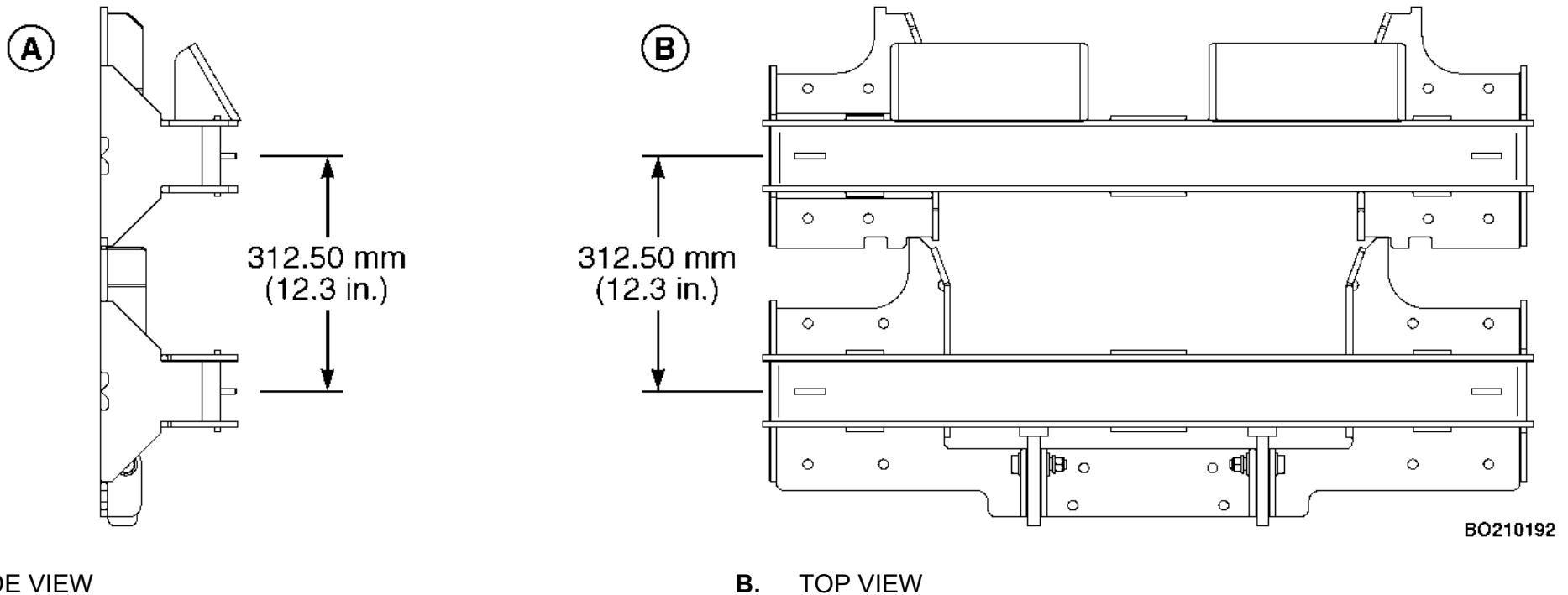

Figure 67. Battery Stand Set-up



Maintenance

HYSTER

Optional Battery Roller Extraction

WARNING

Batteries are heavy and can cause an injury. Always use a battery roller stand or tray when trucks are equipped with optional battery rollers or slider.

Make sure battery roller stand or tray accommodates 180-degree hinged door. The door extends about 250 to 300 mm (9.8 to 11.8 in.) from face of battery.

To remove battery, position battery roller stand next to battery compartment. Be sure that the height of battery roller

stand is the same height as bottom of battery in lift truck. Slide battery from battery compartment onto battery roller stand.

To install battery, position battery and battery roller stand next to lift truck. Slide battery from battery roller stand into battery compartment using rollers.

Make sure battery fits battery compartment width with a maximum of 13 mm (0.50 in.) clearance. Secure the battery retention mechanism, connect the battery connector, and close the door.



HYSTER

Maintenance

Battery Specifications

Table 10. Battery Specifications

Model/ Wheel Base	Min. Compartment Size Length × Width	Maximum Battery Size		Weight		Maximum Battery Compartment Height
		Length	Width	Minimum	Maximum	
J1.5-1.6XNT 1290 mm (50.8 in.)	546 × 991 mm (21.5 × 39 in.)	Standard Battery 537 mm (21.1 in.)	Standard Battery 980 mm (38.6 in.)	Standard Battery 800 kg (1765 lb)	Standard Battery 1100 kg (2425 lb)	Standard Battery 677 mm (26.7 in.)
		DIN Battery 522 mm (20.6 in.)	DIN Battery 830 mm (32.7 in.)	DIN Battery 673 kg (1480 lb)	DIN Battery 743 kg (1640 lb)	DIN Battery 643 mm (25.3 in.)
J1.6-2.0XN6 1385 mm (54.5 in.)	643 × 991 mm (25.3 × 39 in.)	Standard Battery 632 mm (24.9 in.)	Standard Battery 980 mm (38.6 in.)	Standard Battery 1000 kg (2205 lb)	Standard Battery 1200 kg (2646 lb)	Standard Battery 677 mm (26.7 in.)
		DIN Battery 630 mm (24.8 in.)	DIN Battery 830 mm (32.7 in.)	DIN Battery 813 kg (1790 lb)	DIN Battery 899 kg (1980 lb)	DIN Battery 643 mm (25.3 in.)



Maintenance

HYSTER

Table 10. Battery Specifications (Continued)

Model/ Wheel Base	Min. Compartment Size Length × Width	Maximum Battery Size		Weight		Maximum Battery Compartment Height
		Length	Width	Minimum	Maximum	
J1.6-2.0XNT 1495 mm (58.9 in.)	750 × 991 mm (29.5 × 39 in.)	Standard Battery 742 mm (29.2 in.)	Standard Battery 980 mm (38.6 in.)	Standard Battery 1000 kg (2205 lb)	Standard Battery 1300 kg (2865 lb)	Standard Battery 677 mm (26.7 in.)
		DIN Battery 738 mm (29.1 in.)	DIN Battery 830 mm (32.7 in.)	DIN Battery 962 kg (2120 lb)	DIN Battery 1064 kg (2350 lb)	DIN Battery 643 mm (25.3 in.)

The tolerances of the battery compartment are +3 and -0 mm (0.118 and -0 in.). The battery size column shows the size range that will permit the battery to still fit into a battery compartment.

The battery *compartment* length is front to back. Width is side to side. The "length" dimension of the battery must fit within the battery compartment side-to-side dimension with a clearance of 0 to 13 mm (0.50 in.) maximum. Battery width must fit within the battery compartment front-to-back dimension.

 **WARNING**

The battery must fit the battery compartment so that the battery restraint system will operate correctly. Use only batteries with the correct length shown in this table. Adjust the spacer plate and side spacers to prevent the battery from moving more than 13 mm (0.50 in.) forward or backward.



HYSTER

Maintenance

Tires and Wheels

Snap-On Solid Rubber Tires

 **WARNING**

Wheels must be changed and tires repaired by trained personnel only.

Always wear safety glasses.

Lift truck tires and wheels are very heavy. Use caution when removing or installing tires and wheels or personal injury may occur.

1. Put the lift truck on blocks as described in **How to Put a Lift Truck on Blocks** at the beginning of this section.

2. Remove the wheel nuts and remove the wheel and tire from the lift truck. Lift truck tires and wheels are heavy.

NOTE: See **Figure 68** when you disassemble the wheels. There are several types of wheels used on these series of lift trucks.

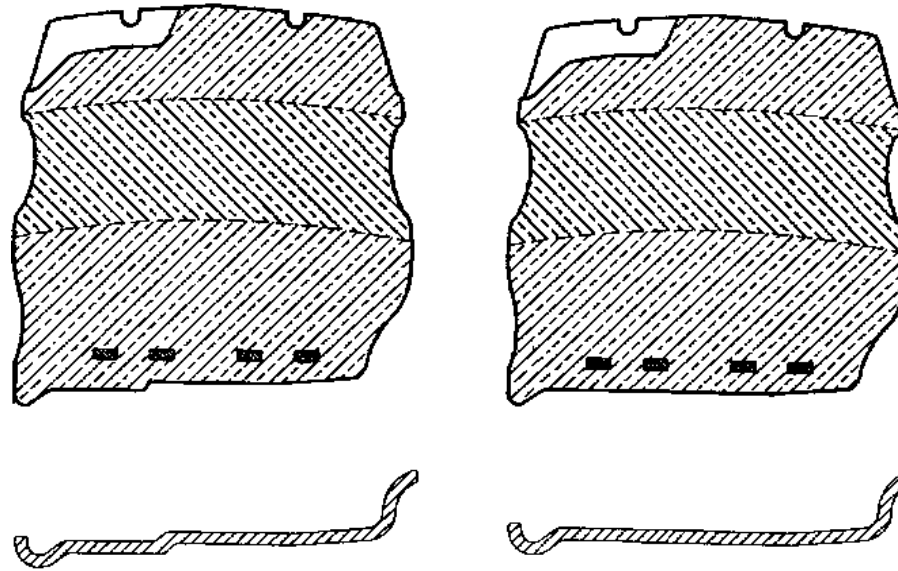

HO210000

Figure 68. Snap-On Tire and Rim Specifications

HYSTER

Maintenance

Remove the Snap-On Solid Tire From the Wheel

WARNING

Keep tire tools in firm contact with the wheel. If the tool slips, it can move with enough force to cause serious injury.

1. Put a support under the wheel rim. Make sure the wheel rim is at least 150 to 200 mm (6 to 8 in.) from the bed of the press.

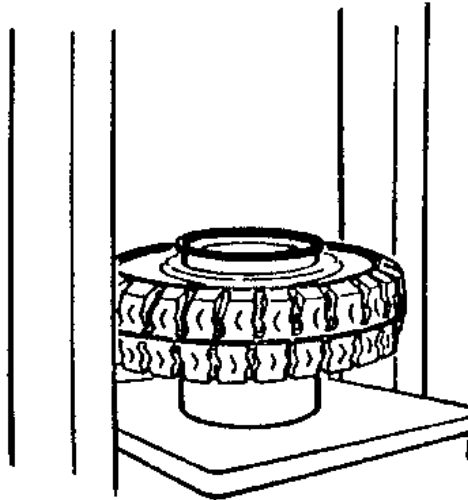

2. Put the cage in position on the tire. Use the press to push the tire from the wheel rim.

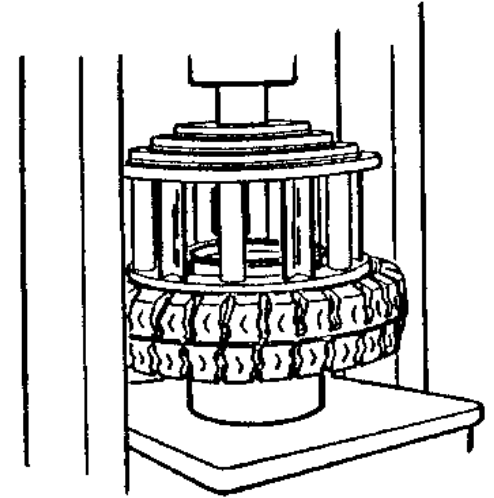

Install the Snap-On Solid Tire on the Wheel

WARNING

Failure to follow these procedures will cause damage to the tire and wheel assembly and can cause injury.

- Clean and inspect all parts of the wheel before installing the tire.
- DO NOT use any damaged or repaired wheel parts.
- Make sure that all parts of the wheel are the correct parts for the wheel assembly.



Maintenance

- DO NOT mix parts between different types or manufacturers of wheels.
- DO NOT mix type of tires, type of tire tread, or wheel assemblies of different manufacturers on any one lift truck.

WARNING

DO NOT use a steel hammer on the wheel. Use a rubber, lead, plastic, or brass hammer to put parts together. Make sure that the side ring is in the correct position. The ends of the side ring must not touch. The clearance at the ends of the lock ring will be approximately 13 to 25 mm (0.5 to 1.0 in.) after it is installed. If the clearance is wrong, the wrong part has been used.

CAUTION

Too much lubricant can cause the tire to slide and move around the wheel rim.

NOTE: When wheels are disassembled, see **Figure 68**. There are several types of wheels used on this series of lift trucks.

HYSTER

WARNING

Keep tire tools in firm contact with the wheel. If the tool slips, it can move with enough force to cause serious injury.

1. Lubricate the wheel rim and the inner surface of the tire with tire lubricant.

2. Put the wheel rim on the bed of the press. Put the tire over the wheel rim. Put the cage in position on the tire. Use the press to install the tire on the wheel rim.

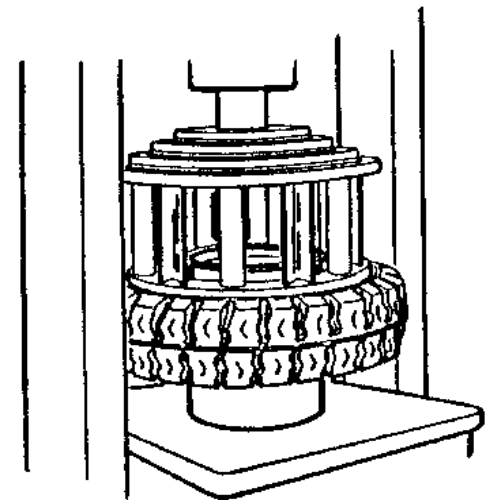
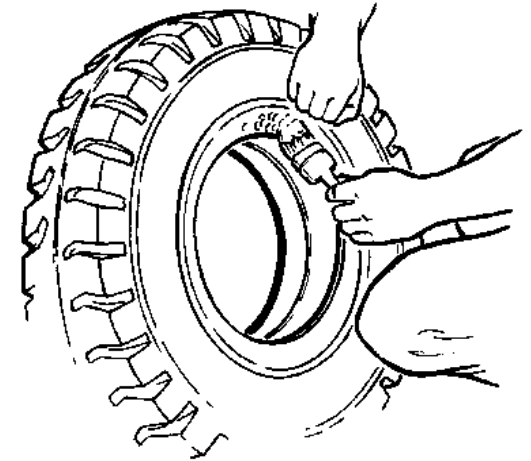



HYSTER

Maintenance

Tire Sizes

Table 11. Tires Sizes

J1.5XNT	Steer Tire Size	Drive Tire Size
Snap-On Solid Pneumatic	15 × 4.5 - 8	18 × 7 - 8
J1.6XNT	Steer Tire Size	Drive Tire Size
Snap-On Solid Pneumatic	15 × 4.5 - 8	18 × 7 - 8
J1.8XNT	Steer Tire Size	Drive Tire Size
Snap-On Solid Pneumatic	15 × 4.5 - 8	18 × 7 - 8
J2.0XNT	Steer Tire Size	Drive Tire Size
Snap-On Solid Pneumatic	15 × 4.5 - 8	*200/50-10
*Required drive tires for lift trucks equipped with mast heights of 5000 mm (196.9 in.) or greater.		

Install Snap-On Solid Tire and Wheel on Lift Truck

WARNING

Lift truck tires and wheels are very heavy. Use caution when removing or installing tires and wheels or personal injury may occur.

1. Install wheel assembly onto lift truck.
2. Install wheel nuts and tighten in a cross pattern to 170 N•m (125 lbf ft).
3. Remove lift truck from blocks.

How to Put an Electric Sit Down Rider Truck in Storage

To prevent problems, the lift truck must be correctly serviced and maintained during storage.

Components that need extra care during storage are electric motors, hydraulic components, and electric truck batteries.

Electric trucks can best be protected by being operated for a short period of time each month.



Maintenance

HYSTER

Before any lift truck is put in storage, you must choose an area which is clean, dry, and free from dust or fumes in the air that can harm the lift truck.

Electric drive motors must be operated to keep them free of rust and dirt caused by condensation over periods when the truck is not used. Operate the truck with the motor at its normal temperature for at least five minutes.

This operating period will also allow the Motor Controller to remove any moisture in the control area.

For safety and increased floor space, it is recommended remove the forks and tag them with the truck serial number.

Before operating a truck each month, make a visual inspection for leaks or signs of wear or damage. Take care of any problems immediately. Also, check the fluid level in the hydraulic tank and brake master cylinder.

Electric trucks must not have batteries installed during storage. A fully-charged battery must be available to operate the lift truck.



CAUTION

Do not use a battery charger as a power source for any reason.

All hydraulic cylinders must be put through a complete operation cycle several times each month. This will help keep the seals active and coat the interior walls with oil. Operate each cylinder, to the stop in both directions.

To protect the tilt cylinder rods, park your truck with the mast tilted fully backward (cylinders fully retracted).

When parked, with the power off, operate each control handle to release hydraulic pressure.

Masts are to be stored fully lowered.

Coat any exposed part of all cylinder rods with SAE 30 or SAE 40 engine oil.

Put blocks at the front and rear of a drive tire when parked - do not use the parking brake.

Put blocks at the front and rear of a drive tire when parked - do not apply the Automatic Parking Brake.



HYSTER

Maintenance

How to Put Batteries in Storage

Batteries are to be placed on a wood pallet and put in storage in a dry, cool area.

Lead acid batteries will slowly 'self-discharge' over a period of time due to their chemical properties. If the self-discharge is not controlled, too much sulfation can occur which is difficult to reduce and can damage the plates. A discharged battery with a specific gravity of 1,100 will freeze at $-7.8\text{ }^{\circ}\text{C}$ ($18\text{ }^{\circ}\text{F}$). A fully-charged battery with a specific gravity of 1.280 will freeze at $-66\text{ }^{\circ}\text{C}$ ($-86.8\text{ }^{\circ}\text{F}$).

This 'self-discharge' is due to chemical action; therefore, that chemical action can be accelerated by heat resulting in a more rapid 'self-discharge.' The rate of discharge can be an average of about 0.001 point drop in specific gravity each day.

The following procedure must be followed when placing a battery in storage or when it is not in operation for more than 30 days.

1. Perform equalizing charge before placing new batteries in storage. Used batteries must be fully charged and allowed to balance for approximately three more hours.

2. Neutralize and clean the battery. Clean with a solution of 500 mL of baking soda in one 4.0 L of water.

3. Put the battery in a cool, dry location for storage.

4. Check each cell in the battery at least once every 30 days and give an additional charge when specific gravity falls below 1.240.

5. Protect batteries from getting dirty.

If a greasy film forms on the top of a battery, it is acid and must be neutralized with the baking soda solution described above.

Battery chargers must be disconnected from the AC power source when not in use.

How to Put a Lift Truck Back Into Service

Electric lift trucks are best protected by being operated for a short period of time each month as stated in the section **How to Put an Electric Sit Down Rider Truck in Storage**. Before returning an electric lift truck to service, perform the following checks:

1. Install battery into lift truck. See the section **How to Change Batteries** in this maintenance section for procedures. If a new battery will be installed, give an equalizing



Maintenance

HYSTER

charge before using. If a used battery will be installed, it must be fully charged and allowed to balance for approximately three hours before using.

2. If the forks were removed, install forks.
3. Operate the truck with the traction motor at its normal temperature for at least five minutes. This will clean any dirt or rust, caused by condensation, from the drive motor.
4. Operate the hydraulic cylinders through a complete operation cycle to coat the interior walls with oil. Operate each cylinder to the stop in both directions.
5. Check all fluid levels.
6. Check condition of tires.

How to Move a Lift Truck on a Transport

Before the lift truck is moved on a transport, check the selected route to make sure there is enough clearance for the lift truck as loaded on the transport vehicle. Bridges, overpasses, powerlines, and natural barriers can prevent clearance. Removal of the mast can be necessary.

If a trailer is the method of transportation, use blocks in front and back of the trailer tires to prevent movement of the trailer when the lift truck is loaded and unloaded. If a

loading ramp is used, make sure that the ramp is the correct design and capacity.

If the lift truck is equipped with lifting eyes, use a crane to load and unload the lift truck from the transport. If the truck is not equipped with approved lifting eyes, do not lift the truck by attaching a lifting device to any other part of the lift truck for the purposes of loading or unloading.

Loading

If components and attachments must be removed for transport of the lift truck, see the **Service Manual** for removal procedures.

The operator must never leave a lift truck in a condition so that it can cause damage and injury. When the lift truck is loaded on the transport, do the following operations:

1. Apply the parking brake.
2. If the mast is mounted on the lift truck, fully lower the forks or carriage. Tilt the mast **FORWARD** until the tips of the forks touch the surface.
3. Turn the key switch to the **OFF** position. Check that all switches and accessories are turned off.



HYSTER

Maintenance

WARNING

The straps or chains used to fasten the lift truck to the transport must be directly connected to the lift truck frame or to a component (drive axle, tow pin) that is solidly attached to the frame. Do not fasten a strap or chain to the mast or any attachment to hold the lift truck on the transport.

CAUTION

Make sure that any straps or chains used to fasten the lift truck to the transport do not contact any tubes, hoses, hydraulic cylinders, or other parts of the truck that are easily damaged.

4. Secure the lift truck tires to the transport vehicle using straps or chains.

5. Put blocks in front and back of the lift truck tires to prevent any movement of the lift truck. Make sure the blocks are attached to the load surface.

If the lift truck is transported in severe weather or any other condition that can damage the lift truck, cover the lift truck. Make sure the protective cover is designed for the application and is securely fastened.

Unloading

If components normally attached to the lift truck were removed for transport, see the **Service Manual** for installation procedures.

1. If used, remove any protective cover.
2. Make sure the parking brake is applied.
3. Disconnect the straps or chains.
4. Remove the wheel blocks.
5. Check that all switches and accessories are turned off.
6. Unload the lift truck.

Preparation for Use

After being transported or stored, the lift truck must be prepared for use for proper operation. All problems must be corrected before use of the lift truck. See the **Service Manual** for procedures.

Preparation After Transport

1. Complete the unloading procedures.



Maintenance

HYSTER

2. Inspect the lift truck for damage and missing components.
3. Follow the steps in the section **How to Make Checks With the Key or Keyless Switch OFF**.

Changes to the Overhead Guard

 **WARNING**

Do not operate the lift truck without the overhead guard correctly fastened to the lift truck.

Do not make changes to the overhead guard by welding or drilling. Changes that are made by welding or by drilling holes that are too big in the wrong location, can reduce the strength of the overhead guard.

See your dealer for Hyster lift trucks BEFORE performing any changes to the overhead guard.



HYSTER

Maintenance

Maintenance Register

Protect your investment in materials handling equipment! Keep a high-residual value in your **Hyster** lift truck! Do the maintenance according to the **Maintenance Schedule** in this **Operating Manual**.

Your dealer for **Hyster** lift trucks has the equipment and trained service personnel to do a complete program of inspection, lubrication, and maintenance.

This **Maintenance Register** is used to record the time of each periodic inspection and maintenance. The dealer's stamp or authorized signature confirms that maintenance and inspection was done at regular intervals by authorized personnel.

1. Operating Hours _____ Date _____	2. Operating Hours _____ Date _____	3. Operating Hours _____ Date _____	4. Operating Hours _____ Date _____
5. Operating Hours _____ Date _____	6. Operating Hours _____ Date _____	7. Operating Hours _____ Date _____	8. Operating Hours _____ Date _____
9. Operating Hours _____ Date _____	10. Operating Hours _____ Date _____	11. Operating Hours _____ Date _____	12. Operating Hours _____ Date _____
13. Operating Hours _____ Date _____	14. Operating Hours _____ Date _____	15. Operating Hours _____ Date _____	16. Operating Hours _____ Date _____



Maintenance

HYSTER

17. Operating Hours _____ Date _____	18. Operating Hours _____ Date _____	19. Operating Hours _____ Date _____	20. Operating Hours _____ Date _____
21. Operating Hours _____ Date _____	22. Operating Hours _____ Date _____	23. Operating Hours _____ Date _____	24. Operating Hours _____ Date _____
25. Operating Hours _____ Date _____	26. Operating Hours _____ Date _____	27. Operating Hours _____ Date _____	28. Operating Hours _____ Date _____
29. Operating Hours _____ Date _____	30. Operating Hours _____ Date _____	31. Operating Hours _____ Date _____	32. Operating Hours _____ Date _____
33. Operating Hours _____ Date _____	34. Operating Hours _____ Date _____	35. Operating Hours _____ Date _____	36. Operating Hours _____ Date _____
37. Operating Hours _____ Date _____	38. Operating Hours _____ Date _____	39. Operating Hours _____ Date _____	40. Operating Hours _____ Date _____
41. Operating Hours _____ Date _____	42. Operating Hours _____ Date _____	43. Operating Hours _____ Date _____	44. Operating Hours _____ Date _____



NO MATTER HOW YOU SAY IT . . .

La Sécurité Ça Se Paye
La Seguridad Compensa
Betriebssicherheit Macht Sich Bezahlt
Passaa Oll Huolellinen
Veiligheid Voor Alles
Säkerhet Först
Essere Sicuro Paga
Seguranca Paga
Sikkerhet Først
Pinter Be Awas

सावधान और जिन्दा रहो ।

في التاني السلامة

安全第一

**SAFETY
PAYS!**



OPERATING MANUAL

J1.5-2.0XNT (K160)

DO NOT REMOVE THIS MANUAL FROM THIS UNIT